



Техноспринт

**Ремонт
сервоусилителей / сервоконтроллеров
Indramat Bosch Rexroth**

Ремонт DKC03.3-016-7-FW



<https://wa.me/78123392525>



<https://technosprint.ru>



ECODRIVE03 Drive Controllers

Project Planning Manual

SYSTEM200

Title	ECODRIVE03 Drive Controllers
Type of Documentation	Project Planning Manual
Document Typecode	DOK-ECODR3-DKC**.3****-PR05-EN-P
Internal File Reference	<ul style="list-style-type: none"> • Box 71 / 72 / 73 • Document Number, e.g. 120-1000-B307-05/EN
Purpose of Documentation	<p>This documentation describes ...</p> <ul style="list-style-type: none"> • planning the mechanical construction • planning the electrical • logistical handling of the equipment • preparing the necessary equipment for startup operation

Record of Revisions

Description	Release Date	Notes
DOK-ECODR3-DKC**.3****-PRJ1-EN-P	04.98	1st edition
DOK-ECODR3-DKC**.3****-PR03-EN-P	09.99	new edition
DOK-ECODR3-DKC**.3****-PR04-EN-P	05.00	revision
DOK-ECODR3-DKC**.3****-PR05-EN-P	02.02	revision

Copyright © 2002 Rexroth Indramat GmbH

Copying this document, giving it to others and the use or communication of the contents thereof without express authority, are forbidden. Offenders are liable for the payment of damages. All rights are reserved in the event of the grant of a patent or the registration of a utility model or design (DIN 34-1).

Validity The specified data is for product description purposes only and may not be deemed to be guaranteed unless expressly confirmed in the contract. All rights are reserved with respect to the content of this documentation and the availability of the product.

Published by Rexroth Indramat GmbH
Bgm.-Dr.-Nebel-Str. 2 • D-97816 Lohr a. Main
Telephone 09352/40-0 • Tx 689421 • Fax 09352/40-4885
<http://www.boschrexroth.de/>
Dept. EDH/EDY1 (RR/US)

Note This document has been printed on chlorine-free bleached paper.

Supplementary documentation

Note: The following documentation is not required in its entirety for project planning.

"Servo Applications with 1,5 s Acceleration Time"

- Selection lists -

DOK-ECODR3-SERV-GEN***-AUxx-MS-P

"Servo Applications with 400 ms Acceleration Time"

- Selection lists -

DOK-ECODR3-SERV-WZM***-AUxx-MS-P

"Main drives with 2AD-, ADF- and 1MB-motors"

- Selection lists -

DOK-ECODR3-MAIN*WZM***-AUxx-MS-P

"List of Connecting Cables for DIAX04 and ECODRIVE03"

- Selection lists -

DOK-CONNEX-CABLE*STAND-AUxx-EN-P

"ECODRIVE03 Drive for Machine Tool Applications With SERCOS-, Analog- and Parallelinterface"

- Functional Description -

DOK-ECODR3-SMT-01VRS**-FKxx-EN-P

"ECODRIVE03 Drive for Machine Tool Applications With SERCOS-, Analog- and Parallelinterface"

- Functional Description -

DOK-ECODR3-SMT-02VRS**-FKxx-EN-P

"ECODRIVE03 Drive for General Automation With SERCOS-, Analog- and Parallelinterface"

- Functional Description -

DOK-ECODR3-SGP-01VRS**-FKxx-EN-P

"ECODRIVE03 Drive for General Automation With Fieldbus-Interfaces"

- Functional Description -

DOK-ECODR3-FGP-01VRS**-FKxx-EN-P

"ECODRIVE03 Drive for General Automation With Fieldbus-Interfaces"

- Functional Description -

DOK-ECODR3-FGP-02VRS**-FKxx-EN-P

"ECODRIVE03 Drive for General Automation With Fieldbus-Interfaces"

- Functional Description -

DOK-ECODR3-FGP-03VRS**-FKxx-EN-P

"LWL - Handling"

- Application Manual -

DOK-CONNEC-CABLE*LWL-AWxx-EN-P

"Electromagnetic Compatibility (EMC) in Drive and Control Systems"

- Project Planning Manual -

DOK-GENERL-EMV*****-PRxx-EN-P

"Digital AC Motors MKD"

- Project Planning Manual -

DOK-MOTOR*-MKD*****-PRxx-EN-P

"Digital AC Motors MHD"

- Project Planning Manual -

DOK-MOTOR*-MHD*****-PRxx-EN-P

"MKE Digital AC Motors for potentially explosive areas"

- Project Planning Manual -

DOK-MOTOR*-MKE*****-PRxx-EN-P

"2AD AC Motor"

- Project Planning Manual -

DOK-MOTOR*-2AD*****-PRxx-EN-P

"ADF Main Spindle Motors"

- Project Planning Manual -

DOK-MOTOR*-ADF*****-PRxx-EN-P

"1MB Frameless Spindle Motor"

- Project Planning Manual -

DOK-MOTOR*-1MB*****-PRxx-EN-P

"Synchronous MBS Kit Spindle Motors"

- Project Planning Manual -

DOK-MOTOR*-MBS*****-PRxx-EN-P

LAR 070-132 Gehäuse-Linearmotoren

- Selection and Project Planning -

DOK-MOTOR*-LAR*****-AWxx-DE-P

"LAF050 – 121 Linear Motors"

- Selection and Project Planning -

DOK-MOTOR*-LAF*****-AWxx-EN-P

"Linear Synchronous Direct Drives LSF"

- Project Planning Manual -

DOK-MOTOR*-LSF*****-PRxx-EN-P

"AC Drive Units in Personnel Conveyor Systems"

- Application Manual -

DOK-GENERL-ANTR*PERSON-ANxx-EN-P

"AC Drive Units in Hazardous Areas (Expl. Protection)"

- Application Manual -

DOK-GENERL-ANTR*EXPLOS-ANxx-EN-P

"ECODRIVE03 Drive for Machine Tool Applications With SERCOS-, Analog- and Parallelinterface"

- Troubleshooting Guide -

DOK-ECODR3-SMT-01VRS**-WAR*-EN-P

"ECODRIVE03 Drive for Machine Tool Applications With SERCOS-, Analog- and Parallelinterface"

- Troubleshooting Guide -

DOK-ECODR3-SMT-02VRS**-WAR*-EN-P

"ECODRIVE03 Drive for General Automation With SERCOS-, Analog- and Parallelinterface"

- Troubleshooting Guide -

DOK-ECODR3-SGP-01VRS**-WAxx-EN-P

"ECODRIVE03 Drive for General Automation With Fieldbus-Interfaces"

- Troubleshooting Guide -

DOK-ECODR3-FGP-01VRS**-WAxx-EN-P

"ECODRIVE03 Drive for General Automation With Fieldbus-Interfaces"

- Troubleshooting Guide -

DOK-ECODR3-FGP-02VRS**-WAxx-EN-P

"ECODRIVE03 Drive for General Automation With Fieldbus-Interfaces"

- Troubleshooting Guide -

DOK-ECODR3-FGP-03VRS**-WAxx-EN-P

"DOLFI, Auxiliary for Download Firmware"

- Application Manual -

DOK-DOLFI DO01D**W

Notes

Contents

1	Introduction to the System	1-1
1.1	Drive package ECODRIVE03	1-1
1.2	An Overview of Individual Components of the ECODRIVE03 Family	1-2
1.3	An Overview of Drive Controllers and Auxiliary Components.....	1-3
	An Overview of Communications Interfaces.....	1-3
	An Overview of Measuring Systems Supported	1-4
	Type Code for Drive Controller DKC	1-5
	Type Code Auxiliary Braking Resistor Module BZM.....	1-6
	Type Code for CZM Auxiliary Braking Resistor Module	1-6
2	Important directions for use	2-1
2.1	Appropriate use	2-1
	Introduction	2-1
	Areas of use and application.....	2-2
2.2	Inappropriate use	2-2
3	Safety Instructions for Electric Drives and Controls	3-1
3.1	Introduction.....	3-1
3.2	Explanations.....	3-1
3.3	Hazards by Improper Use	3-2
3.4	General Information	3-3
3.5	Protection Against Contact with Electrical Parts.....	3-5
3.6	Protection Against Electric Shock by Protective Low Voltage (PELV).....	3-6
3.7	Protection Against Dangerous Movements.....	3-7
3.8	Protection Against Magnetic and Electromagnetic Fields During Operation and Mounting	3-9
3.9	Protection Against Contact with Hot Parts	3-10
3.10	Protection During Handling and Mounting	3-10
3.11	Battery Safety.....	3-11
3.12	Protection Against Pressurized Systems	3-11
4	ECODRIVE03 DKC**.040, DKC**.100, DKC**.200	4-1
4.1	Technical Data	4-1
	Dimensions	4-1
	Ambient and operating conditions	4-4
	Electric Data of the Individual DKC**.3 Components	4-6
	Storable energy in the bus.....	4-17
	Mains supply options	4-19
	Number of ECODRIVE03 Units and Auxiliary Components on one DC bus.....	4-20

Selection criteria for supply options	4-21
Energy circuit DKC**.3 using "Central supply" as an example	4-26
Allowed DC bus Peak Power	4-27
Allowed DC bus continuous power without auxiliary components	4-28
Allowed DC bus continuous power with CZM01.3 auxiliary components	4-31
Allowed DC bus continuous power with CZM01.3 and GLD12 smoothing choke	4-34
Allowed DC bus continuous power with single-phase mains connection	4-36
CE label, C-UL listing, Tests	4-39
4.2 Electrical connections - independent of the drive controller type	4-40
A look at the drive controller and connector designations	4-40
Independent of the drive controller type – total connecting diagram	4-44
X1, Connections for Control voltage	4-45
X2, Serial Interface	4-49
X3, Digital and analog I/Os	4-53
X4, Encoder 1	4-59
X5, DC bus, Motor and Mains Connections	4-62
X6, Motor temperature monitoring and holding brakes	4-67
X7, Connection for Programming module	4-73
X8, Encoder 2	4-75
X9, Incremental and Absolute Encoder Emulation (SSI format)	4-81
X10, EcoX Expansion interface	4-86
X11, DC bus dynamic brake (ZKS), U_D power supply	4-88
X12, Optional Choke Connection for DKC**.3-200-7	4-93
XE1, XE2 Protective conductor connections for motor and mains	4-95
XS1, XS2, XS3 Shield Connections	4-96
4.3 Electrical Connections – dependent on the drive controller type	4-97
DKC 01.3-***-7-FW – Parallel Interface	4-97
DKC 02.3-***-7-FW – SERCOS interface	4-104
DKC 03.3-***-7-FW – Profibus-DP Interface	4-108
DKC 04.3-***-7-FW – InterBus Interface	4-114
DKC 05.3-***-7-FW – CANopen Interface	4-117
DKC 06.3-***-7-FW – DeviceNet Interface	4-119
DKC 11.3-***-7-FW – Analog Interface	4-121
DKC 21.3-***-7-FW – Parallel Interface 2	4-121
DKC 22.3-***-7-FW – SERCOS interface	4-125

5 ECODRIVE03 DKC.3-016 5-1**

5.1 Technical Data	5-1
Dimensions	5-1
Materials used, Mass	5-2
Ambient and operating conditions	5-3
Electric Data of the Individual DKC**.3-016 Components	5-4
Storable energy in the bus	5-9
Mains supply options	5-10
Allowed DC bus Peak Power	5-12
Allowed DC bus continuous power	5-12

Allowed DC bus continuous power with single-phase mains connection.....	5-13
CE label, C-UL listing, Tests.....	5-15
5.2 Electrical connections.....	5-16
A look at the drive controller and connector designations.....	5-16
Independent of the drive controller type – total connecting diagram.....	5-18
X1, Connections for control voltage.....	5-19
X2, Serial Interface.....	5-23
X3, Digital I/Os.....	5-25
X4, Encoder 1.....	5-29
X5, Motor and Mains Connections.....	5-32
X6, Motor temperature monitoring and holding brakes.....	5-36
X10, EcoX Expansion interface.....	5-41
XE1, XE2 Protective conductor connections for motor and mains.....	5-42
XS1, XS2, XS3 Shield Connections.....	5-43
H1, S1, S2, S3: Diagnostic display, Reset key, Address switch.....	5-44
6 ECODRIVE03 Auxiliary Bleeder Module BZM01.3	6-1
6.1 General.....	6-1
6.2 Technical data.....	6-1
Dimensions.....	6-1
Materials used, Mass.....	6-2
Ambient and operating conditions.....	6-3
Electrical data of auxiliary component BZM01.3.....	6-3
CE Label, Tests.....	6-5
6.3 Electrical Connections BZM01.3.....	6-6
Front View.....	6-6
Complete Terminal Diagram.....	6-7
X1, Control voltage connections.....	6-9
X2, DC bus dynamic brake (ZKS), Diagnostic Signals.....	6-11
X3, RS 232 Interface.....	6-17
X5, DC bus and Mains connection.....	6-17
XE1, Protective conductor connection for mains.....	6-20
XS1, XS2, Shield connections.....	6-20
Diagnostic LEDs and Reset Probe.....	6-21
7 ECODRIVE03 Auxiliary Capacitance Module CZM01.3	7-1
7.1 General.....	7-1
7.2 Technical data.....	7-2
Dimensions.....	7-2
Materials used, Mass.....	7-3
Ambient and operating conditions.....	7-3
Electrical Data of Auxiliary Component CZM01.3.....	7-3
CE Label, Tests.....	7-4
7.3 Electrical Connections of CZM01.3.....	7-5
Front View.....	7-5

	X5, DC bus connection	7-6
	XE1, Protective conductor connection for mains	7-8
8	Choke GLD 12	8-1
8.1	General.....	8-1
8.2	Dimensions and Mounting Dimensions.....	8-1
9	DC24V NTM power supplies	9-1
9.1	Application recommendations.....	9-1
9.2	Technical data.....	9-1
9.3	Dimensional sheets and installation dimensions	9-2
9.4	Front views.....	9-2
9.5	Electrical connection	9-3
9.6	Type code.....	9-4
10	DST transformers	10-1
10.1	Selection.....	10-1
10.2	Autotransformers for Drive Controllers	10-1
10.3	Type code.....	10-4
11	Mains Connections	11-1
11.1	General.....	11-1
11.2	The Ground Conditions of the Power Supply Network	11-1
11.3	Earth-leakage circuit breaker	11-2
11.4	Control Circuits for the Mains Connection	11-2
	Control Circuits with E-Stop	11-3
	Control Circuits with internal DC bus dynamic brake (ZKS)	11-5
11.5	Mains Contactor / Fuses	11-7
	Computing phase current on the mains.....	11-7
	Computing charging current inrush.....	11-8
	Factor F for Computing the Connected Load	11-9
	Q1 Fuse and K1 Contactor	11-12
12	Constructing the Control Cabinet	12-1
12.1	Notes on Control Cabinet Project Planning	12-1
	Power dissipation.....	12-1
	Mounting Position and Distances	12-6
	Module widths	12-11
	Arranging ECODRIVE03 Components in the Control Cabinet.....	12-12
12.2	Using Cooling Units in the Control Cabinet.....	12-14
12.3	General Notes	12-16
12.4	Wire routing in the Control Cabinet.....	12-17
12.5	EMC in the Control Cabinet	12-17
13	State of Delivery of the Drive Components	13-1
13.1	Packaging.....	13-1

13.2	Papers	13-2
13.3	Extent of Delivery	13-2
13.4	Ordering	13-4
	Unit Types Available	13-4
	Replacement Parts	13-4
	Additional Accessories	13-4
	Mounting Accessories	13-4
	Commissioning Aids	13-4
14	Identifying the Components	14-1
14.1	Component designations	14-1
	Type Plates	14-2
15	Replacing or Exchanging Drive Components	15-1
15.1	General	15-1
15.2	Procedure on Replacing the Unit	15-3
	Replacing the drive controller	15-3
	Replacing the Motor	15-4
	Replacing cables	15-4
15.3	Replacing Firmware (DKC**.3-040/100/200-7-FW)	15-7
	Replacing the Parameter Module	15-7
	Replacing the Firmware Module	15-8
	Replacing the Programming Module (complete module)	15-8
15.4	Replacing Firmware (DKC**.3-016-7-FW)	15-9
16	Attachment	16-1
16.1	Sizing relevant to supply and regeneration	16-1
	Requirements	16-1
	Calculations with regard to the power and energy allowed on the device side	16-2
	Calculations with regard to the power and energy resulting on the installation side	16-3
	Calculation with regard to reduction of resulting power dissipation	16-4
	Calculating the allowed continuous braking resistor and DC bus power	16-5
16.2	Use of the connections for looping through the control voltage	16-6
16.3	Control Cabinet Construction with Recommendations for EMC and Cooling	16-7
	Sectional Drawing for Developing an Optimum Control Cabinet	16-8
16.4	Wire routing and wiring of the drive controller	16-10
	DKC**.3-016 control connections	16-10
	Control connection DKC**.3-040/100/200	16-13
	Power connection	16-19
	RS485 - Connector	16-26
16.5	What is needed to prepare to start-up	16-27
16.6	Command Value Box Connection	16-28
16.7	Signal Sequence DKC**.3	16-29
	Recommended Switching On Sequence	16-29
	Recommended Off Sequence	16-31
16.8	Directory of Standards and Guidelines	16-33

17 Index	17-1
18 Service & Support	18-1
18.1 Helpdesk	18-1
18.2 Service-Hotline	18-1
18.3 Internet	18-1
18.4 Vor der Kontaktaufnahme... - Before contacting us.....	18-1
18.5 Kundenbetreuungsstellen - Sales & Service Facilities	18-2

1 Introduction to the System

1.1 Drive package ECODRIVE03

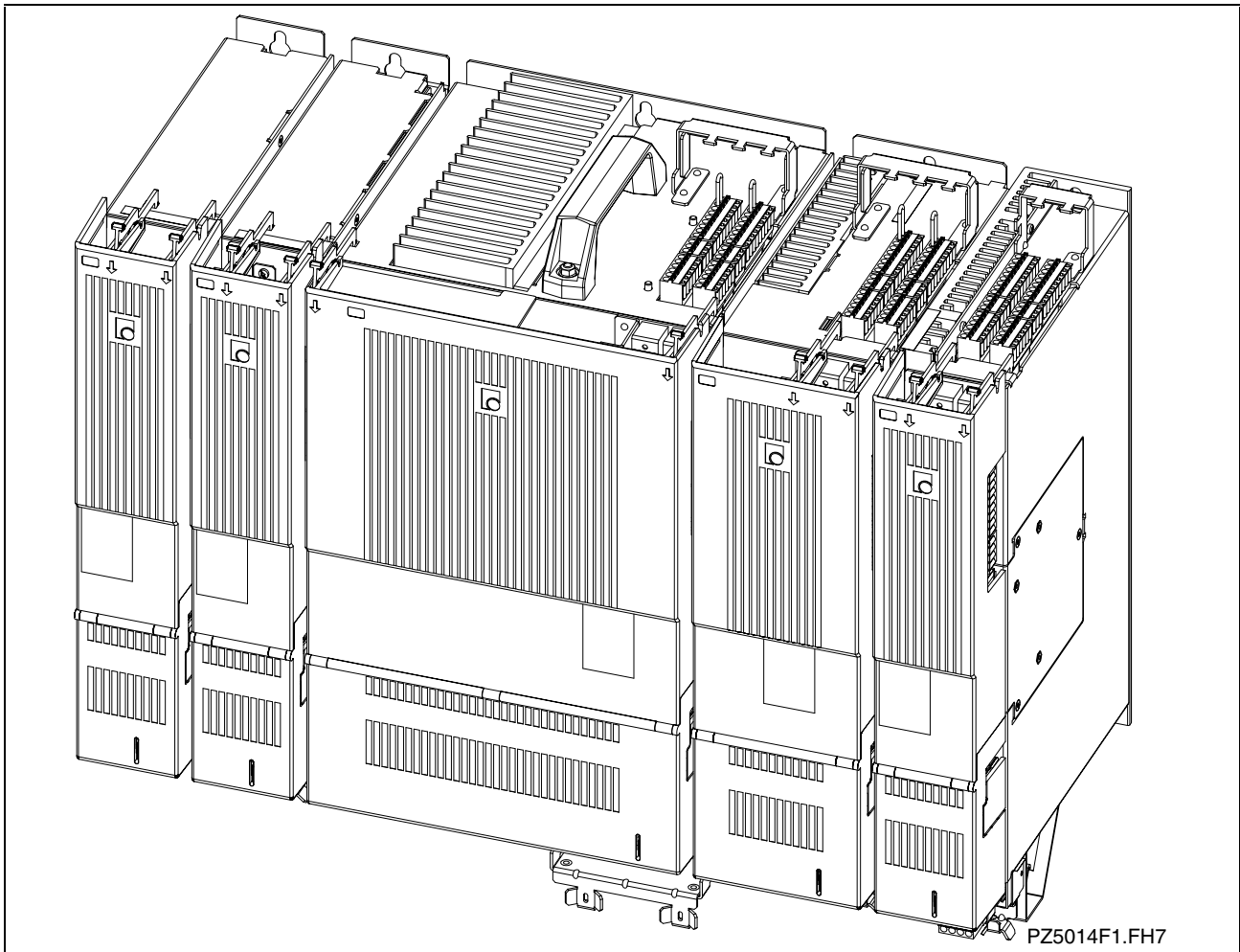

Fig. 1-1: Digital intelligent drive system

The digital intelligent automation system **ECODRIVE03** is the cost-effective solution with a high level of functionality for single and multiple axis drive and control tasks.

ECODRIVE03 can be used to implement a variety of drive tasks in the most varied applications. Different device types are available with graduated drive power.

Typical application areas are:

- handling systems
- packaging machines
- assembly systems
- printing machines
- machine tools

1.2 An Overview of Individual Components of the ECODRIVE03 Family

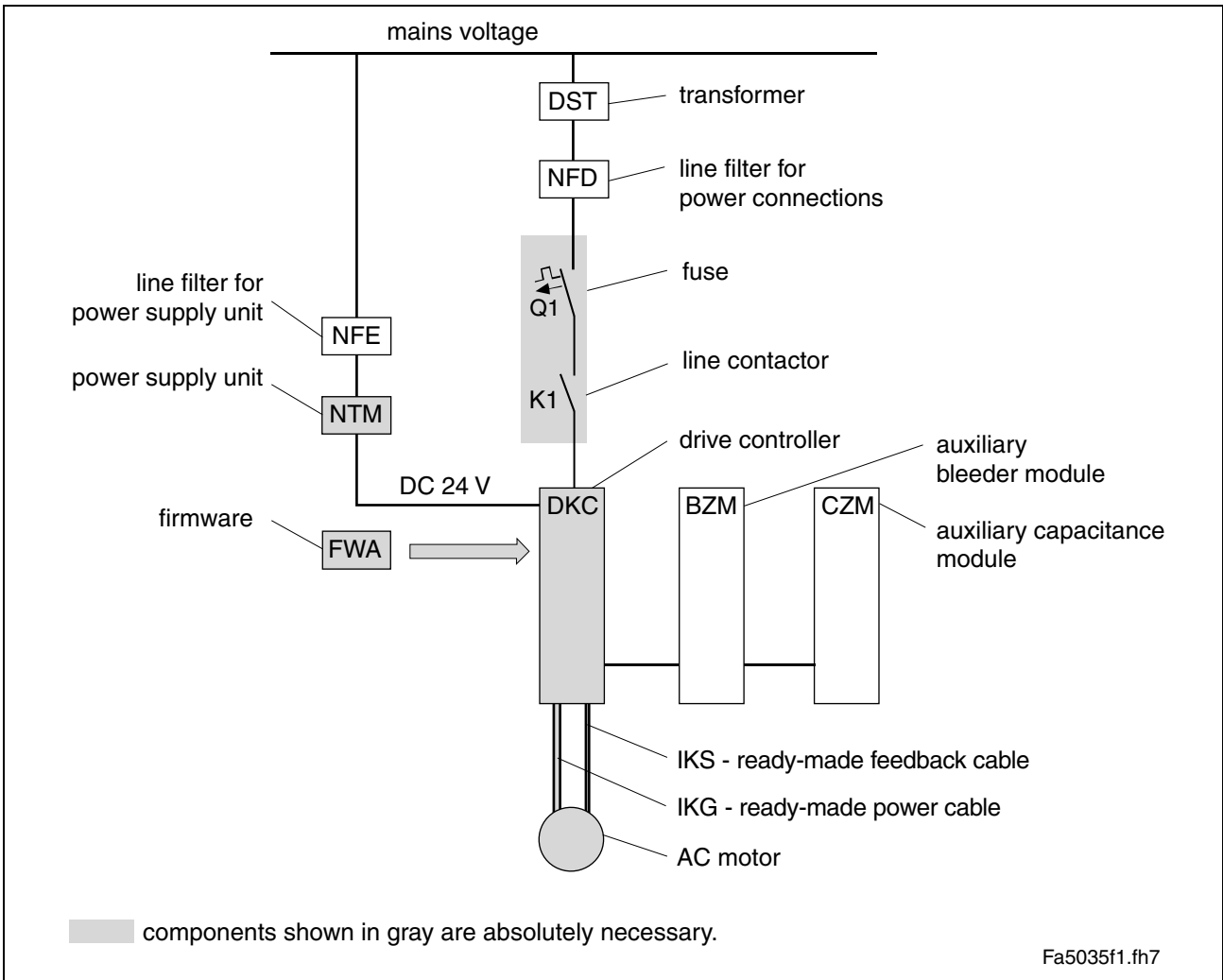

Fig. 1-2: Overview of individual components

1.3 An Overview of Drive Controllers and Auxiliary Components

An Overview of Communications Interfaces

Interface	Device type								
	DKC11.3*	DKC01.3	DKC21.3	DKC02.3	DKC22.3	DKC03.3	DKC04.3	DKC05.3	DKC06.3
RS232 / RS485*	X	X	X	X	X	X	X	X	X
Analog Interface	X	X	X	X	X	X	X	X	X
Parallel Interface		X							
Parallel Interface 2			X						
Stepper Interface		X							
SERCOS interface				X					
SERCOS interface 2					X				
Profibus-DP Interface						X			
InterBus Interface							X		
CANopen Interface								X	
DeviceNet Interface									X

* The DKC11.3 device type resp. the RS485 interface does not exist for the DKC**.3-016-7-FW drive controllers.

Fig. 1-3: An overview of interfaces

An Overview of Measuring Systems Supported

Connecting the Systems to the Encoder Inputs

Type of motor	Encoder 1 (plug X4)			Encoder 2 (plug X8)				
	Digital servo-feedback (1)		Resolver with FDS (2)	Resolver without FDS (3)	Sine encoder (4)	EnDat encoder (5)	Gear-type encoder with 1Vss signals (6)	Square-wave encoder with 5V TTL signals (7)
	DSF	HSF						
MKD			X					
MKE			X					
MHD		X						
2AD	X	X					X ^{*)}	
ADF	X	X					X ^{*)}	
1MB					X	X	X ^{*)}	
MBW					X	X	X ^{*)}	
LAR					X	X	X ^{*)}	
LAF					X	X	X ^{*)}	
LSF						X		
MBS				X	X	X		

Fig. 1-4: Connecting the measuring systems

- (1) : single-turn or multi-turn DSF / HSF
- (2) : resolver or multi-turn resolver (RSF) with feedback data storage (FDS)
- (3) : resolver or multi-turn resolver (RSF) without feedback data storage (FDS)
- (4) : incremental measuring system with sine signals (1Vss signals)
- (5) : absolute measuring system with EnDat interface
- (6) : gear-type encoder with 1Vss signals
(The drive controller does not compensate the offset of an uncompensated gear-type encoder.)
- (7) : square-wave encoder with 5V TTL signals;
not recommended (due to maximum input frequency of 200 kHz)

Note: It is only resolvers with FDS that can be connected to the DKC**.3-016-7-FW drive controllers.

Note: The cable type designations of the connecting cables required are listed in the motor project planning manual or "List of Connecting Cables for DIAX04 and ECODRIVE03".

See also the functional description: "Setting the Measurement System".

Type Code for Drive Controller DKC

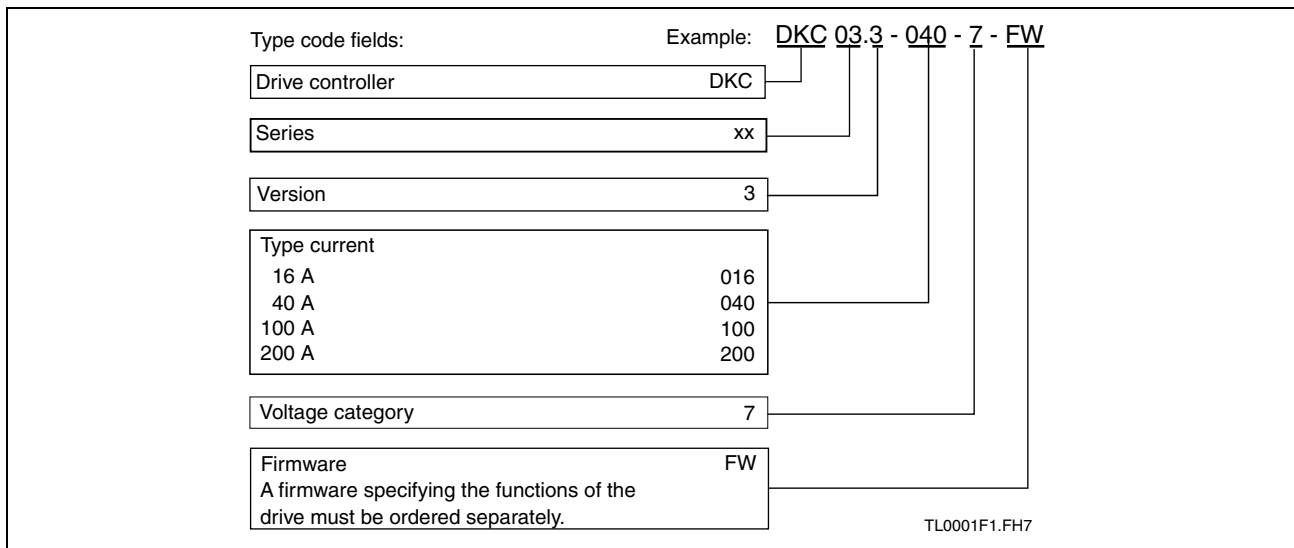

Fig. 1-5: Type code

Note: The above illustrates how the type codes are put together. Your sales representative will help with the current status of available versions.

Type Code Auxiliary Braking Resistor Module BZM

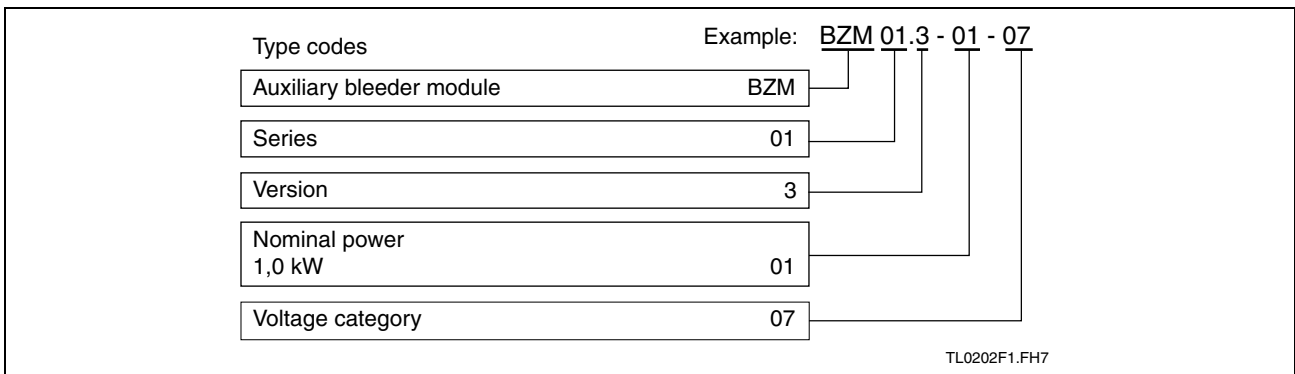

Fig. 1-6: Type Code

Type Code for CZM Auxiliary Braking Resistor Module

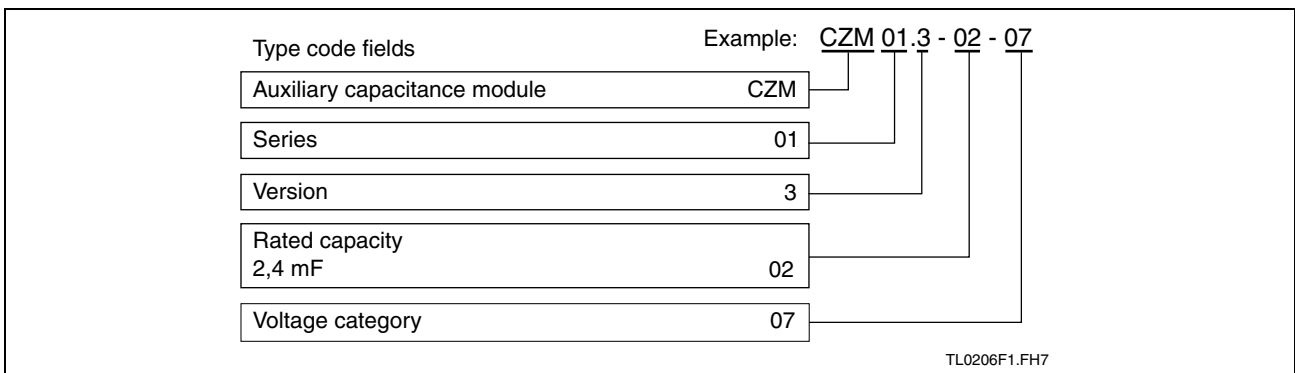

Fig. 1-7: Type code

2 Important directions for use

2.1 Appropriate use

Introduction

Rexroth Indramat products represent state-of-the-art developments and manufacturing. They are tested prior to delivery to ensure operating safety and reliability.

The products may only be used in the manner that is defined as appropriate. If they are used in an inappropriate manner, then situations can develop that may lead to property damage or injury to personnel.

Note: Rexroth Indramat, as manufacturer, is not liable for any damages resulting from inappropriate use. In such cases, the guarantee and the right to payment of damages resulting from inappropriate use are forfeited. The user alone carries all responsibility of the risks.

Before using Rexroth Indramat products, make sure that all the prerequisites for an appropriate use of the products are satisfied:

- Personnel that in any way, shape or form uses our products must first read and understand the relevant safety instructions and be familiar with appropriate use.
- If the product takes the form of hardware, then they must remain in their original state, in other words, no structural changes are permitted. It is not permitted to decompile software products or alter source codes.
- Do not mount damaged or faulty products or use them in operation.
- Make sure that the products have been installed in the manner described in the relevant documentation.

Areas of use and application

Drive controllers made by Rexroth Indramat are designed to control electrical motors and monitor their operation.

Control and monitoring of the motors may require additional sensors and actors.

Note: The drive controllers may only be used with the accessories and parts specified in this document. If a component has not been specifically named, then it may not be either mounted or connected. The same applies to cables and lines.

Operation is only permitted in the specified configurations and combinations of components using the software and firmware as specified in the relevant function descriptions.

Every drive controller has to be programmed before starting it up, making it possible for the motor to execute the specific functions of an application.

The drive controllers of the ECODRIVE03 family are designed for use in single or multiple-axis drive and control applications.

To ensure an application-specific use, the drive controllers are available with differing drive power and different interfaces.

Typical applications of drive controllers belonging to the ECODRIVE03 family are:

- handling and mounting systems,
- packaging and foodstuff machines,
- printing and paper processing machines and
- machine tools.

The drive controllers may only be operated under the assembly, installation and ambient conditions as described here (temperature, system of protection, humidity, EMC requirements, etc.) and in the position specified.

2.2 Inappropriate use

Using the drive controllers outside of the above-referenced areas of application or under operating conditions other than described in the document and the technical data specified is defined as "inappropriate use".

Drive controllers may not be used if

- they are subject to operating conditions that do not meet the above specified ambient conditions. This includes, for example, operation under water, in the case of extreme temperature fluctuations or extremely high maximum temperatures or if
- Rexroth Indramat has not specifically released them for that intended purpose. Please note the specifications outlined in the general safety instructions!

3 Safety Instructions for Electric Drives and Controls

3.1 Introduction

Read these instructions before the initial startup of the equipment in order to eliminate the risk of bodily harm or material damage. Follow these safety instructions at all times.

Do not attempt to install or start up this equipment without first reading all documentation provided with the product. Read and understand these safety instructions and all user documentation of the equipment prior to working with the equipment at any time. If you do not have the user documentation for your equipment, contact your local Rexroth Indramat representative to send this documentation immediately to the person or persons responsible for the safe operation of this equipment.

If the equipment is resold, rented or transferred or passed on to others, then these safety instructions must be delivered with the equipment.



WARNING

Improper use of this equipment, failure to follow the safety instructions in this document or tampering with the product, including disabling of safety devices, may result in material damage, bodily harm, electric shock or even death!

3.2 Explanations

The safety instructions describe the following degrees of hazard seriousness in compliance with ANSI Z535. The degree of hazard seriousness informs about the consequences resulting from non-compliance with the safety instructions.



Warning symbol with signal word	Degree of hazard seriousness according to ANSI
 DANGER	Death or severe bodily harm will occur.
 WARNING	Death or severe bodily harm may occur.
 CAUTION	Bodily harm or material damage may occur.

Fig. 3-1: Hazard classification (according to ANSI Z535)

3.3 Hazards by Improper Use



DANGER

**High voltage and high discharge current!
Danger to life or severe bodily harm by electric shock!**



DANGER

Dangerous movements! Danger to life, severe bodily harm or material damage by unintentional motor movements!



WARNING

High electrical voltage due to wrong connections! Danger to life or bodily harm by electric shock!



WARNING

Health hazard for persons with heart pacemakers, metal implants and hearing aids in proximity to electrical equipment!



CAUTION

Surface of machine housing could be extremely hot! Danger of injury! Danger of burns!



CAUTION

Risk of injury due to improper handling! Bodily harm caused by crushing, shearing, cutting and mechanical shock or incorrect handling of pressurized systems!



CAUTION

Risk of injury due to incorrect handling of batteries!

3.4 General Information

- Rexroth Indramat GmbH is not liable for damages resulting from failure to observe the warnings provided in this documentation.
- Read the operating, maintenance and safety instructions in your language before starting up the machine. If you find that you cannot completely understand the documentation for your product, please ask your supplier to clarify.
- Proper and correct transport, storage, assembly and installation as well as care in operation and maintenance are prerequisites for optimal and safe operation of this equipment.
- Only persons who are trained and qualified for the use and operation of the equipment may work on this equipment or within its proximity.

The persons are qualified if they have sufficient knowledge of the assembly, installation and operation of the equipment as well as an understanding of all warnings and precautionary measures noted in these instructions.

Furthermore, they must be trained, instructed and qualified to switch electrical circuits and equipment on and off in accordance with technical safety regulations, to ground them and to mark them according to the requirements of safe work practices. They must have adequate safety equipment and be trained in first aid.

- Only use spare parts and accessories approved by the manufacturer.
- Follow all safety regulations and requirements for the specific application as practiced in the country of use.
- The equipment is designed for installation in industrial machinery.
- The ambient conditions given in the product documentation must be observed.
- Use only safety features and applications that are clearly and explicitly approved in the Project Planning Manual.
For example, the following areas of use are not permitted: construction cranes, elevators used for people or freight, devices and vehicles to transport people, medical applications, refinery plants, transport of hazardous goods, nuclear applications, applications sensitive to high frequency, mining, food processing, control of protection equipment (also in a machine).
- The information given in this documentation with regard to the use of the delivered components contains only examples of applications and suggestions.

The machine and installation manufacturer must

make sure that the delivered components are suited for his individual application and check the information given in this documentation with regard to the use of the components,

make sure that his application complies with the applicable safety regulations and standards and carry out the required measures, modifications and complements.

- Startup of the delivered components is only permitted once it is sure that the machine or installation in which they are installed complies with the national regulations, safety specifications and standards of the application.

- Operation is only permitted if the national EMC regulations for the application are met.
The instructions for installation in accordance with EMC requirements can be found in the documentation "EMC in Drive and Control Systems".
The machine or installation manufacturer is responsible for compliance with the limiting values as prescribed in the national regulations.
- Technical data, connections and operational conditions are specified in the product documentation and must be followed at all times.

3.5 Protection Against Contact with Electrical Parts

Note: This section refers to equipment and drive components with voltages above 50 Volts.

Touching live parts with voltages of 50 Volts and more with bare hands or conductive tools or touching ungrounded housings can be dangerous and cause electric shock. In order to operate electrical equipment, certain parts must unavoidably have dangerous voltages applied to them.



DANGER

High electrical voltage! Danger to life, severe bodily harm by electric shock!

- ⇒ Only those trained and qualified to work with or on electrical equipment are permitted to operate, maintain or repair this equipment.
 - ⇒ Follow general construction and safety regulations when working on high voltage installations.
 - ⇒ Before switching on power the ground wire must be permanently connected to all electrical units according to the connection diagram.
 - ⇒ Do not operate electrical equipment at any time, even for brief measurements or tests, if the ground wire is not permanently connected to the points of the components provided for this purpose.
 - ⇒ Before working with electrical parts with voltage higher than 50 V, the equipment must be disconnected from the mains voltage or power supply. Make sure the equipment cannot be switched on again unintended.
 - ⇒ The following should be observed with electrical drive and filter components:
 - ⇒ Wait five (5) minutes after switching off power to allow capacitors to discharge before beginning to work. Measure the voltage on the capacitors before beginning to work to make sure that the equipment is safe to touch.
 - ⇒ Never touch the electrical connection points of a component while power is turned on.
 - ⇒ Install the covers and guards provided with the equipment properly before switching the equipment on. Prevent contact with live parts at any time.
 - ⇒ A residual-current-operated protective device (RCD) must not be used on electric drives! Indirect contact must be prevented by other means, for example, by an overcurrent protective device.
 - ⇒ Electrical components with exposed live parts and uncovered high voltage terminals must be installed in a protective housing, for example, in a control cabinet.
-

To be observed with electrical drive and filter components:



DANGER

**High electrical voltage on the housing!
High leakage current! Danger to life, danger of
injury by electric shock!**

- ⇒ Connect the electrical equipment, the housings of all electrical units and motors permanently with the safety conductor at the ground points before power is switched on. Look at the connection diagram. This is even necessary for brief tests.
- ⇒ Connect the safety conductor of the electrical equipment always permanently and firmly to the supply mains. Leakage current exceeds 3.5 mA in normal operation.
- ⇒ Use a copper conductor with at least 10 mm² cross section over its entire course for this safety conductor connection!
- ⇒ Prior to startups, even for brief tests, always connect the protective conductor or connect with ground wire. Otherwise, high voltages can occur on the housing that lead to electric shock.

3.6 Protection Against Electric Shock by Protective Low Voltage (PELV)

All connections and terminals with voltages between 0 and 50 Volts on Rexroth Indramat products are protective low voltages designed in accordance with international standards on electrical safety.



WARNING

**High electrical voltage due to wrong
connections! Danger to life, bodily harm by
electric shock!**

- ⇒ Only connect equipment, electrical components and cables of the protective low voltage type (PELV = Protective Extra Low Voltage) to all terminals and clamps with voltages of 0 to 50 Volts.
- ⇒ Only electrical circuits may be connected which are safely isolated against high voltage circuits. Safe isolation is achieved, for example, with an isolating transformer, an opto-electronic coupler or when battery-operated.

3.7 Protection Against Dangerous Movements

Dangerous movements can be caused by faulty control of the connected motors. Some common examples are:

- improper or wrong wiring of cable connections
- incorrect operation of the equipment components
- wrong input of parameters before operation
- malfunction of sensors, encoders and monitoring devices
- defective components
- software or firmware errors

Dangerous movements can occur immediately after equipment is switched on or even after an unspecified time of trouble-free operation.

The monitoring in the drive components will normally be sufficient to avoid faulty operation in the connected drives. Regarding personal safety, especially the danger of bodily injury and material damage, this alone cannot be relied upon to ensure complete safety. Until the integrated monitoring functions become effective, it must be assumed in any case that faulty drive movements will occur. The extent of faulty drive movements depends upon the type of control and the state of operation.

**DANGER**

Dangerous movements! Danger to life, risk of injury, severe bodily harm or material damage!

- ⇒ Ensure personal safety by means of qualified and tested higher-level monitoring devices or measures integrated in the installation. Unintended machine motion is possible if monitoring devices are disabled, bypassed or not activated.
- ⇒ Pay attention to unintended machine motion or other malfunction in any mode of operation.

- ⇒ Keep free and clear of the machine's range of motion and moving parts. Possible measures to prevent people from accidentally entering the machine's range of motion:
 - use safety fences
 - use safety guards
 - use protective coverings
 - install light curtains or light barriers
- ⇒ Fences and coverings must be strong enough to resist maximum possible momentum, especially if there is a possibility of loose parts flying off.
- ⇒ Mount the emergency stop switch in the immediate reach of the operator. Verify that the emergency stop works before startup. Don't operate the machine if the emergency stop is not working.
- ⇒ Isolate the drive power connection by means of an emergency stop circuit or use a starting lockout to prevent unintentional start.
- ⇒ Make sure that the drives are brought to a safe standstill before accessing or entering the danger zone. Safe standstill can be achieved by switching off the power supply contactor or by safe mechanical locking of moving parts.
- ⇒ Secure vertical axes against falling or dropping after switching off the motor power by, for example:
 - mechanically securing the vertical axes
 - adding an external braking/ arrester/ clamping mechanism
 - ensuring sufficient equilibration of the vertical axes

The standard equipment motor brake or an external brake controlled directly by the drive controller are not sufficient to guarantee personal safety!

- ⇒ Disconnect electrical power to the equipment using a master switch and secure the switch against reconnection for:
 - maintenance and repair work
 - cleaning of equipment
 - long periods of discontinued equipment use
 - ⇒ Prevent the operation of high-frequency, remote control and radio equipment near electronics circuits and supply leads. If the use of such equipment cannot be avoided, verify the system and the installation for possible malfunctions in all possible positions of normal use before initial startup. If necessary, perform a special electromagnetic compatibility (EMC) test on the installation.
-

3.8 Protection Against Magnetic and Electromagnetic Fields During Operation and Mounting

Magnetic and electromagnetic fields generated near current-carrying conductors and permanent magnets in motors represent a serious health hazard to persons with heart pacemakers, metal implants and hearing aids.



WARNING

Health hazard for persons with heart pacemakers, metal implants and hearing aids in proximity to electrical equipment!

- ⇒ Persons with heart pacemakers, hearing aids and metal implants are not permitted to enter the following areas:
 - Areas in which electrical equipment and parts are mounted, being operated or started up.
 - Areas in which parts of motors with permanent magnets are being stored, operated, repaired or mounted.
 - ⇒ If it is necessary for a person with a heart pacemaker to enter such an area, then a doctor must be consulted prior to doing so. Heart pacemakers that are already implanted or will be implanted in the future, have a considerable variation in their electrical noise immunity. Therefore there are no rules with general validity.
 - ⇒ Persons with hearing aids, metal implants or metal pieces must consult a doctor before they enter the areas described above. Otherwise, health hazards will occur.
-

3.9 Protection Against Contact with Hot Parts



CAUTION

**Housing surfaces could be extremely hot!
Danger of injury! Danger of burns!**

- ⇒ Do not touch housing surfaces near sources of heat! Danger of burns!
- ⇒ After switching the equipment off, wait at least ten (10) minutes to allow it to cool down before touching it.
- ⇒ Do not touch hot parts of the equipment, such as housings with integrated heat sinks and resistors. Danger of burns!

3.10 Protection During Handling and Mounting

Under certain conditions, incorrect handling and mounting of parts and components may cause injuries.



CAUTION

Risk of injury by incorrect handling! Bodily harm caused by crushing, shearing, cutting and mechanical shock!

- ⇒ Observe general installation and safety instructions with regard to handling and mounting.
- ⇒ Use appropriate mounting and transport equipment.
- ⇒ Take precautions to avoid pinching and crushing.
- ⇒ Use only appropriate tools. If specified by the product documentation, special tools must be used.
- ⇒ Use lifting devices and tools correctly and safely.
- ⇒ For safe protection wear appropriate protective clothing, e.g. safety glasses, safety shoes and safety gloves.
- ⇒ Never stand under suspended loads.
- ⇒ Clean up liquids from the floor immediately to prevent slipping.

3.11 Battery Safety

Batteries contain reactive chemicals in a solid housing. Inappropriate handling may result in injuries or material damage.



CAUTION

Risk of injury by incorrect handling!

- ⇒ Do not attempt to reactivate discharged batteries by heating or other methods (danger of explosion and cauterization).
- ⇒ Never charge non-chargeable batteries (danger of leakage and explosion).
- ⇒ Never throw batteries into a fire.
- ⇒ Do not dismantle batteries.
- ⇒ Do not damage electrical components installed in the equipment.

Note: Be aware of environmental protection and disposal! The batteries contained in the product should be considered as hazardous material for land, air and sea transport in the sense of the legal requirements (danger of explosion). Dispose batteries separately from other waste. Observe the legal requirements in the country of installation.

3.12 Protection Against Pressurized Systems

Certain motors and drive controllers, corresponding to the information in the respective Project Planning Manual, must be provided with pressurized media, such as compressed air, hydraulic oil, cooling fluid and cooling lubricant supplied by external systems. Incorrect handling of the supply and connections of pressurized systems can lead to injuries or accidents. In these cases, improper handling of external supply systems, supply lines or connections can cause injuries or material damage.



CAUTION

Danger of injury by incorrect handling of pressurized systems !

- ⇒ Do not attempt to disassemble, to open or to cut a pressurized system (danger of explosion).
- ⇒ Observe the operation instructions of the respective manufacturer.
- ⇒ Before disassembling pressurized systems, release pressure and drain off the fluid or gas.
- ⇒ Use suitable protective clothing (for example safety glasses, safety shoes and safety gloves)
- ⇒ Remove any fluid that has leaked out onto the floor immediately.

Note: Environmental protection and disposal! The media used in the operation of the pressurized system equipment may not be environmentally compatible. Media that are damaging the environment must be disposed separately from normal waste. Observe the legal requirements in the country of installation.

Notes

4 ECDRIVE03 DKC**.040, DKC**.100, DKC**.200

4.1 Technical Data

Dimensions

Drive Controller DKC**.3-040-7-FW

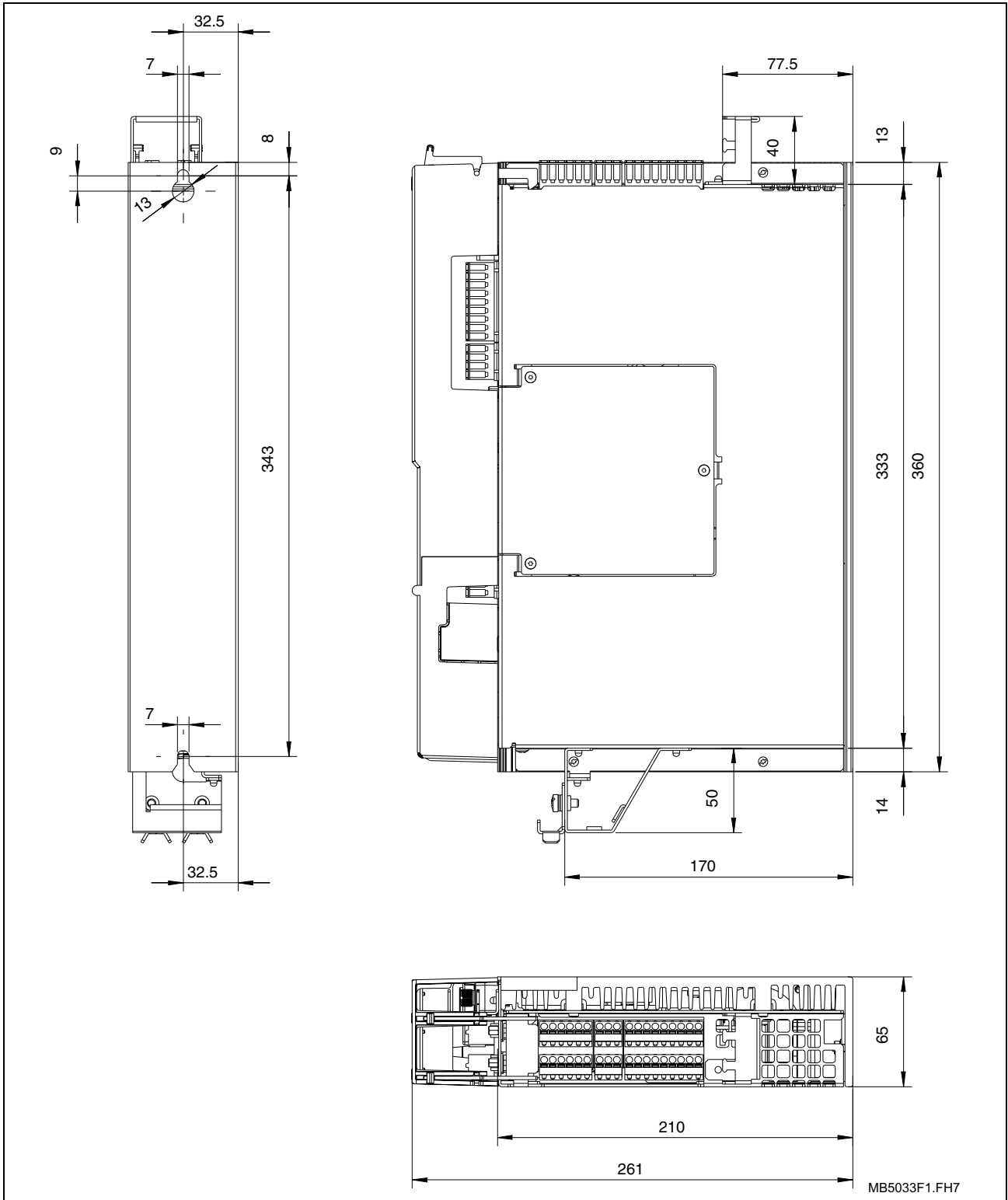
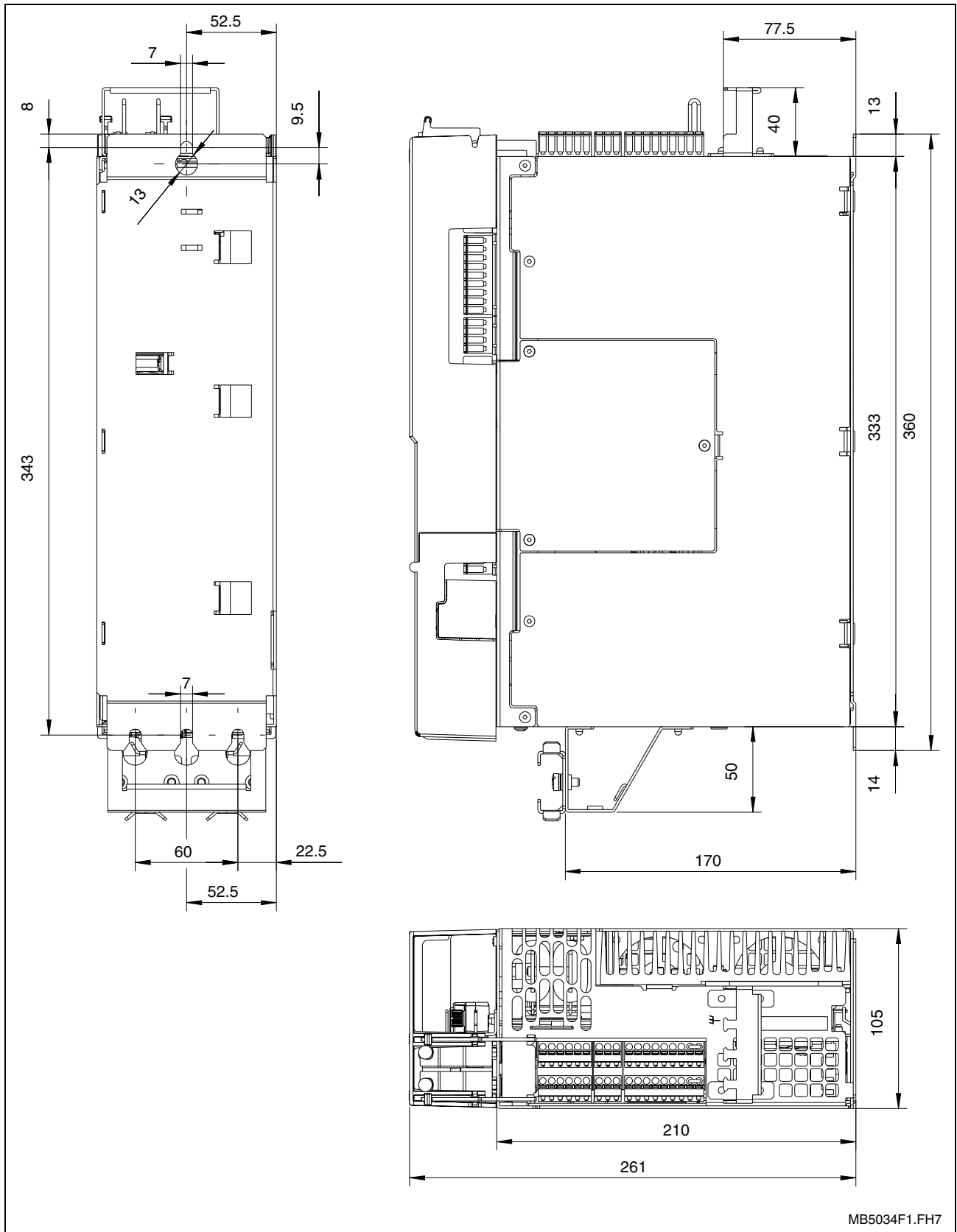

Fig. 4-1: Drive Controller DKC**.3-040-7-FW

Drive Controller DKC**.3-100-7-FW



MB5034F1.FH7

Fig. 4-2: Drive Controller DKC**.3-100-7-FW

Drive Controller DKC**.3-200-7-FW

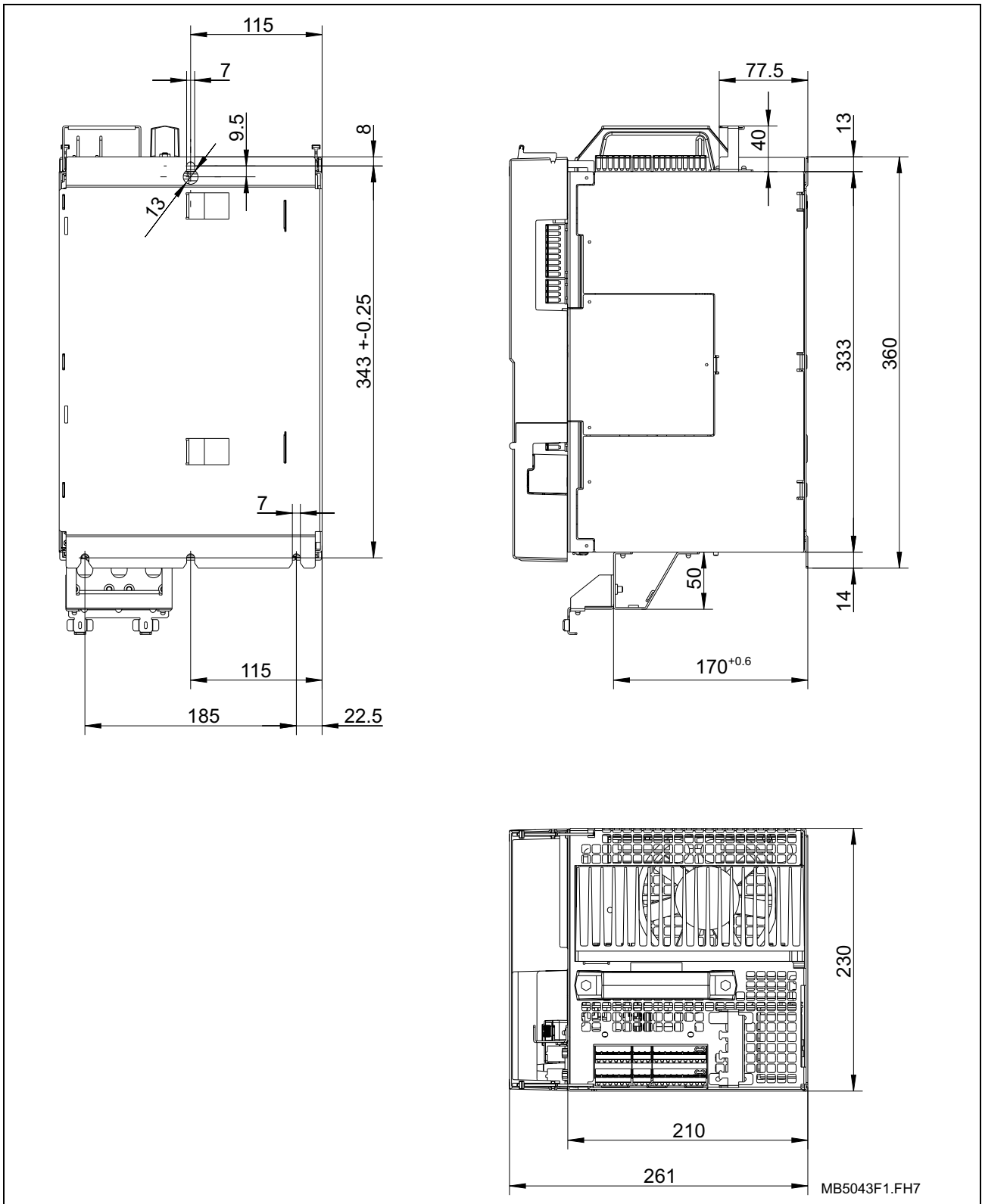

Fig. 4-3: Drive Controller DKC**.3-200-7-FW

Ambient and operating conditions

Note: ECODRIVE03 drive control devices and its auxiliary components are designed for control cabinet mounting.

Ambient temperature and installation altitude

Selection lists are specified for each motor/drive combination.

The selection lists apply to motors and drives within the specified ambient and operating conditions (see "Fig. 4-5: Ambient and operating conditions").

Differing conditions reduce the performance specifications

- of the drive:
 - allowed DC bus continuous output
 - continuous bleeder output
 - continuous current
- of the motor:
 - output
 - continuous torque at standstill
 - S1 continuous torque
 - Short-time operating torque M_{KB}

according to the diagrams (see "Fig. 4-4: Degree of utilization as a value dependent on ambient temperature and installation altitude"). If deviating ambient temperatures and higher installation altitudes occur simultaneously, both utilization factors must be multiplied. The installation altitude must only be taken into account once. Deviating ambient temperatures must be taken into account separately for motor and drive controller.

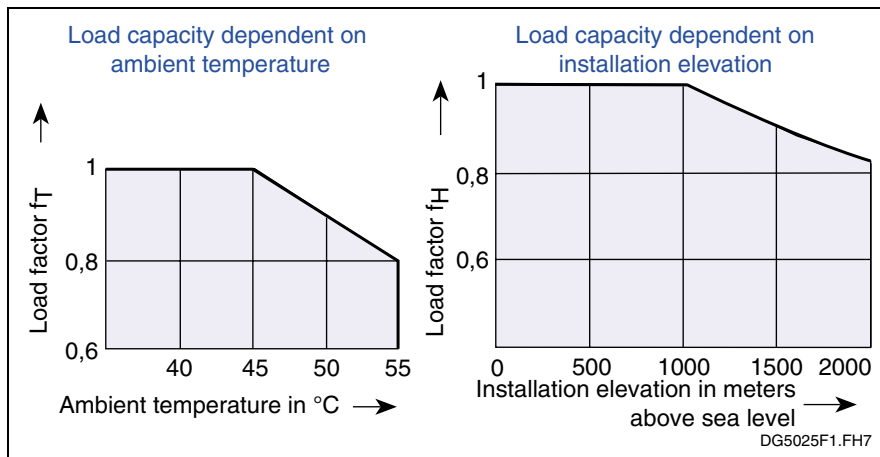

Fig. 4-4: Degree of utilization as a value dependent on ambient temperature and installation altitude

Designation	Symbol	Unit	DKC**.3-**-7-FW
Permissible ambient and air inlet temperature for the output ratings	T_A	°C	+5 ... +45
Max. permissible ambient and air inlet temperature for reduced output ratings	T_A	°C	The values specified in the selection lists for output and torque are reduced in the range +45...+55 °C by 2% per °C temperature increase
Storage and shipping temperatures	T_L	°C	-30 ... +85
Max. allowed installation altitude for the output ratings		m	1000
Max. allowed installation altitude		m	2000
Max. permissible relative humidity		%	95
Max. permissible absolute humidity		g/m ³	25
Allowable degree of contamination	2, according to EN 50178 fine dust no allowed, no condensation		
Type of protection	IP20, according to EN 60529 = DIN VDE 0470-1-1992 (ICE 529-1989)		
Vibration sinus in operation according to EN 60068-2-6			
Amplitude and Frequency			0.3 mm (peak-to-peak) at 5 ... 57 Hz 2 g at 57 ... 500 Hz
Tolerance		%	± 15
Vibration distortion (Random) in operation according to IEC 68-2-36			
Frequency		Hz	20 ... 500
Spectral acceleration density amplitude		g ² /Hz	0.01
Tolerance		dB	± 3
Virtual value (r.m.s.) of the total acceleration		g	2.2
Shock check not in operation according to EN 60068-2-27			
Halve sine in 3 axis			15 g / 11 ms

Fig. 4-5: Ambient and operating conditions

Note: The user must check that the ambient conditions are maintained, especially the control cabinet temperature, by calculating the thermal performance of the control cabinet.

Electric Data of the Individual DKC**.3 Components

Mains connections, Power section DKC**.3-040-7-FW and DKC**.3-100-7-FW

Designation	Symbol	Unit	DKC**.3-040-7-FW		DKC**.3-100-7-FW	
			single phase	three phase	single phase	three phase
Operating mode at the mains			single phase	three phase	single phase	three phase
Mains input voltage	U_{N1}	V	1 x AC (200 ... 480) \pm 10%	3 x AC	1 x AC (200 ... 480) \pm 10%	3 x AC
Mains frequency	f_{N1}	Hz	(50 ... 60) \pm 2			
Rotary field			clockwise or counter-clockwise			
Connected load	S_{N1}	kVA	see page 11-1: "Mains Connections"			
Nominal charging current (dependent on mains input voltage)	I_{EIN1}	A	5 ... 12		12 ... 28	
Soft-start resistor	$R_{Softstart}$	Ohm	60		24	
Continuous power soft-start resistor	$P_{Softstart}$	kW	0.15 ²⁾		0.5 ³⁾	
Switching frequency (selectable)	f_S	kHz	4 or 8			
Type current = peak current 1	I_{PEAK1}	A	40 ¹⁾		100 ¹⁾	
Peak current 2 for $f_S = 4$ kHz	$I_{PEAK2(4kHz)}$	A	16 ¹⁾		40 ¹⁾	
Peak current 2 for $f_S = 8$ kHz	$I_{PEAK2(8kHz)}$	A	12.5 ¹⁾		32 ¹⁾	
Continuous current 1 for $f_S = 4$ kHz	$I_{CONT1(4kHz)}$	A	13 ¹⁾		32 ¹⁾	
Continuous current 2 for $f_S = 4$ kHz	$I_{CONT2(4kHz)}$	A	16 ¹⁾		40 ¹⁾	
Continuous current 1 for $f_S = 8$ kHz	$I_{CONT1(8kHz)}$	A	9 ¹⁾		21 ¹⁾	
Continuous current 2 for $f_S = 8$ kHz	$I_{CONT2(8kHz)}$	A	12.5 ¹⁾		32 ¹⁾	
Max. output frequency at $f_S=4$ kHz	f_{out}	Hz	400		400	
Max. output frequency at $f_S=8$ kHz	f_{out}	Hz	800		800	
Device power dissipation without internal continuous bleeder power for I_{CONT2}	P_V	W	180 (see page 12-1: "Power dissipation")		420	
Peak bleeder power DKC when $U_{ZW} = 850$ V for permissible load cycle	P_{BS}	kW	10 0.5 s on, 33 s off		120 0.25 s on, 60 s off	
Continuous bleeder power DKC when $T_a \leq 45$ °C under max. temperature range with distance	P_{BD} ΔT d	kW K mm	0.15 28 80		0.5 150 80	
Max. energy dissipation	$W_{R,MAX}$	kWs	5.0		31	
Max. DC bus charge	W_{MAX}	kWs	5.0		31	
Internal DC bus dynamic brake (ZKS)			not present		present	
Resistor for ZKS	R_{ZKS}	Ohm	not present		6	
Storable energy of the DC bus capacitors	W_{ZW}	Ws	see diagrams page 4-17: "Storable energy in the bus"			
Nominal DC bus capacitance DKC	C_{ZW}	mF	0.27 \pm 20%		0.675 \pm 20%	
DC bus voltage (dependent on mains input voltage)	U_{ZW}	V	DC 300 ... 800			
DC bus continuous power (dependent on mains input voltage)	P_{ZWD}		see diagrams page 4-28 "Allowed DC bus continuous power"			

Designation	Symbol	Unit	DKC**.3-040-7-FW	DKC**.3-100-7-FW
max. DC bus continuous power for a single source supply where $U_{N1} = 3 \times \text{AC } 400\text{V}$, at $T_a \leq 45^\circ\text{C}$	P_{ZWD}	kW	1.3	3.3
max. DC bus continuous power for a single source supply where $U_{N1} = 3 \times \text{AC } 480\text{V}$, when $T_a \leq 45^\circ\text{C}$	P_{ZWD}	kW	1.5	4
max. DC bus continuous power for a single source supply where $U_{N1} = 3 \times \text{AC } 400\text{V}$, CZM01.3, when $T_a \leq 45^\circ\text{C}$	P_{ZWD}	kW	1.3	10.5
max. DC bus continuous power for a single source supply where $U_{N1} = 3 \times \text{AC } 480\text{V}$, CZM01.3, when $T_a \leq 45^\circ\text{C}$	P_{ZWD}	kW	1.5	12
DC bus peak power	P_{ZWS}		see diagrams on page 4-27 "DC bus peak power"	
Power section cooling			with internal blower	
Cooling the bleeder resistor			with internal blower via heatsink and back wall of unit	with internal blower
Cooling air flow			together for bleeder and power section	
Volumetric capacity of the forced cooling		m ³ /h	approx. 24	approx. 48
Insulation resistance at DC500V	R_{is}	MOhm	> 8	> 8
Coupling capacitance power section against housing	C_{Kop}	nF	200	200

Fig. 4-6: Technical Data Mains connection and Power section

Mains connections, Power section DKC**.3-200-7-FW

Designation	Symbol	Unit	DKC**.3-200-7-FW	
			single phase	three phase
Operating mode at the mains			single phase	three phase
Mains input voltage	U_{N1}	V	1 x AC (200 ... 480) \pm 10%	3 x AC
Mains frequency	f_{N1}	Hz	(50 ... 60) \pm 2	
Rotary field			clockwise or counter-clockwise	
Connected load	S_{N1}	kVA	see page 11-1: "Mains Connections"	
Nominal charging current (dependent on mains input voltage)	I_{EIN}	A	12 ... 28	
Soft-start resistor	$R_{Softstart}$	Ohm	24	
Continuous power soft-start resistor	$P_{Softstart}$	kW	1 ³⁾	
Switching frequency (selectable)	f_S	kHz	4 or 8	
Type current = peak current 1	I_{PEAK1}	A	200 ¹⁾	
Peak current 2 for $f_S = 4$ kHz	$I_{PEAK2(4kHz)}$	A	100 ¹⁾	
Peak current 2 for $f_S = 8$ kHz	$I_{PEAK2(8kHz)}$	A	68 ¹⁾	
Continuous current 1 for $f_S = 4$ kHz	$I_{CONT1(4kHz)}$	A	85 ¹⁾	
Continuous current 2 for $f_S = 4$ kHz	$I_{CONT2(4kHz)}$	A	100 ¹⁾	
Continuous current 1 for $f_S = 8$ kHz	$I_{CONT1(8kHz)}$	A	48 ¹⁾	
Continuous current 2 for $f_S = 8$ kHz	$I_{CONT2(8kHz)}$	A	68 ¹⁾	
Max. Output frequency at $f_S=4$ kHz	f_{out}	Hz	400	
Max. Output frequency at $f_S=8$ kHz	f_{out}	Hz	800	
Device power dissipation without internal continuous bleeder power for I_{CONT2}	P_V	W	960 (see page 12-1: "Power dissipation")	
Peak bleeder power DKC when $U_{ZW} = 850V$ for permissible load cycle	P_{BS}	kW	120 0.5 s on, 60 s off	
Continuous bleeder power DKC when $T_a \leq 45$ °C under max. temperature range with distance	P_{BD} ΔT d	kW K mm	1,00 100 80	
Max. energy dissipation	$W_{R,MAX}$	kWs	60	
Max. DC bus charge	W_{MAX}	kWs	60	
Internal DC bus dynamic brake (ZKS)			present	
Resistor for ZKS	R_{ZKS}	Ohm	6	
Storable energy of the DC bus capacitors	W_{ZW}	Ws	see diagrams page 4-17: "Storable energy in the bus"	
Nominal DC bus capacitance DKC	C_{ZW}	mF	1.5 \pm 20%	
DC bus voltage (dependent on mains input voltage)	U_{ZW}	V	DC 300 ... 800	
DC bus continuous power (dependent on mains input voltage)	P_{ZWD}		see diagrams page 4-28 "Allowed DC bus continuous power"	

Designation	Symbol	Unit	DKC**.3-200-7-FW
max. DC bus continuous power for a single source supply where $U_{N1} = 3 \times \text{AC } 400\text{V}$, at $T_a \leq 45 \text{ }^\circ\text{C}$	P_{ZWD}	kW	10.3
max. DC bus continuous power for a single source supply where $U_{N1} = 3 \times \text{AC } 480\text{V}$, when $T_a \leq 45 \text{ }^\circ\text{C}$	P_{ZWD}	kW	12
max. DC bus continuous power for a single source supply where $U_{N1} = 3 \times \text{AC } 400\text{V}$, plus smoothing choke and CZM01.3, at $T_a \leq 45 \text{ }^\circ\text{C}$	P_{ZWD}	kW	24
max. DC bus continuous power for a single source supply where $U_{N1} = 3 \times \text{AC } 480\text{V}$, plus smoothing choke and CZM01.3, at $T_a \leq 45 \text{ }^\circ\text{C}$	P_{ZWD}	kW	27
DC bus peak power	P_{ZWS}		see diagrams on page 4-27 "DC bus peak power"
Cooling power section and bleeder resistor			with internal blower
Cooling air flow			together for bleeder and power section
Volumetric capacity of the forced cooling		m ³ /h	approx. 150
Insulation resistance at DC500V	R_{is}	MOhm	> 25
Coupling capacitance power section against housing	C_{Kop}	nF	200

Fig. 4-7: Technical Data Mains connection and Power section

- 1) Sine threshold value
- 2) Softstart resistor is used after softstart as bleeder (R_B).
- 3) Softstart resistor is used after softstart as bleeder (R_B) and DC bus short-circuit resistor (R_{ZKS}).

Block diagram of the DKC.3-040-7-FW power section**

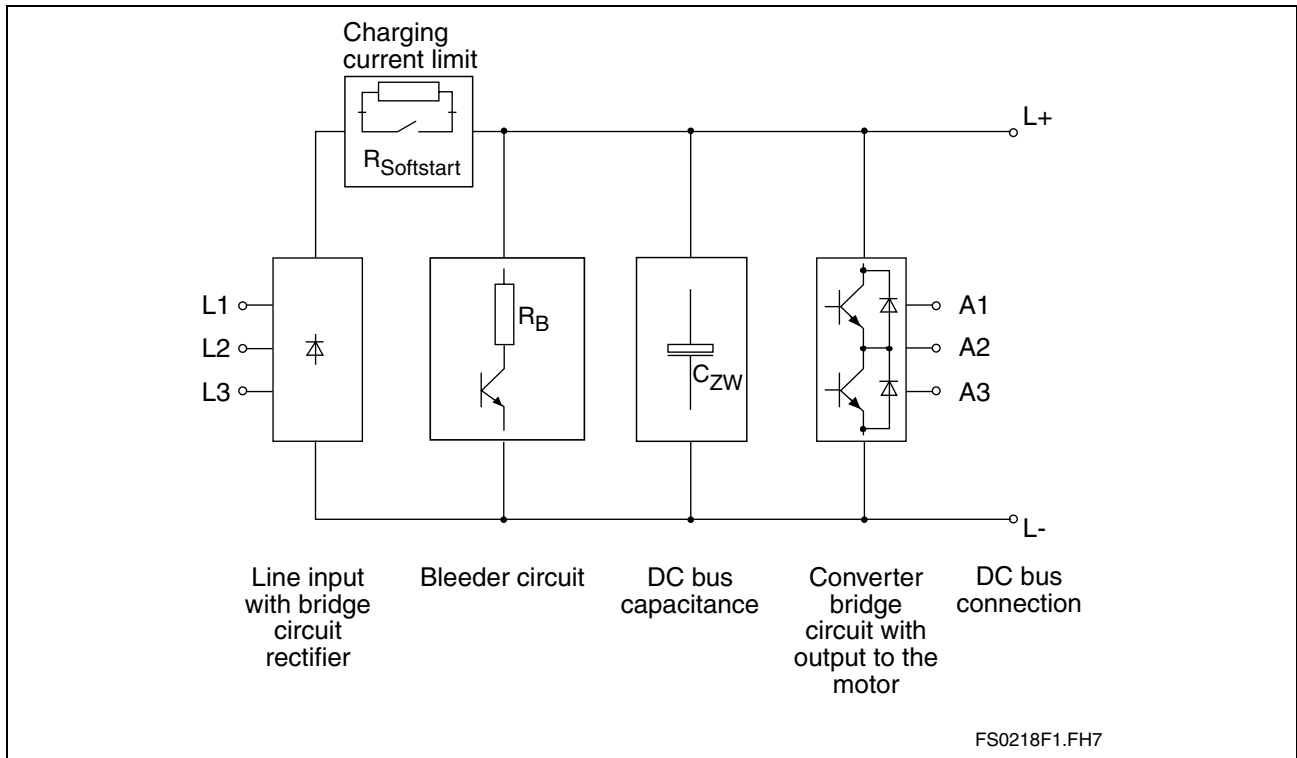

Fig. 4-8: Block diagram of the DKC**.3-040-7-FW power section

Block diagram of the DKC.3-100-7-FW power section**

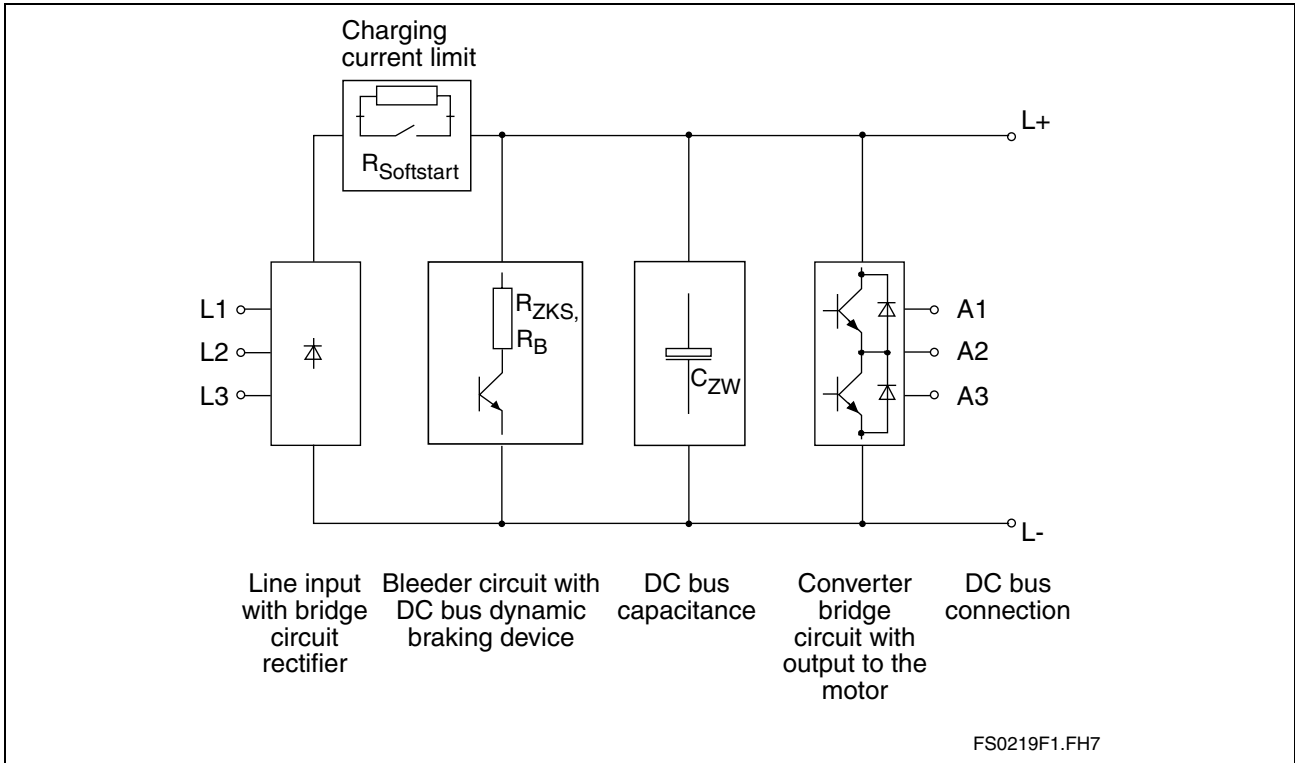

Fig. 4-9: Block diagram of the DKC**.3-100-7-FW power section

Block diagram of the DKC.3-200-7-FW power section**

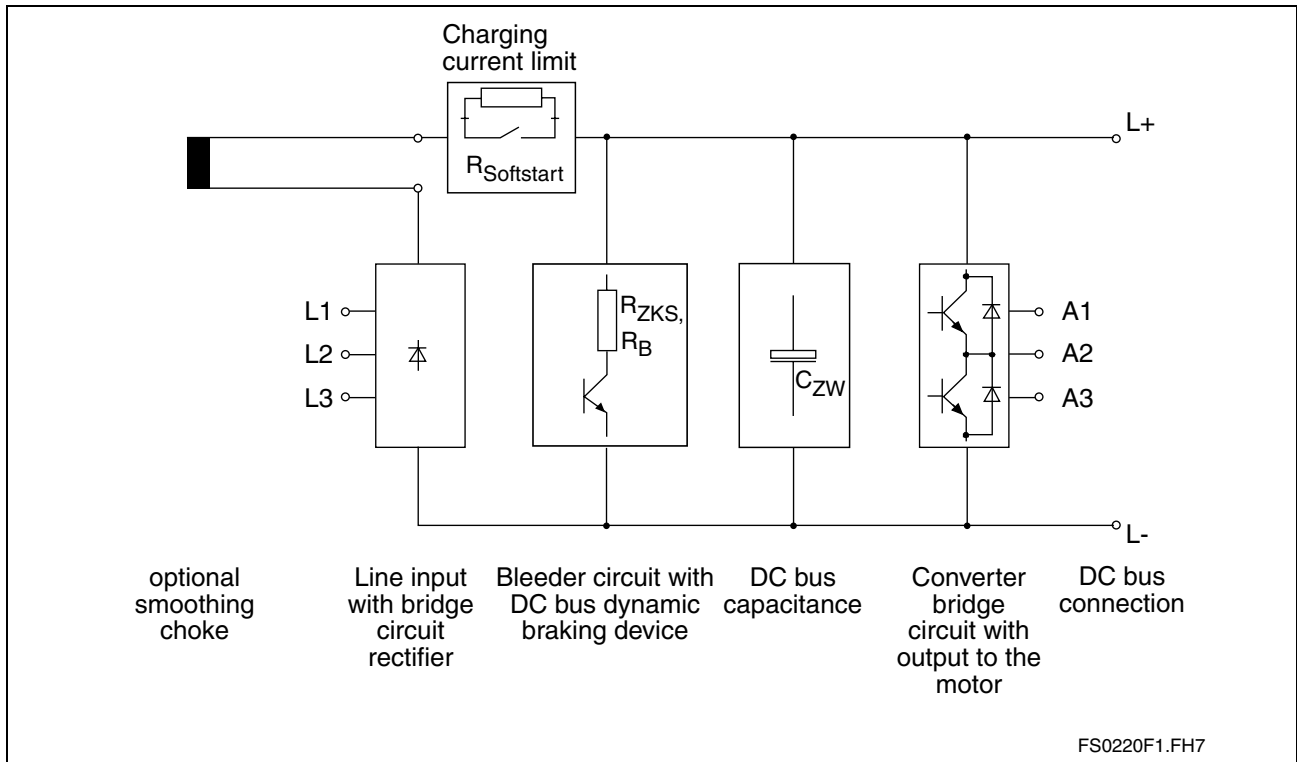

Fig. 4-10: Block diagram of the DKC**.3-200-7-FW power section

Control voltage connection for DKC

(Data applies to ambient temperature of 25 °C)

Designation	Symbol	Unit	DKC**.3-040-7-FW	DKC**.3-100-7-FW	
Control voltage	U_{N3}	V	DC (19.2 ... 28.8) V		
max. ripple effect	w		may not exceed input voltage range		
max. allowed overvoltage	U_{N3max}	V	45 V for 1 ms, non repetitive *)		
max. charging current	I_{EIN3}	A	4.0 (see diagram on page 4-16 "Output current characteristic curves for servo applications")		
max. pulse duration of I_{EIN3}	t_{N3Lade}	ms	12 (see diagram on page 4-16 "Output current characteristic curves for servo applications")		
max. input capacitance	C_{N3}	mF	0.9 * 1.2	0.9 * 1.2	
Power consumption (X1)	dependent on type of unit, without external load at control outputs and encoder interface 2				
	DKC01.3	P_{N3}	W	19	24
	DKC02.3	P_{N3}	W	19	24
	DKC03.3	P_{N3}	W	20	25
	DKC04.3	P_{N3}	W	21	26
	DKC05.3	P_{N3}	W	20	25
	DKC06.3	P_{N3}	W	20	25
	DKC11.3	P_{N3}	W	18	23
	DKC21.3	P_{N3}	W	20	25
	DKC22.3	P_{N3}	W	20	25

Fig. 4-11: Control voltage connection for DKC

Designation	Symbol	Unit	DKC**.3-200-7-FW	
Control voltage	U_{N3}	V	DC (19.2 ... 28.8) V	
max. ripple effect	w		may not exceed input voltage range	
max. allowed overvoltage	U_{N3max}	V	45 V for 1ms, non repetitive *)	
max. charging current	I_{EIN3}	A	6.0	
max. pulse duration of I_{EINmax}	t_{N3Lade}	ms	9	
max. input capacitance	C_{N3}	mF	1.0 * 1.2	
Power consumption (X1)	dependent on type of unit, without external load at control outputs and encoder interface 2			
	DKC01.3	P_{N3}	W	27
	DKC02.3	P_{N3}	W	27
	DKC03.3	P_{N3}	W	28
	DKC04.3	P_{N3}	W	29
	DKC05.3	P_{N3}	W	28
	DKC06.3	P_{N3}	W	28
	DKC11.3	P_{N3}	W	26
	DKC21.3	P_{N3}	W	28
	DKC22.3	P_{N3}	W	28

Fig. 4-12: Control voltage connection for DKC

*) To be obtained by appropriate mains sections and shielded wire routing. Connections for control voltage: see page 4-45 X1, Connections for Control voltage.

Note: Overvoltages of more than 45 V have to be derived by measures in the electrical equipment of the machine or installation. This includes:

- 24-Volt mains sections that reduce incoming overvoltages to the allowed value.
- Overvoltage limiters at the control cabinet input that limit existing overvoltages to the allowed value. This also applies to long 24-Volt lines that have been laid in parallel with power and mains cables and can absorb overvoltages caused by inductive or capacitive coupling.

Amplitude of the DKC control voltage charging current at startup, to selecting power source

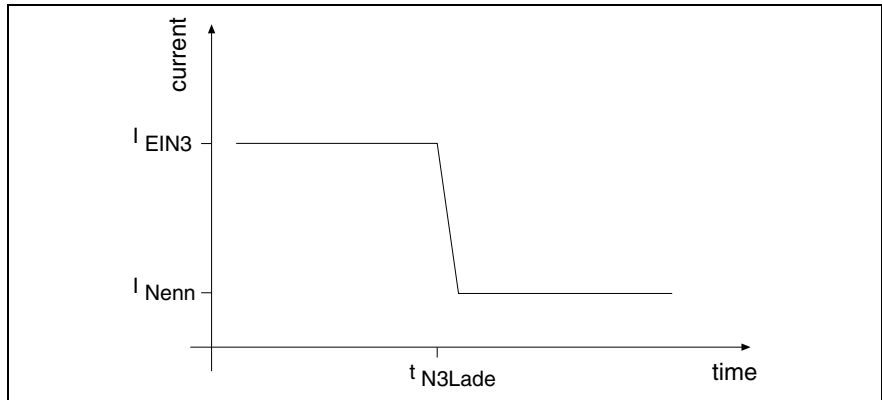

Fig. 4-13: Example of charging current inrush of control voltage

Note: For n parallel-switched inputs the charging current inrush is n-fold.

Voltage connection for holding brake

Designation	Symbol	Unit	DKC**.3-040-7-FW	DKC**.3-100-7-FW	DKC**.3-200-7-FW
Input voltage	U_{HB}	V	depends on motor type, listed in motor project planning manual (see also page 4-67 X6, Motor temperature monitoring and holding brakes)		
Ripple content	w	%			
Current consumption	I_{HB}	A			

Fig. 4-14: Voltage connection for holding brake

Materials used, Mass

Designation	Symbol	Unit	DKC**.3-040-7-FW	DKC**.3-100-7-FW	DKC**.3-200-7-FW
Mass	m	kg	5.7	9.7	19.5
materials used			Free of asbestos and silicone		

Fig. 4-15: Materials used, mass

Output current characteristic curves for servo applications (acceleration times ≤ 400 ms)

Static profile illustrated:

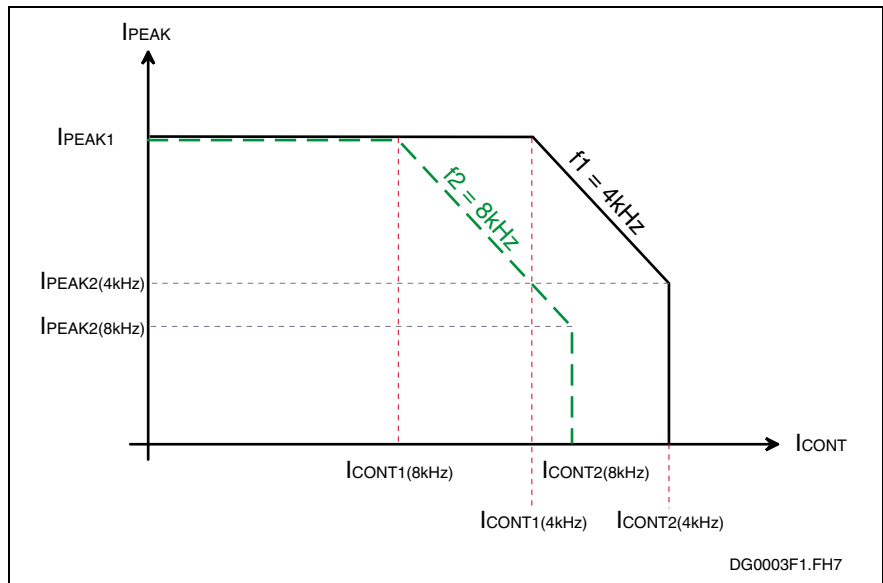

Fig. 4-16: Output current characteristic curves for servo applications

See also the table with electric data page 4-6 onward.

Storable energy in the bus

Note: The higher the connection voltage the lower the energy that can be stored in the DC bus as the differential voltage between bleeder threshold and DC bus voltage (threshold value of connecting voltage) decreases.

DKC**.3-040-7-FW

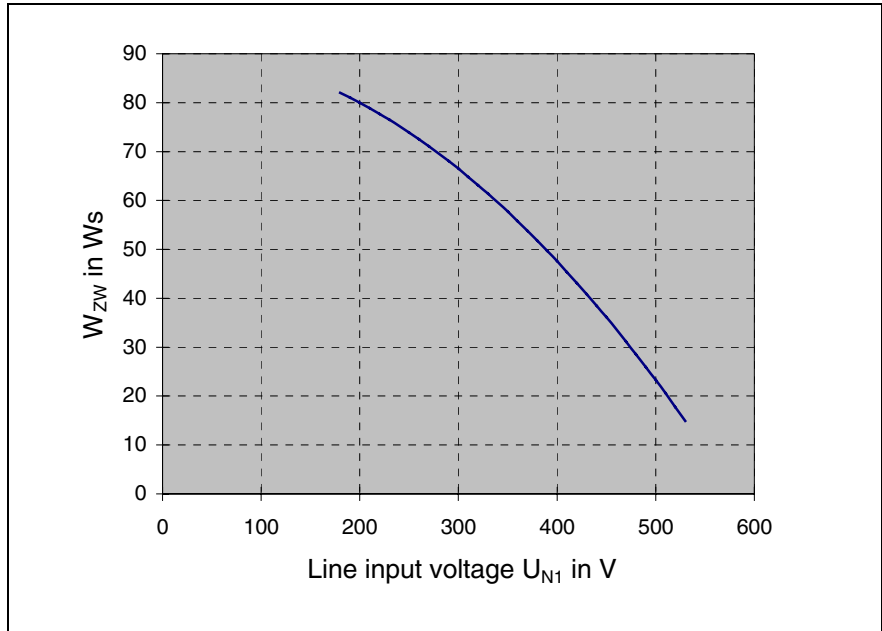

Fig. 4-17: Storable energy in the bus DKC**.3-040-7-FW

DKC**.3-100-7-FW

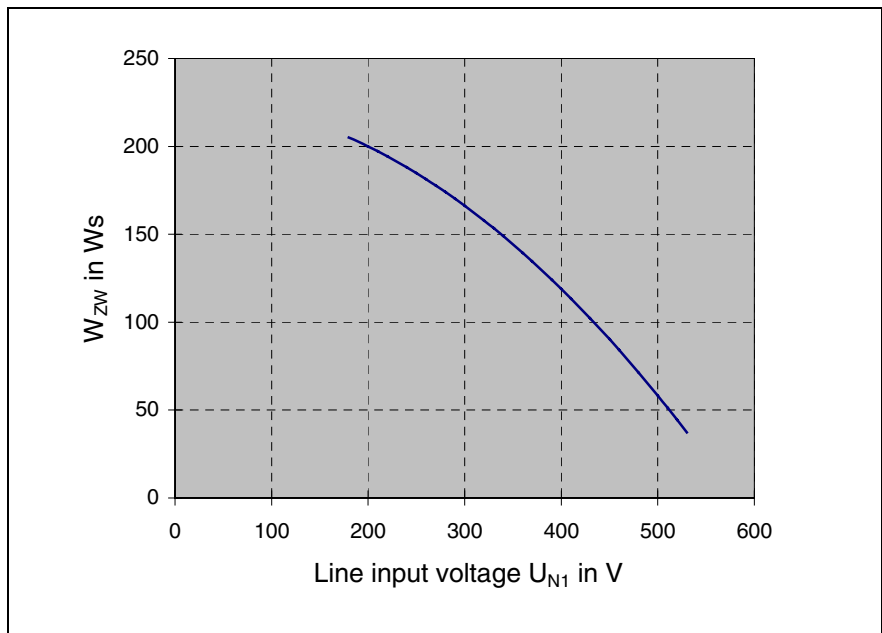

Fig. 4-18: Storable energy in the bus DKC**.3-100-7-FW

DKC**.3-200-7-FW

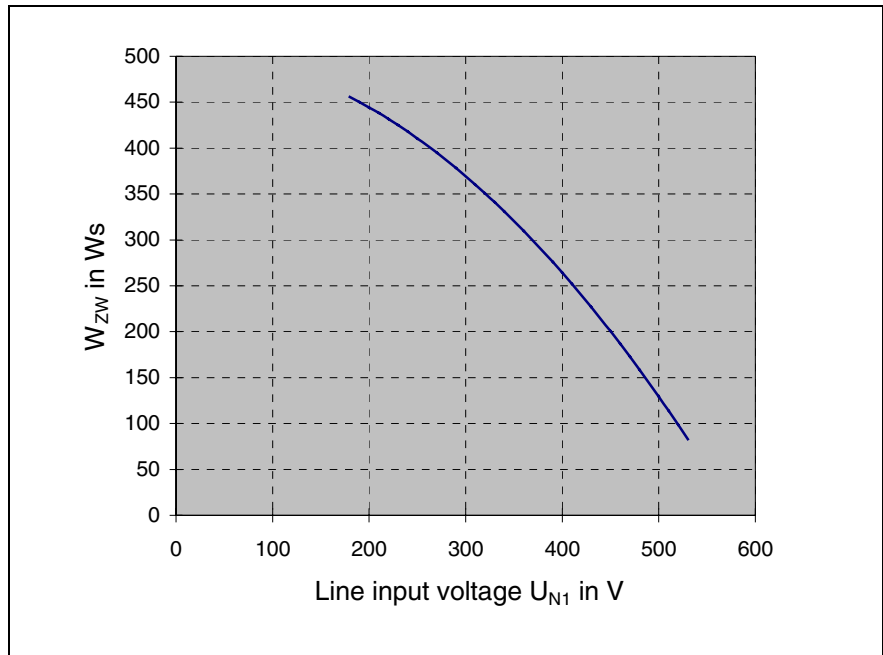

Fig. 4-19: Storable energy in the bus DKC**.3-200-7-FW

Mains supply options

Single source supply

"Single source supply" is the standard mains supply if only one DKC driver controller (or a DKC drive controller with additional components) is to be supplied with mains voltage.

Characteristic for the single source supply is that the mains voltage is applied to the DKC drive controller via individual mains connections.

Group supply

"Group supply" is the standard supply if several DKC drive controllers are to be supplied from one supply voltage.

Characteristic for the "group supply" is that the mains voltage is applied to groups of DKC drive controllers via a common mains contactor.

The group supply is divided into:

- "group supply with DC bus connection" and
- "group supply without DC bus connection"

Both supply options have their advantages for various demands.

See page 4-21 "Selection criteria for supply options".

Central supply

A "central supply" is one where several DKC drive controllers are provided with power via a common DC bus from only one DKC drive controller.

Characteristic for the "central supply" is the central power supply through the DKC drive controller that is connected over a single mains contactor to the mains voltage.

Note on central supply

The "central supply" option is connected at the single phase/three phase input with the DKC that has the highest current type.

Note: The connection of the devices DKC**.3-100 and DKC**.3-200 to the mains power is to protect the integrated DC bus dynamic brake (ZKS).

See also "Fig. 4-146: Block diagram interlock ZKS/Mains"

Number of ECODRIVE03 Units and Auxiliary Components on one DC bus

Note: The total number of units with bleeder set up on one DC bus should not exceed **max. 12**. Up to this number combinations as shown below are possible.

	Max. number ECODRIVE components on one DC bus (including supplying unit)				
	DKC**.3-200	DKC**.3-100	DKC**.3-040	BZM01.3-01	CZM01.3-02
Central supply via DKC**.3-200	3	8	11	4	2
Central supply via DKC**.3-200 with GLD 12	3	8	11	4	4
Central supply via DKC**.3-100	0 (not allowed)	3	6	2	2
Group supply with DC bus connection DKC**.3-040	0 (not allowed)	0 (not allowed)	12	2	1

Fig. 4-20: Max. number of ECODRIVE03 components on one DC bus

Example: Central supply via DKC**.3-200 with GLD 12:

- 3 * DKC**.3-200
- 4 * DKC**.3-100
- 3 * DKC**.3-040
- 1 * BZM01.3-01
- 3 * CZM01.3-02

Sum of ECODRIVE03 components with bleeder: 12

Sum of all ECODRIVE03 components: 15

Drive controllers with higher rated current can be replaced by drive controllers with lower rated current.

Example for central supply via DKC**.3-100 (see table above):

(3 x DKC**.3-100) + (6 x DKC**.3-040) can be replaced by (9 x DKC**.3-40).

Selection criteria for supply options

Selection criteria for "Mains supply options."	Mains supply options			
	Single source supply	Group supply without DC bus connection	Group supply with DC bus connection	Central supply
only 40 A units	X	X	X	
only 100 A units	X	X		X
only 200 A units	X	X		X
Units with different current types	X	X		X (via unit with highest current type)
largest possible continuous bleeder output			X	X
largest possible peak bleeder output			X	X
largest possible regenerative power			X	X
largest possible DC bus output	X	X ¹⁾		
least possible installation resources (space, wiring, fuse protection)				X
highest level of availability of the drive package in case of error	X			
smallest possible charging current inrush				X
fastest possible DC bus charging		X ²⁾	X ³⁾	

Fig. 4-21: Selection criteria for supply options

- 1) Limited to the specifications of the used tripping circuit breaker.
- 2) No power flux of high power drives onto those with low power flux.
- 3) All participating discharge units (self or ZKS-discharging) operate parallel.

Arranging the Single source supply

Note: DC bus connection of drive controllers that are connected to the mains via separate contactors is not allowed!

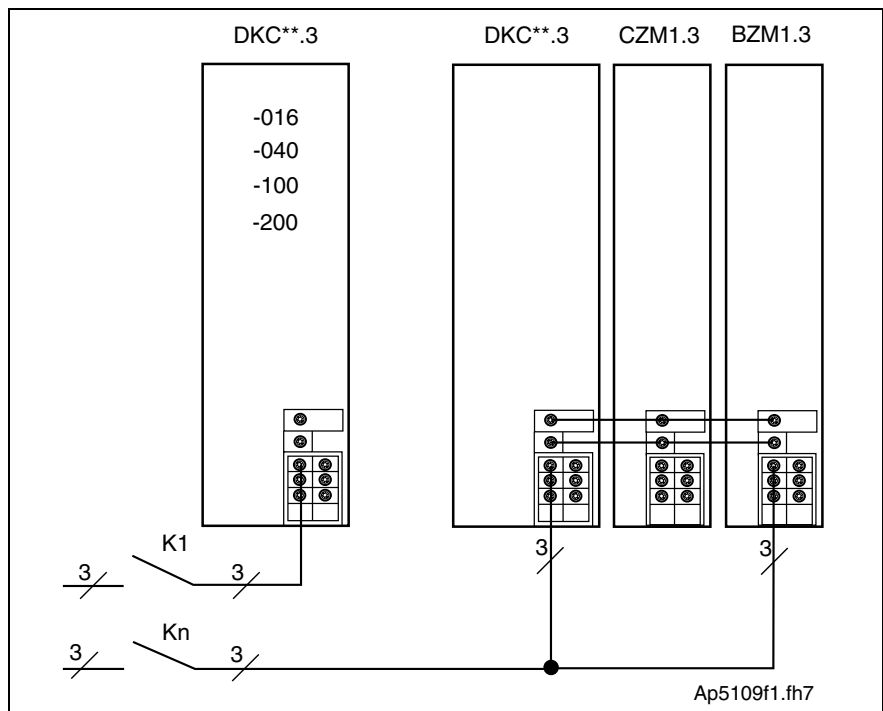

Fig. 4-22: Single source supply

Note: In addition to the illustrated connections of the BZM01.3 at the DC bus, the following connections must be wired as well:

- Bb contact
- control voltage supply

Arranging the Group supply without DC bus connection

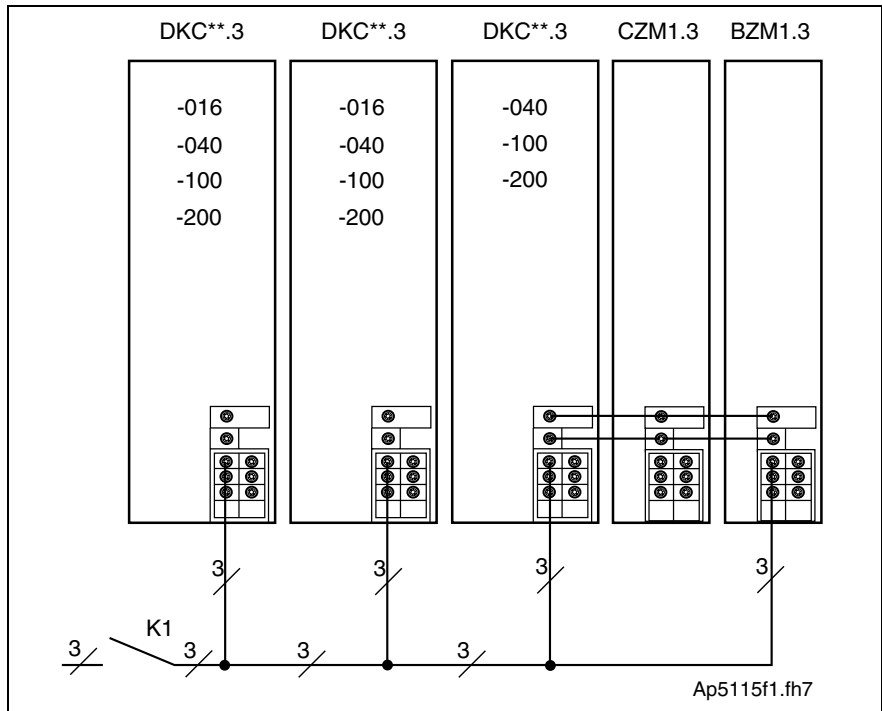

Fig. 4-23: Group supply without DC bus connection

Note: In addition to the illustrated connections of the BZM01.3 at the DC bus, the following connections must be wired as well:

- Bb contact
- control voltage supply

Arranging the Group supply with DC bus connection

Note: Increase the available continuous power in the common DC bus for the devices DKC**.3-040.

See also page 16-5 Calculating the allowed continuous braking resistor and DC bus power.

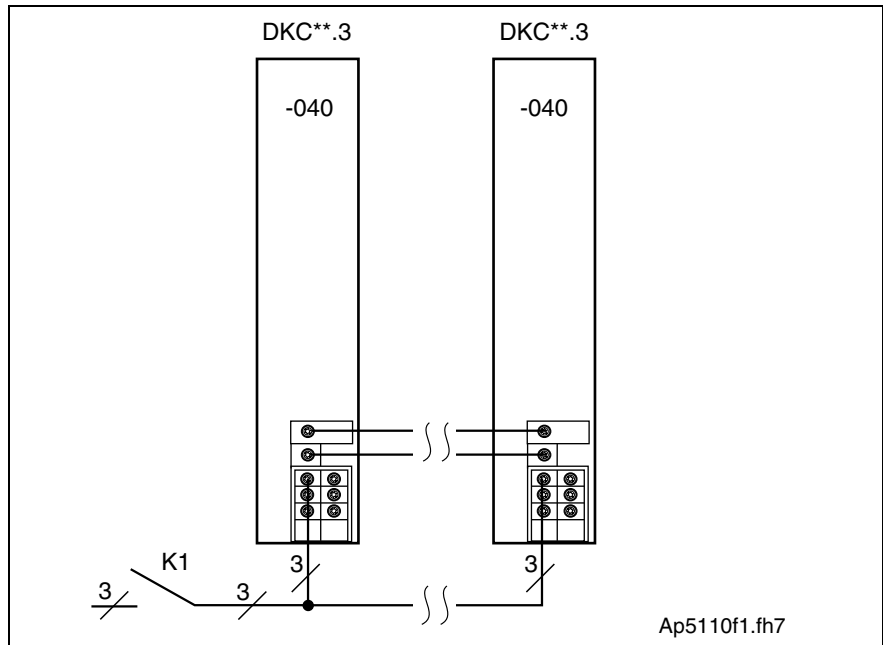

Fig. 4-24: Group supply with DC bus connection

Note: In addition to the illustrated connections of the drive controller at the DC bus, the following connections must be wired as well:

- Bb contact
- control voltage supply

Arranging the Central supply

Note: DKC**.3-040 as supply unit in "Central supply" not allowed!

Note: The connection of the devices DKC**.3-100 and DKC**.3-200 to the mains power is not to increase the allowed DC bus continuous power but to protect the integrated DC bus dynamic brake setup (ZKS).

See also "Fig. 4-146: Block diagram interlock ZKS/Mains"

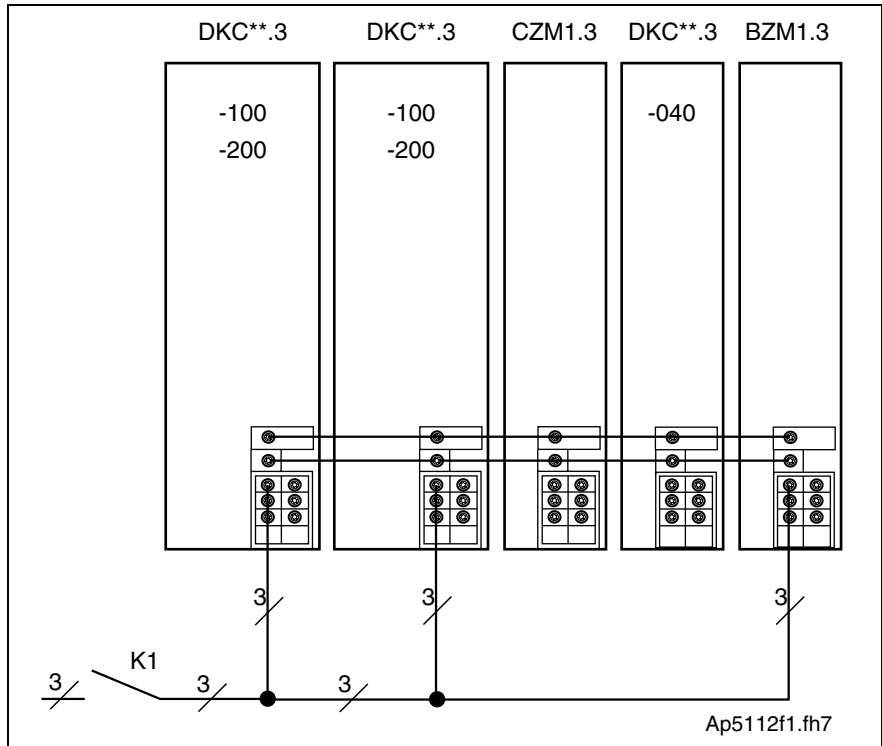

Fig. 4-25: Central supply

Note: In addition to the illustrated connections of the drive controller at the DC bus, the following connections must be wired as well:

- Bb contact
- control voltage supply
- Ud and Udpower supply (see "Fig. 4-149: UD power supply")

Energy circuit DKC**.3 using "Central supply" as an example

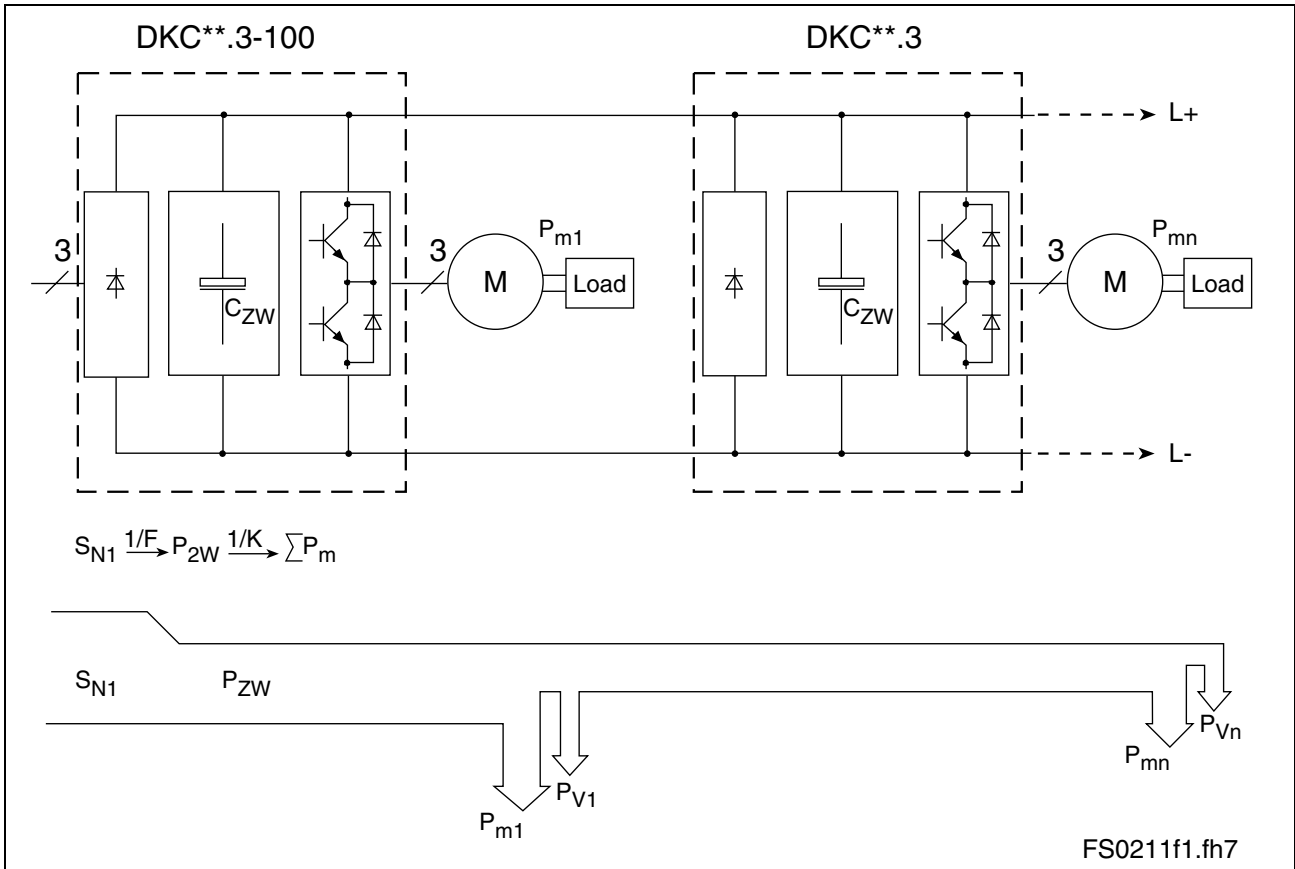

Fig. 4-26: Energy circuit DKC**.3 using "Central supply" as an example

Allowed DC bus Peak Power

Note: Diagrams apply to single and central supply!

DKC.3-040-7-FW**

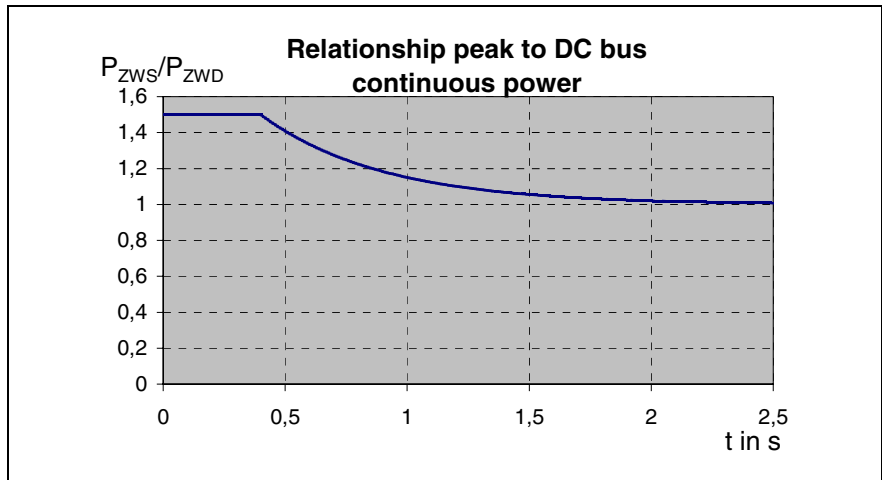

Fig. 4-27: Allowed peak power in DC bus of DKC**.3-040-7-FW

DKC**.3-040-7-FWs are not suited for drive applications if the required intermittent operating power of the unit's nominal power exceeds 50%!

DKC.3-100-7-FW**

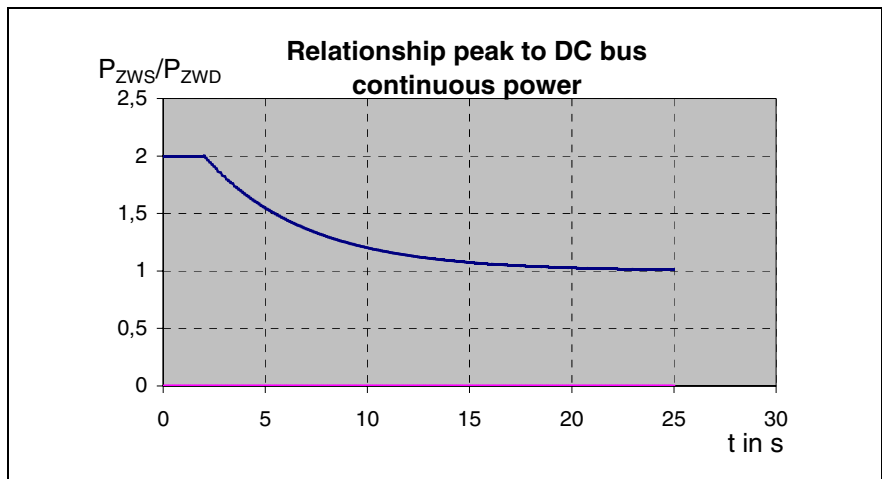

Fig. 4-28: Allowed peak power in DC bus of DKC**.3-100-7-FW

DKC.3-200-7-FW**

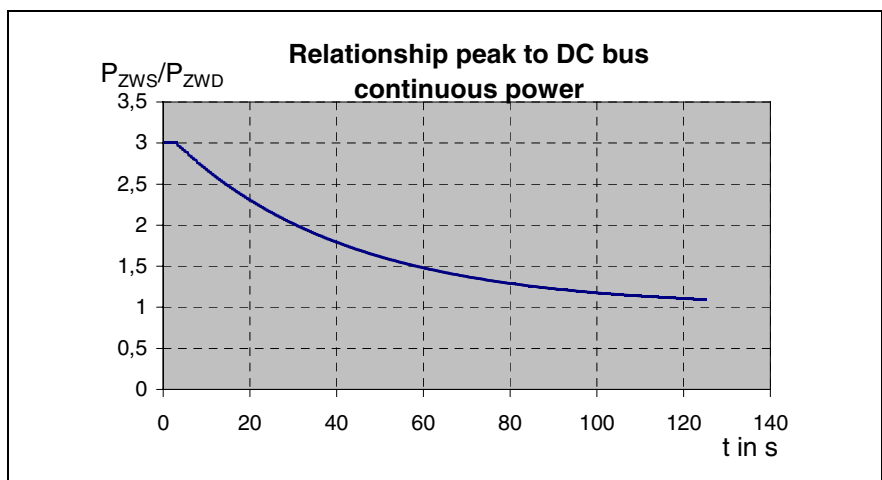

Fig. 4-29: Allowed peak power in DC bus of DKC**.3-200-7-FW

Allowed DC bus continuous power without auxiliary components

DKC**.3-040-7 in "Single source supply":

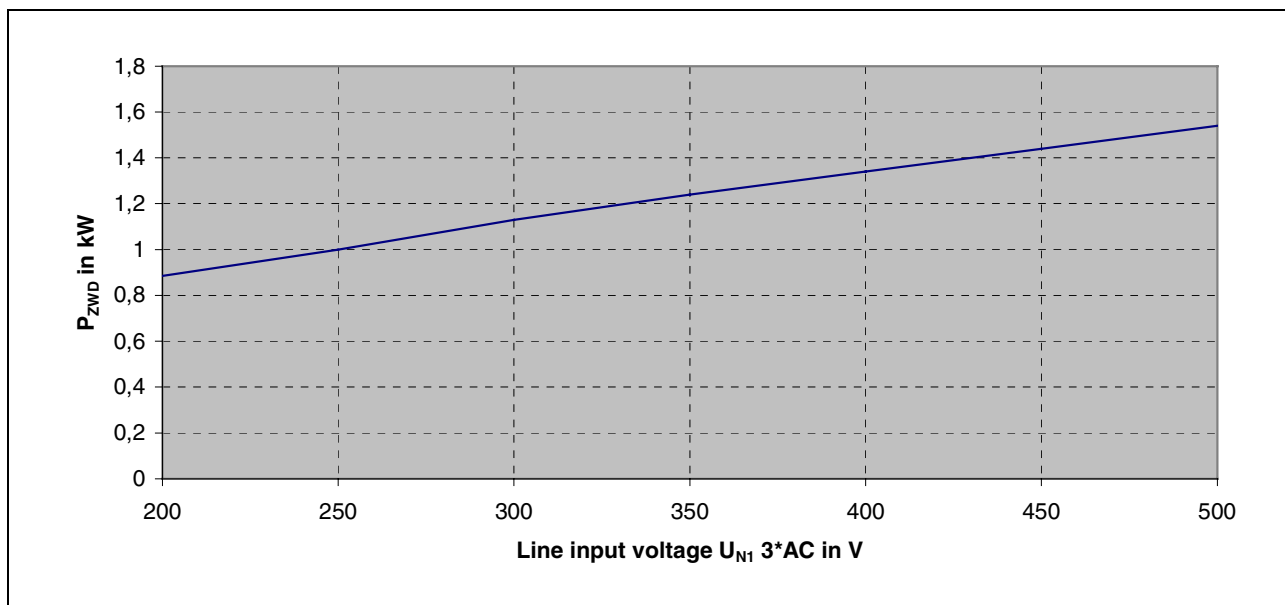

Fig. 4-30: Allowed DC bus continuous power for Single source supply DKC**.3-040-7

DKC**.3-040-7 in "Group supply without DC bus connection":

No increase in the allowed continuous power rating!

See page 4-23: "Arranging the Group supply without DC bus connection"

DKC**.3-040-7 in "Group supply with DC bus connection":

Further DKC**.3-040-7 devices on the common DC-bus increase the available continuous power. The increase can be seen in the diagram "Fig. 4-30: Allowed DC bus continuous power for Single source supply DKC**.3-040-7". It represents 80% of the value indicated.

DKC**.3-040-7 in "Central supply":

DKC**.3-040-7 as supply in "central supply" not allowed !

Note: Definition of terms, see page 4-19: "Mains supply options".

DKC.3-100-7 in "Single source supply":**

Fig. 4-31: Allowed DC bus continuous power for Single source supply
DKC**.3-100-7

DKC.3-100-7 in "Group supply without DC bus connection":**

No increase in the allowed continuous power!

See page 4-23: "Arranging the Group supply without DC bus connection"

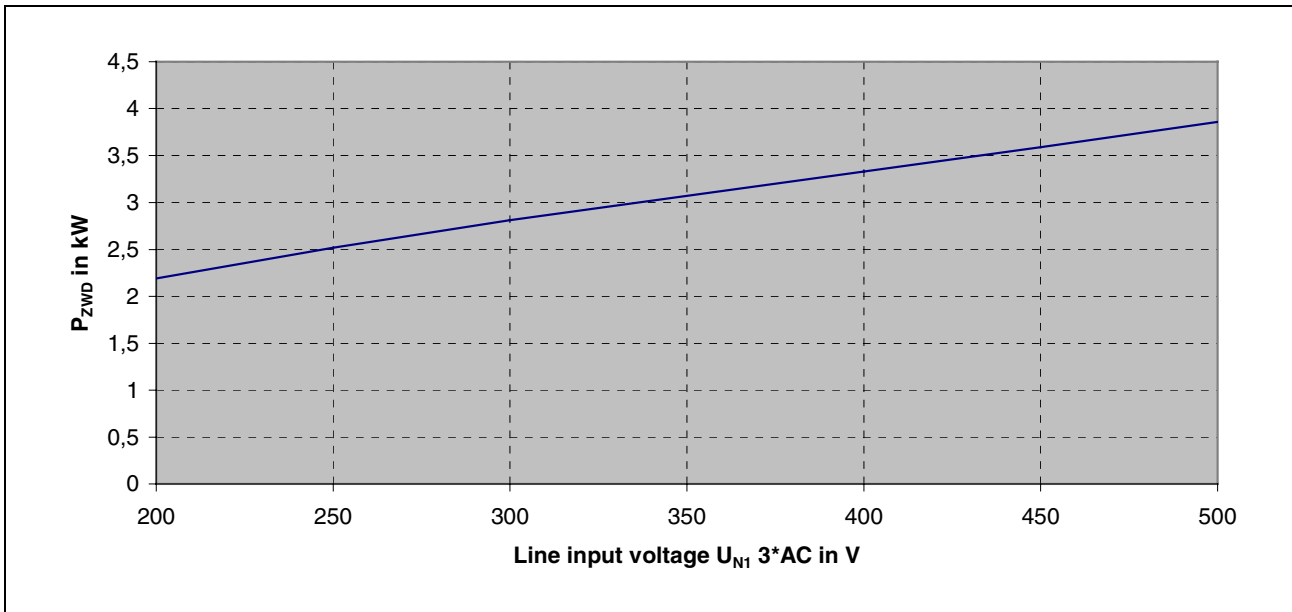
DKC.3-100-7 in "Group supply with DC bus connection":**

See "DKC**.3-100-7 in "Central supply":"

DKC.3-100-7 in "Central supply":**

Further DKC**.3-***-7 devices on the common DC-bus increase the sum of the available continuous power. The increase can be seen in the diagram "DKC**.3-***-7 in Single source supply" of each particular device.

The sum of the allowed DC bus continuous power is limited to the performance specifications of the DKC**.3-100-7 with CZM 01.3 in single source supply.

Note: Definition of terms, see page 4-19: "Mains supply options".

DKC.3-200-7 in "Single source supply":**

Fig. 4-32: Allowed DC bus continuous power for Single source supply DKC**.3-200-7

DKC.3-200-7 in "Group supply without DC bus connection":**

No increase in the allowed continuous power!

See page 4-23: "Arranging the Group supply without DC bus connection"

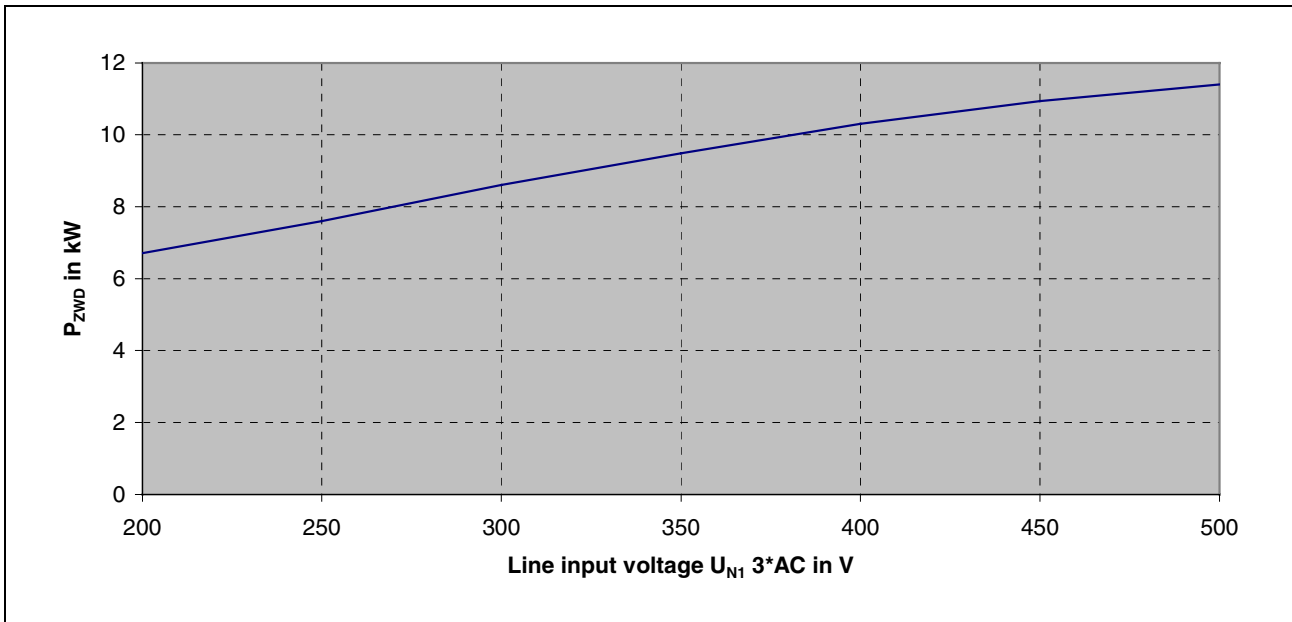
DKC.3-200-7 in "Group supply with DC bus connection":**

See "DKC**.3-200-7 in "Central supply":"

DKC.3-200-7 in "Central supply":**

Further DKC**.3-***-7 devices on the common DC-bus increase the sum of the available continuous power. The increase can be seen in the diagram "DKC**.3-***-7 in Single source supply" of each particular device. The sum of the allowed DC bus continuous power is limited to the performance specifications of the DKC**.3-200-7 with CZM 01.3 in single source supply.

Note: Definition of terms, see page 4-19: "Mains supply options".

Allowed DC bus continuous power with CZM01.3 auxiliary components

Note: The allowed DC bus continuous power of the drive controllers is increased by adding components.

- CZM01.3 reduces the load of the DC bus capacitor in drive controllers.
-

DKC.3-040-7 with CZM01.3 in "Single source supply":**

No increase in the allowed continuous power!

DKC.3-040-7 with CZM01.3 in "Group supply without DC bus connection":**

No increase in the allowed continuous power!

See page 4-23: "Arranging the Group supply without DC bus connection"

DKC.3-040-7 with CZM01.3 in "Group supply with DC bus connection":**

No increase in the allowed continuous power!

DKC.3-040-7 with CZM01.3 in "Central supply":**

DKC**.3-040-7 as supply in „central supply“ not allowed!

Note: Definition of terms, see page 4-19: "Mains supply options".

DKC.3-100-7 with CZM01.3 in "Single source supply":**

Fig. 4-33: Allowed DC bus continuous power for Single source supply
DKC**.3-100-7 with CZM01.3

DKC.3-100-7 with CZM01.3 in "Group supply without DC bus connection":**

No increase in the allowed continuous power!

See page 4-23: "Arranging the Group supply without DC bus connection"

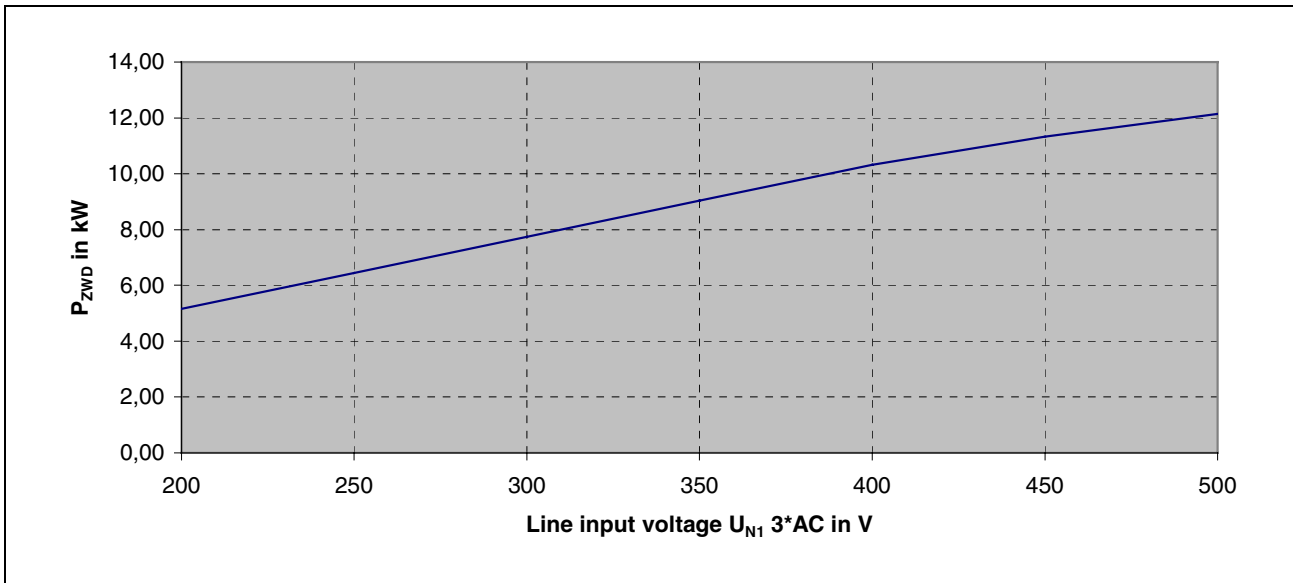
DKC.3-100-7 with CZM01.3 in "Group supply with DC bus connection":**

See "DKC**.3-100-7 with CZM01.3 in "Central supply":"

DKC.3-100-7 with CZM01.3 in "Central supply":**

Further DKC**.3-***-7 devices on the common DC-bus increase the sum of the available continuous power. The increase can be seen in the diagram "DKC**.3-***-7 in Single source supply" of each particular device.

The sum of the allowed DC bus continuous power is limited to the performance specifications of the DKC**.3-100-7 with CZM 01.3 in Single source supply.

Note: Definition of terms, see page 4-19: "Mains supply options".

DKC.3-200-7 with CZM01.3 in "Single source supply":**

Fig. 4-34: Allowed DC bus continuous power for Single source supply
DKC**.3-200-7 with CZM01.3

DKC.3-200-7 with CZM01.3 in "Group supply without DC bus connection":**

No increase in the allowed continuous power!

See page 4-23: "Arranging the Group supply without DC bus connection"

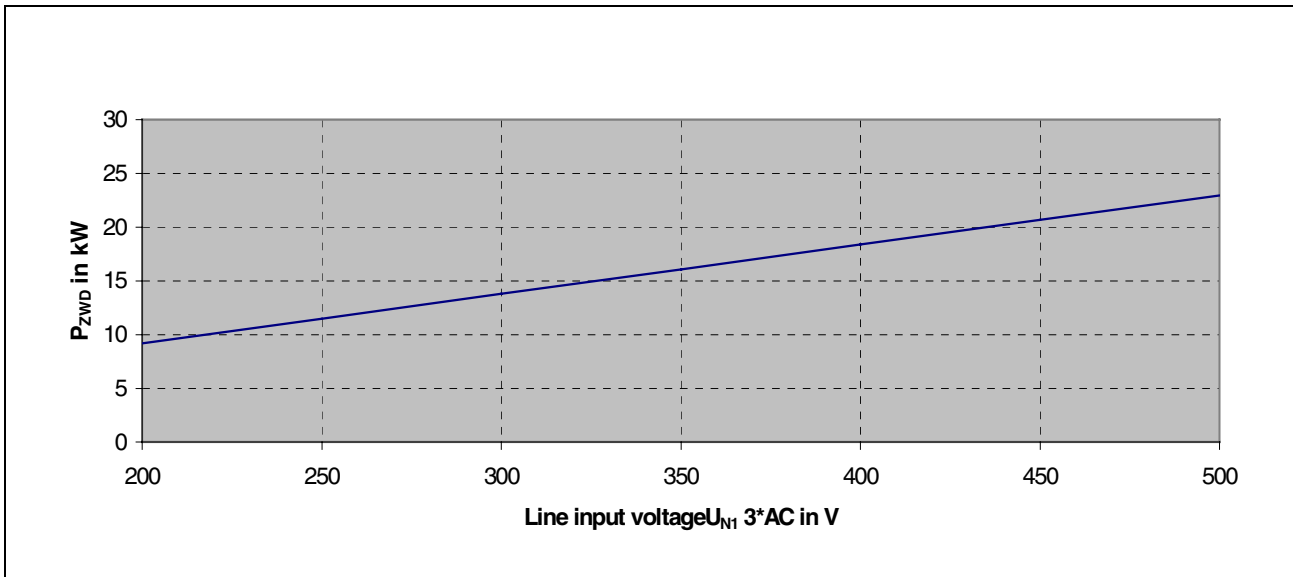
DKC.3-200-7 with CZM01.3 in "Group supply with DC bus connection":**

See "DKC**.3-200-7 with CZM01.3 in "Central supply":"

DKC.3-200-7 with CZM01.3 in "Central supply":**

Further DKC**.3-***-7 devices on the common DC-bus increase the sum of the available continuous power. The increase can be seen in the diagram "DKC**.3-***-7 in Single source supply" of each particular device. The sum of the allowed DC bus continuous power is limited to the performance specifications of the DKC**.3-200-7 with CZM 01.3 in Single source supply.

Note: Definition of terms, see page 4-19: "Mains supply options".

Allowed DC bus continuous power with CZM01.3 and GLD12 smoothing choke

-
- Note:** The allowed DC bus continuous power of a DKC is increased by adding components.
- CZM01.3 reduces the load on the DC bus capacitor in DKCs.
 - GLD 12 improves form factor of the connected load and thus the DC bus capacitor load in DKCs (possible with DKC**.3-200-7).
-

DKC.3-200-7 with CZM01.3 and filter choke GLD12 in "Single source supply":**

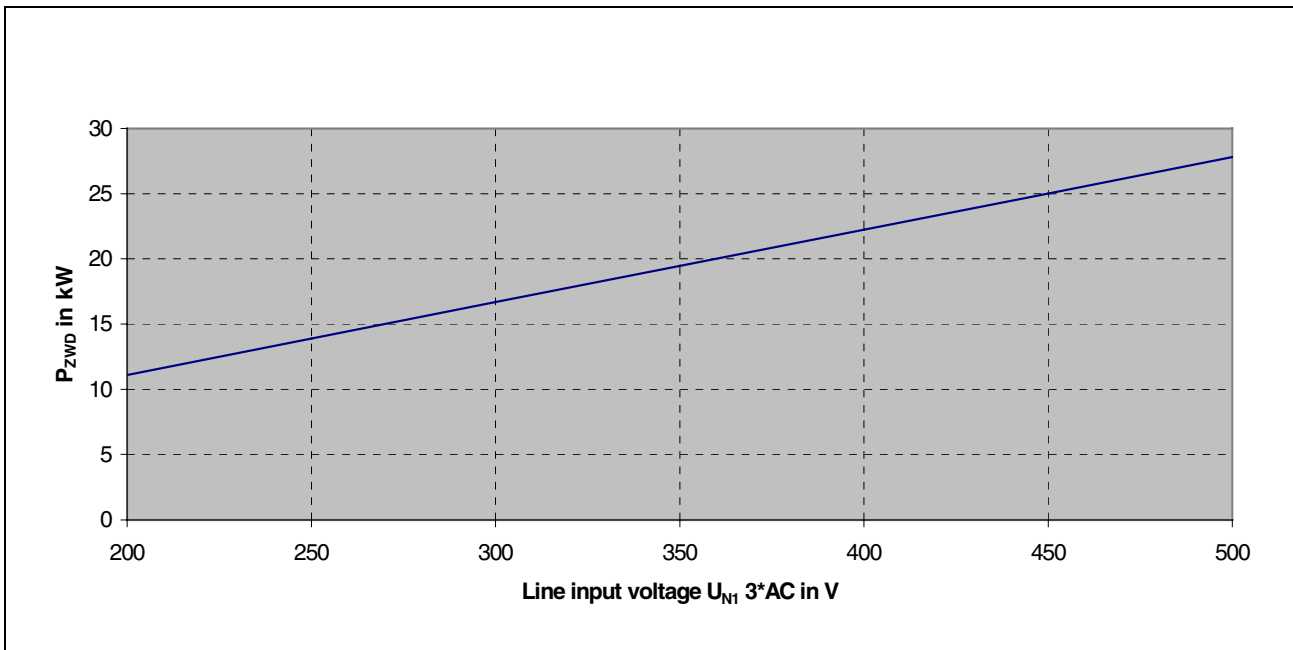

Fig. 4-35: Allowed DC bus continuous power for single source supply DKC**.3-200-7 with CZM01.3 and filter choke GLD12

DKC.3-200-7 with CZM01.3 and filter choke GLD12 in "Group supply without DC bus connection":**

No increase in the allowed continuous power!

See page 4-23: "Arranging the Group supply without DC bus connection"

DKC.3-200-7 with CZM01.3 and filter choke GLD12 in "Group supply with DC bus connection":**

See "DKC**.3-200-7 with CZM01.3 and filter choke GLD12 in "Central supply":"

DKC.3-200-7 with CZM01.3 and filter choke GLD12 in "Central supply":**

Further DKC**.3-***-7 devices on the common DC-bus increase the sum of the available continuous power. The increase can be seen in the diagram "DKC**.3-***-7 in Single source supply" of each particular device. The sum of the allowed DC bus continuous power is limited to the performance specifications of the DKC**.3-200-7 with CZM 01.3and filter choke GLD12 in Single source supply.

Note: Definition of terms, see page 4-19: "Mains supply options".

Allowed DC bus continuous power with single-phase mains connection

The operation of a single-phase mains supply reduces the allowed DC bus continuous power as per the following diagram.

Note: The single-phase mains connection is only permitted with single source supply!

With single-phase operation peak power in the DC bus is the same as continuous power.

Allowed DC bus continuous power in single-phase mode at supply networks with a frequency of 50 Hz

DKC**.3-040-7, DKC**.3-100-7

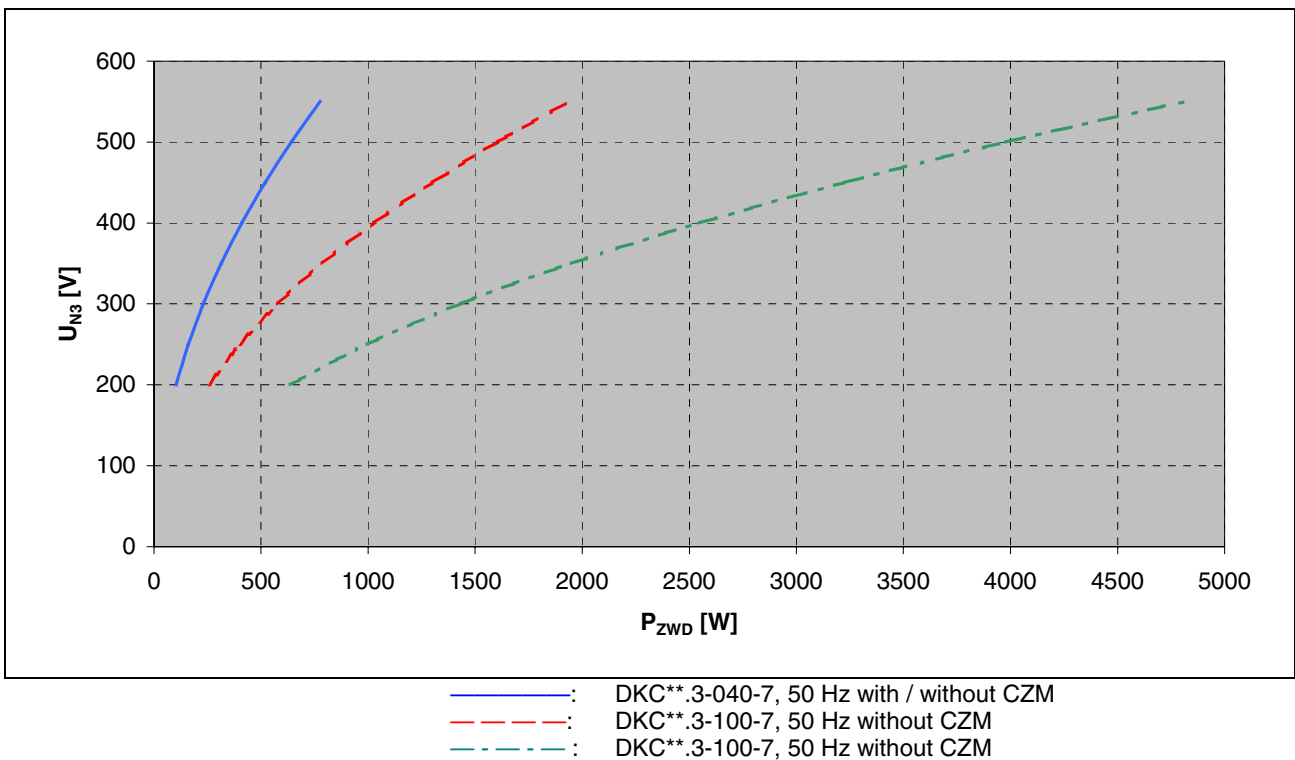
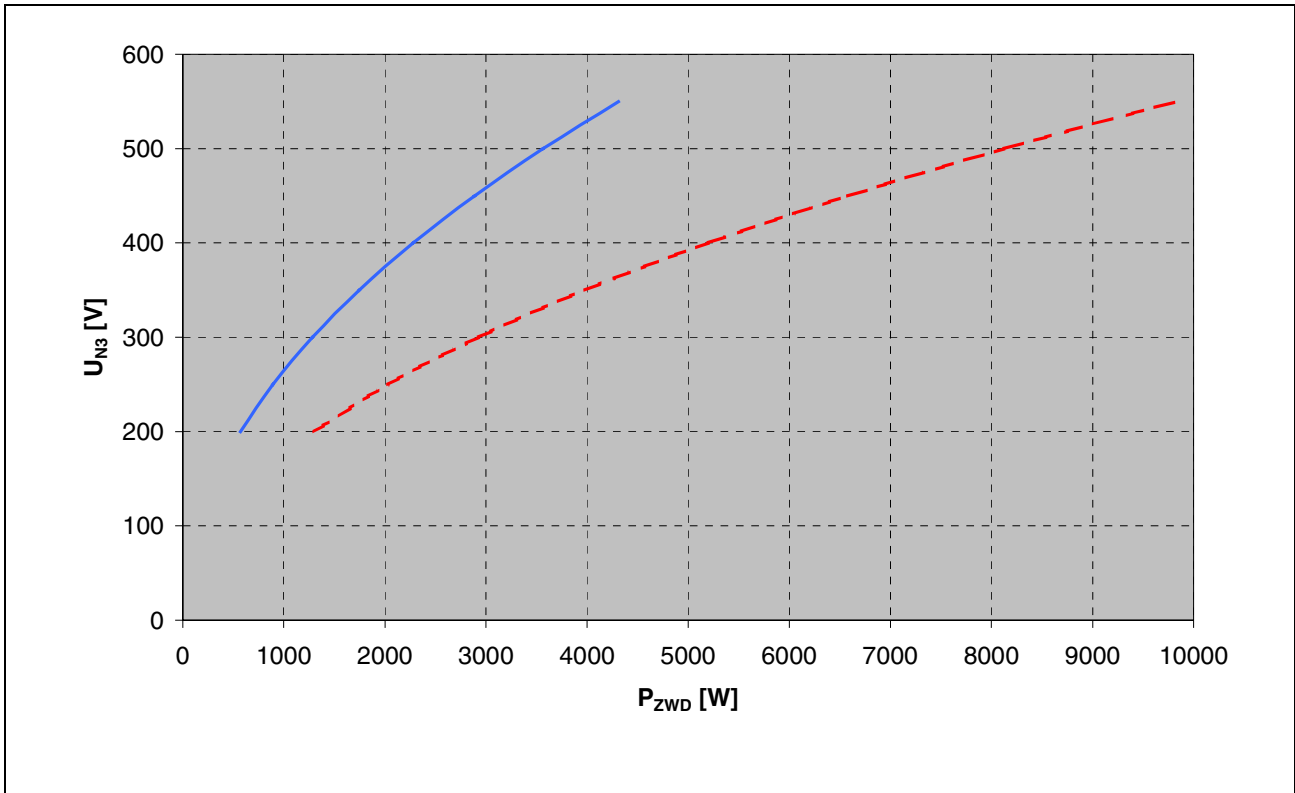

Fig. 4-36: Allowed DC bus continuous power in single-phase mode with 50 Hz

DKC**.3-200-7



- : DKC**.3-200-7, 50 Hz without CZM
- - -: DKC**.3-200-7, 50 Hz with CZM

Fig. 4-37: Allowed DC bus continuous power in single-phase mode with 50 Hz

Allowed DC bus continuous power in single-phase mode with networks with a frequency of 60 Hz

DKC**.3-040-7, DKC**.3-100-7

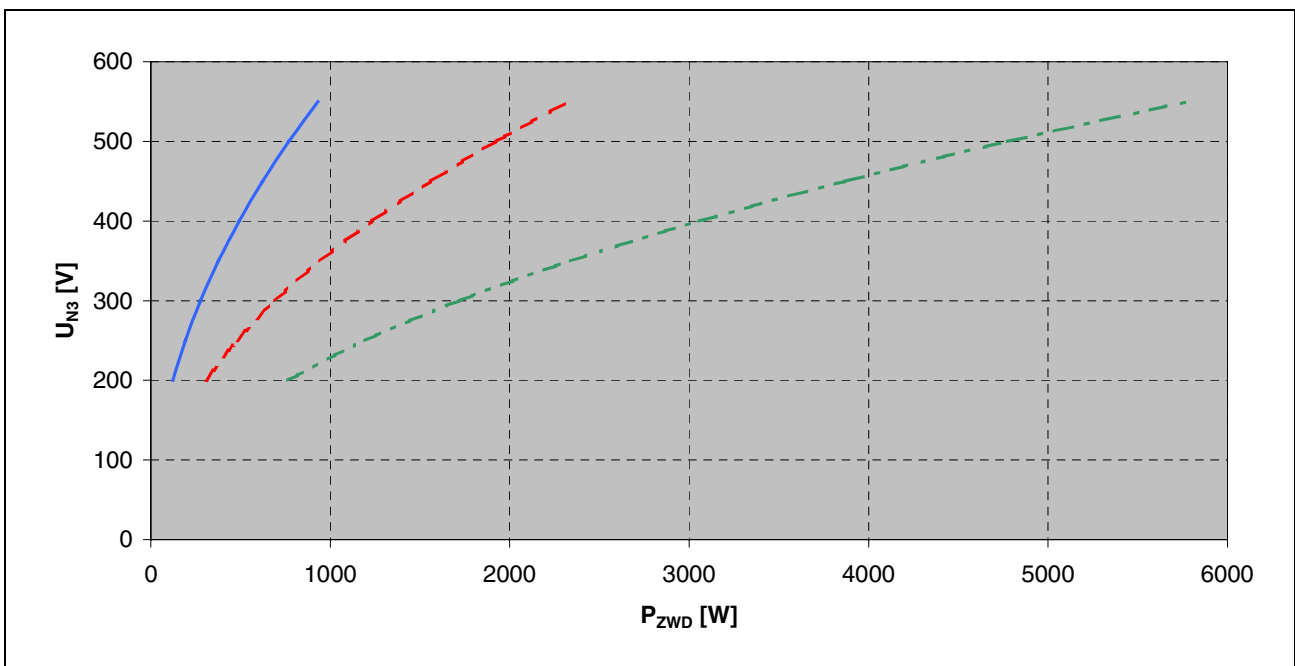

- : DKC**.3-040-7, 60 Hz with / without CZM
- - -: DKC**.3-100-7, 60 Hz without CZM
- · - ·: DKC**.3-100-7, 60 Hz without CZM

Fig. 4-38: DC bus continuous power in single-phase mode with 60 Hz

DKC**.3-200-7

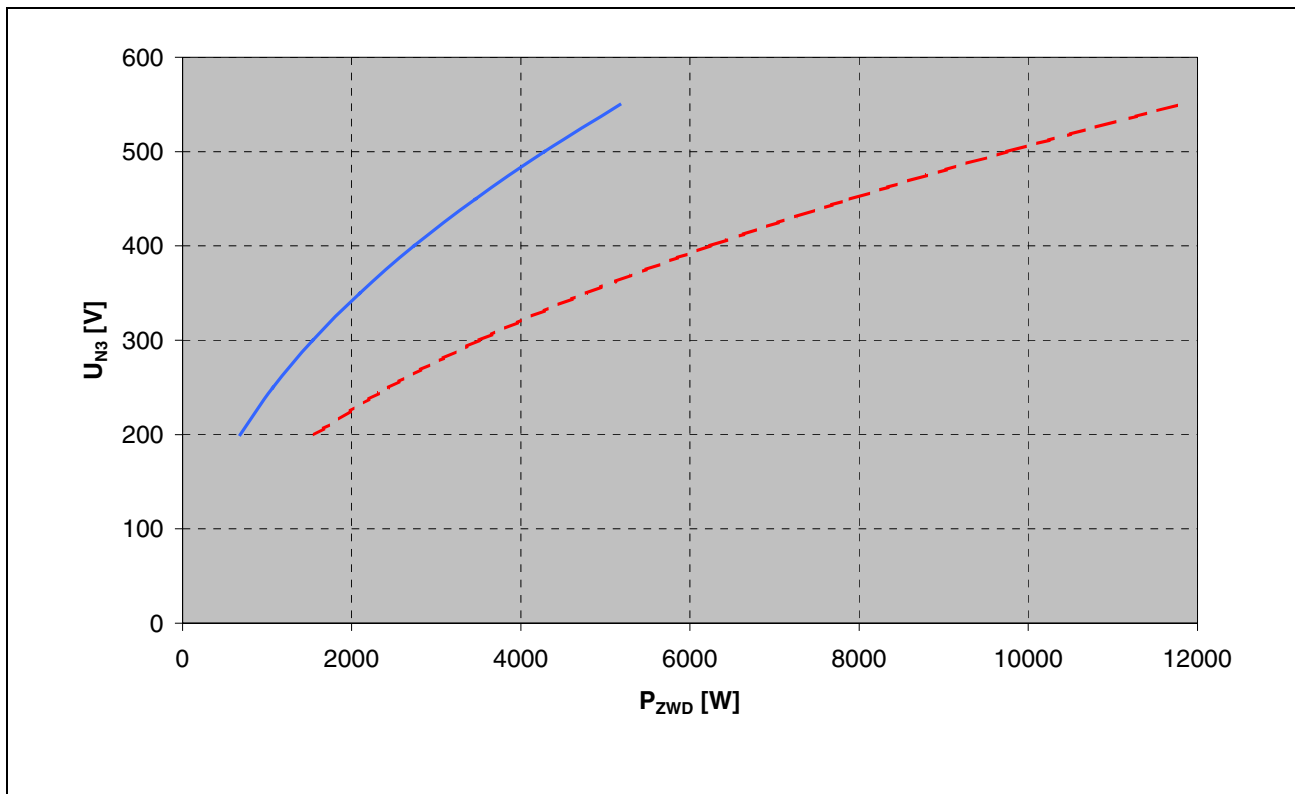

—: DKC**.3-200-7, 60 Hz without CZM

- - -: DKC**.3-200-7, 60 Hz with CZM

Fig. 4-39: DC bus continuous power in single-phase mode with 60 Hz

Note: Do not operate DKC**.3-200-7s with single-phase mains with smoothing choke !

CE label, C-UL listing, Tests

CE label:

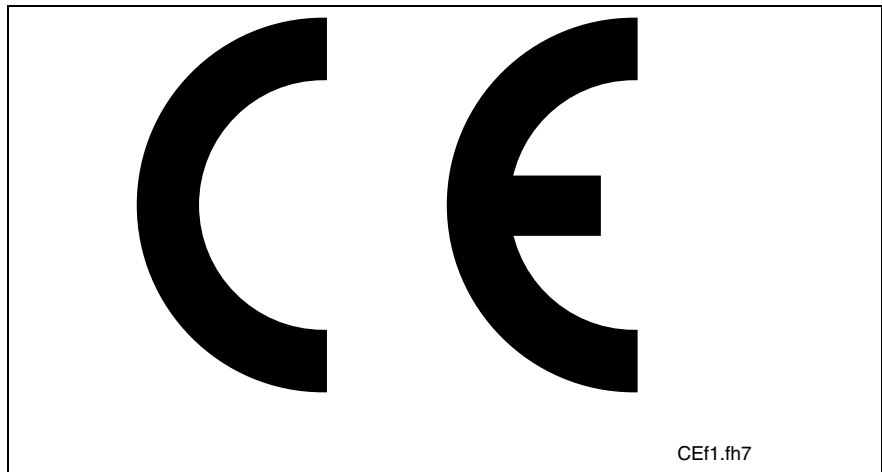

Fig. 4-40: CE label

C-UL listing: • Per UL508 C under file no. E134201.

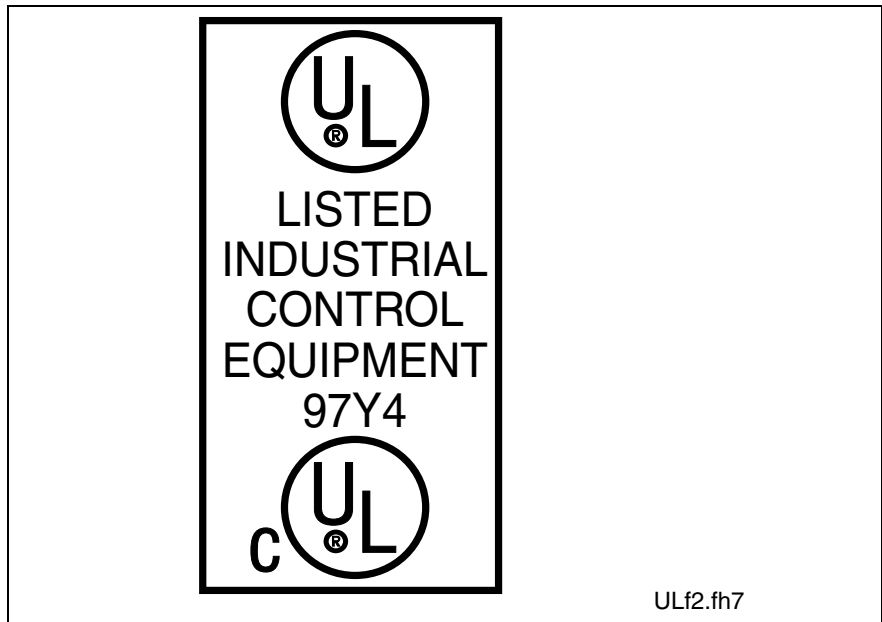

Fig. 4-41: C-UL listing

DKC**.3-040-7s and DKC**.3-100-7s are C-UL listed.

Tests:

High-voltage test according to EN50178	Routine test with DC2100 V	1 s
Insulation test according to EN50178	Routine test with DC500 V	1 s
Separation between the electrical circuits of the control and high voltage power	safe separation according to EN50178	
Clearances and creepage distances	according to EN50178	

Fig. 4-42: Tests

4.2 Electrical connections - independent of the drive controller type

A look at the drive controller and connector designations

Front view

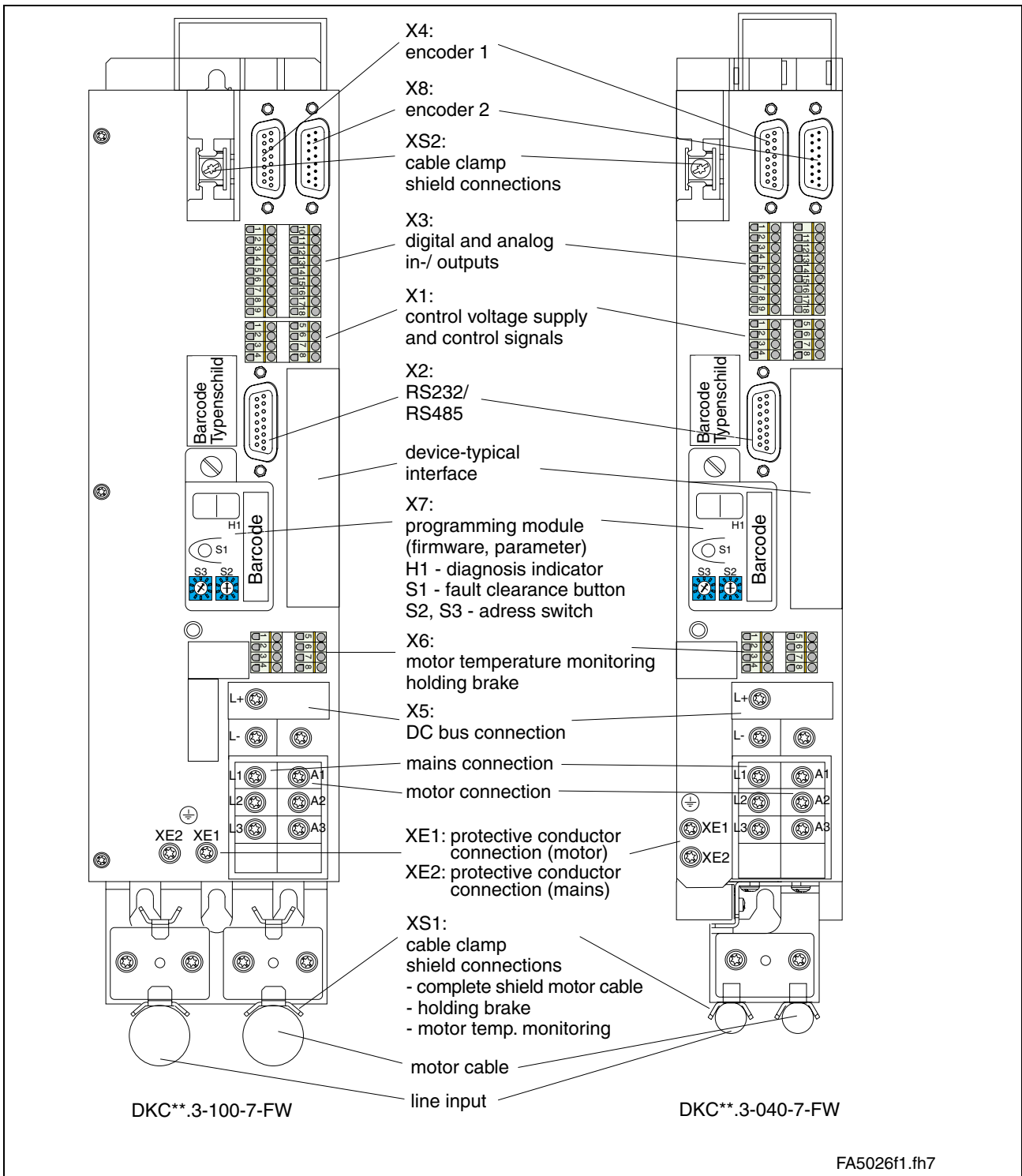

Fig. 4-43: Front view DKC**.3-040-7-FW and DKC**.3-100-7-FW with Connectors

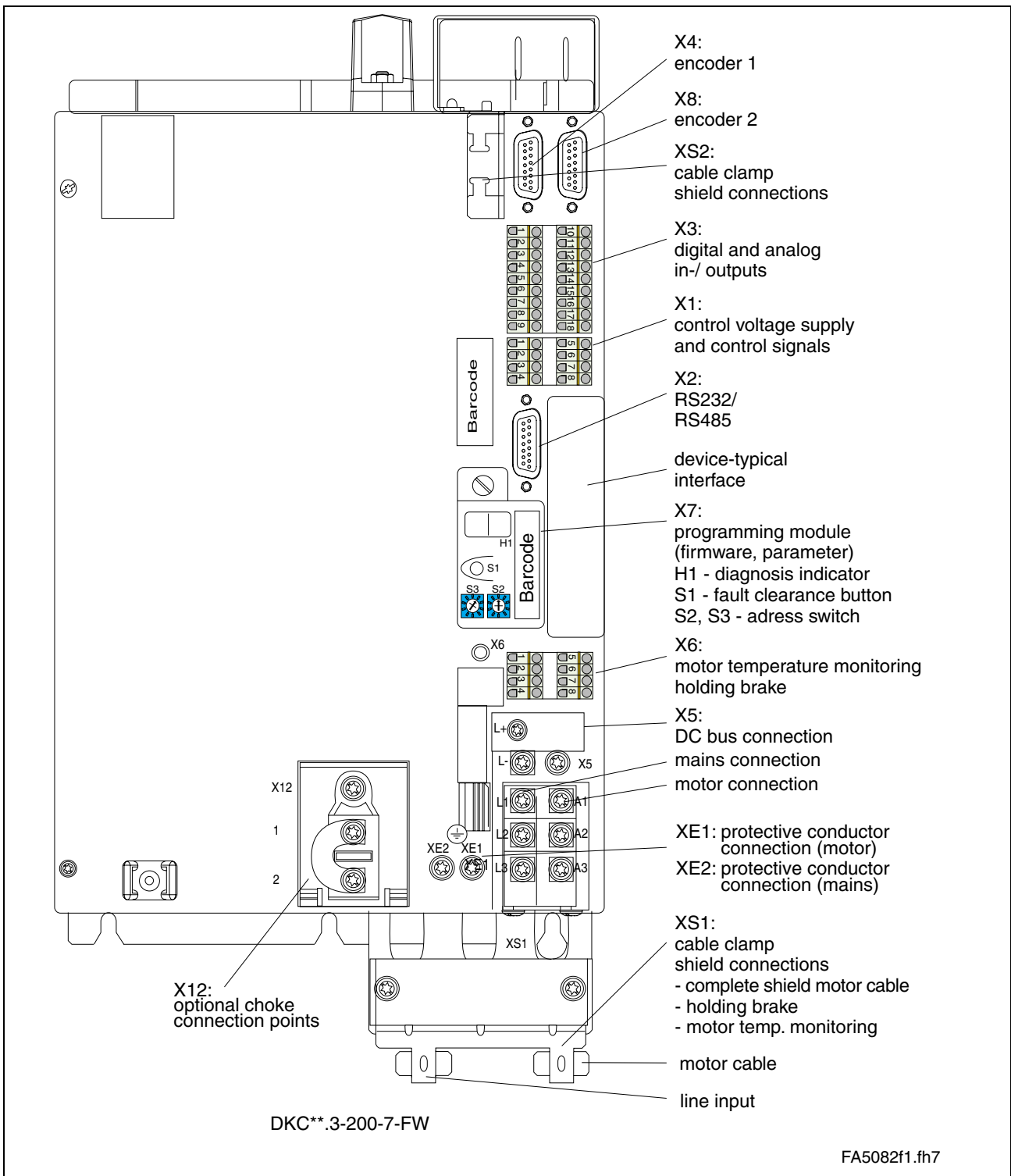

Fig. 4-44: Front view DKC**.3-200-7-FW with connectors

Connections on top of the drive controller

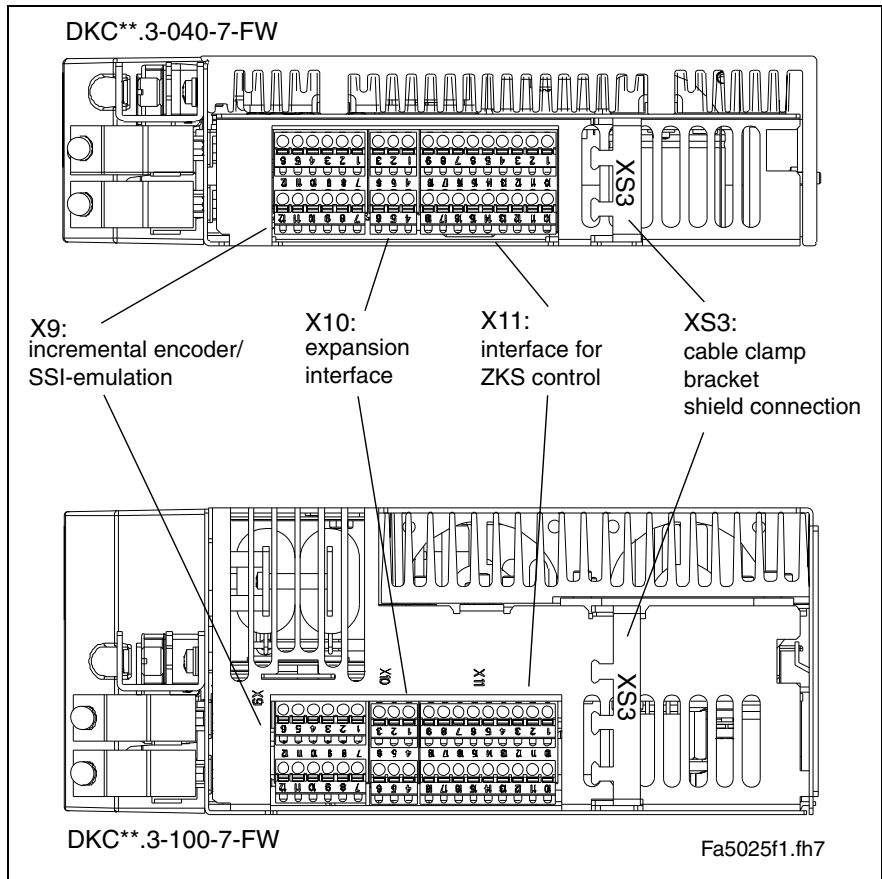

Fig. 4-45: Connections on top of unit for DKC**.3-040-7-FW and DKC**.3-100-7-FW

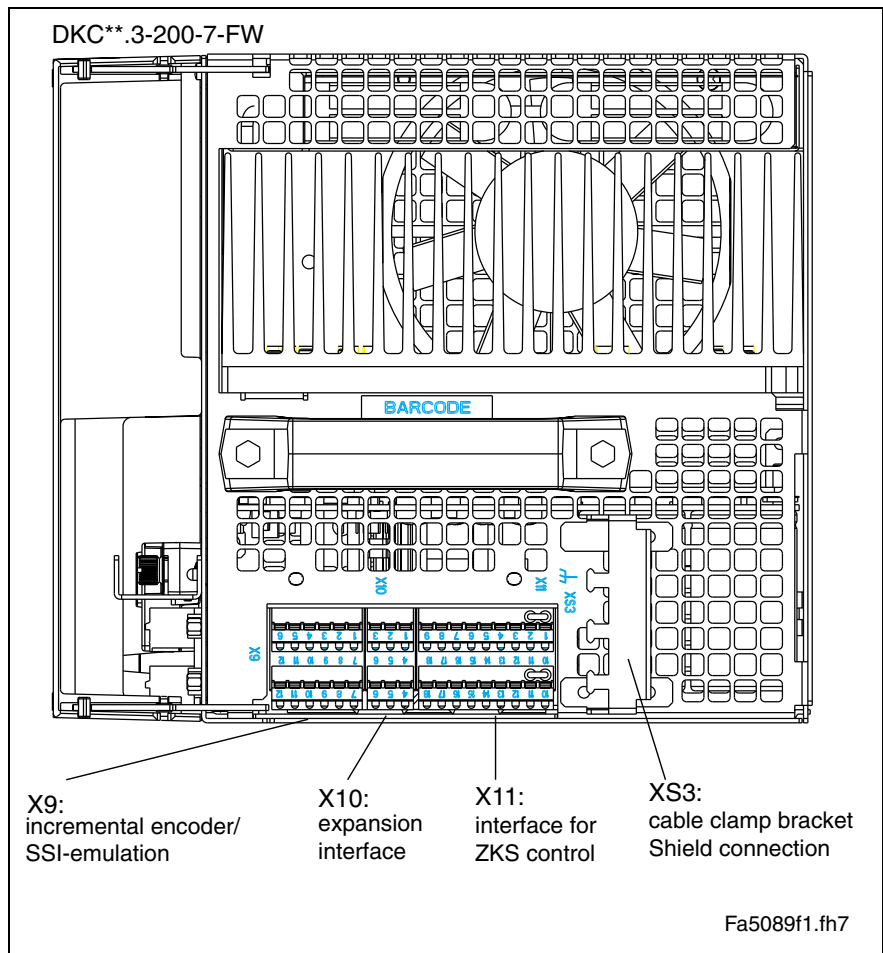

Fig. 4-46: Connections on top of unit for DKC**.3-200-7-FW

Independent of the drive controller type – total connecting diagram

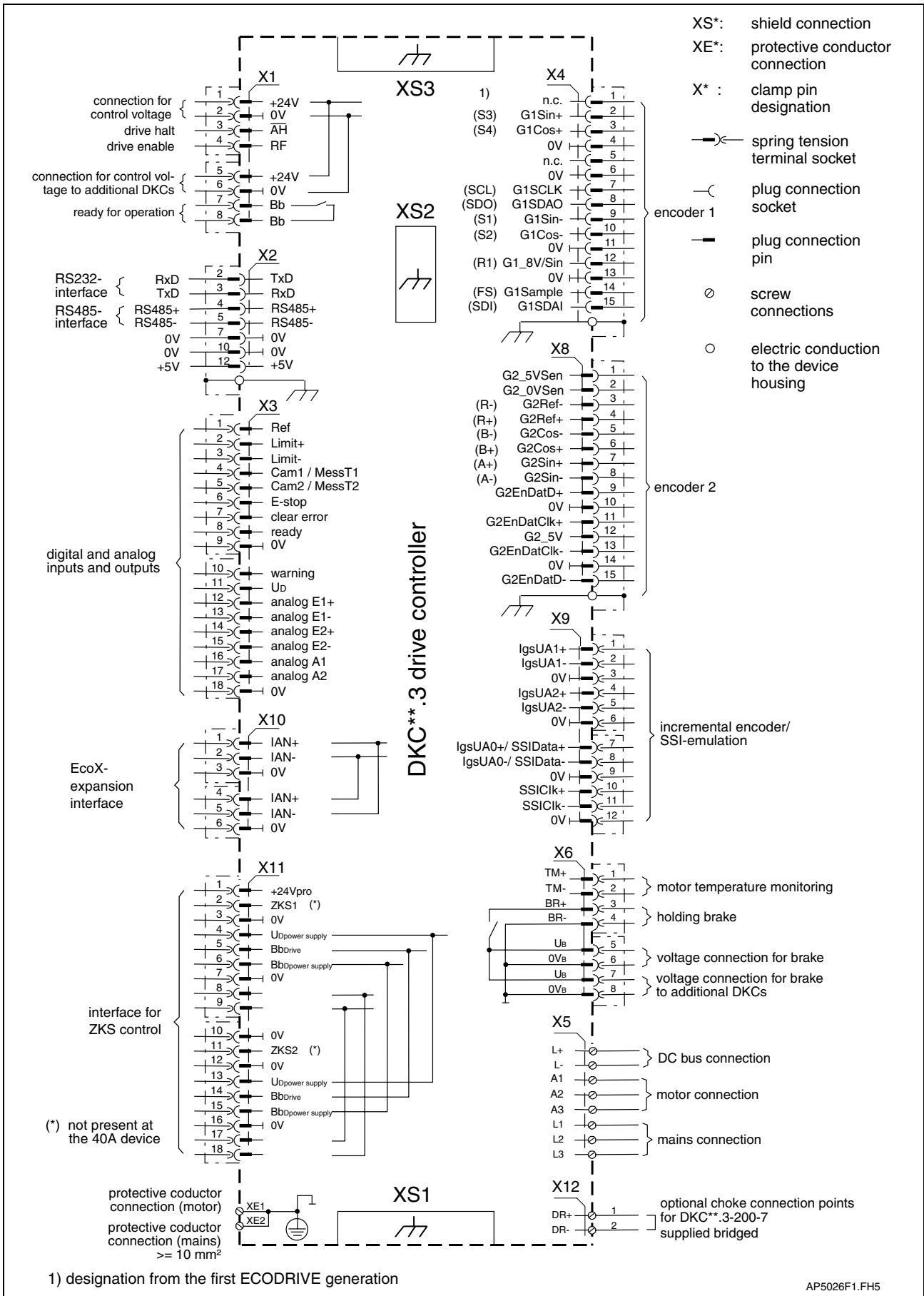

Fig. 4-47: Total connection diagram for DKC**.3

X1, Connections for Control voltage

Technical description of connector

Illustration:

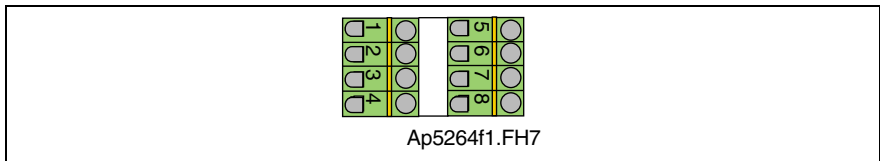

Fig. 4-48: Connector X1

Design:

Type	No. of pins	Design
Spring contact	2 x 4	Bushing on connector

Fig. 4-49: Design

Connection cross section:

Cross section single wire [mm ²]	Cross section multi core wire [mm ²]	Cross section in AWG Gauge no.:
0,2-2,5	1,5-2,5	16-12

Fig. 4-50: Connection cross section

24V control voltage supply (+24V and 0V)

Connection +24V and 0V:

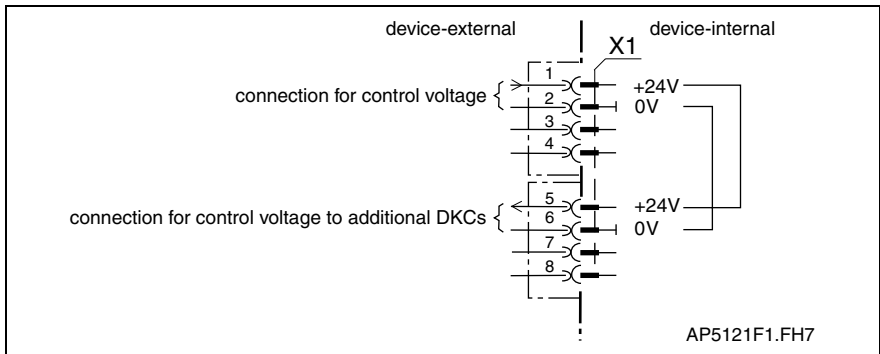

Fig. 4-51: Connections for control voltage

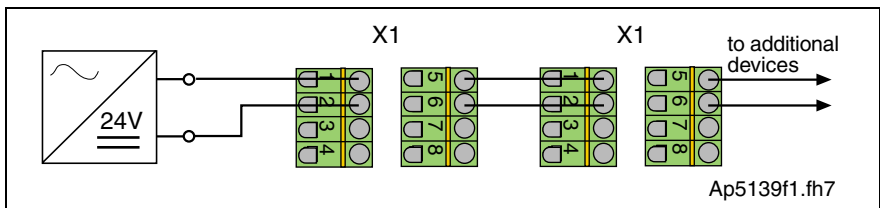

Fig. 4-52: Looping through control voltage

Example for application: see page 16-6.

Connection loads +24V and 0V:

Voltage at X1/1 against X1/2:	See page 4-13 "Control voltage connection for DKC"
Current or power consumption X1/1:	
Reverse voltage protection:	Via allowed voltage range using internal protection diodes
Max. allowed current load when looping through the control voltage via X1.1/2 to X1.5/6:	DC 10 A

Technical data for control voltage supply: see page 4-13 Control voltage connection for DKC.

Note: Strong mechanical influence on the test tap of the terminals can increase the transition resistance and destroy the terminals.

Note: The input 0 V is connected directly to the device potential. The utilization of an insulation monitoring for +24 V and 0 V against device is therefore not possible!

**wire
+24V and 0V:**

wire cross section:	min. 1 mm ² for looping through: min. 2,5 mm ²
wire routing:	parallel if possible
Max. allowed inductance between 24V source and X1:	100 µH (equals about 2 x 75 m)

Note: If the cross sections of the lines for looping through the control voltage are too small, the terminals can be damaged.

Note:

- Exceeding allowed control voltage generates error message "+24 volt error". (=> See also firmware functional description.)
 - Control voltage failure causes the running motor to coast torque-free (without brake).
See page 11-5: "Control Circuits with internal DC bus dynamic brake (ZKS)"
-



DANGER

Dangerous movements due to unbraked coasting of motor with control voltage failure!

- ⇒ Personnel should not remain within the area of the machine with moving parts. Possible preventive steps against unauthorized access are:
- protective fencing
 - bars
 - covers
 - light barriers
- ⇒ The fences must be able to withstand the maximum possible force that the machine can generate.
-

Drive halt (AH) and Drive enable (RF)

Note:

- Inputs work with inactive bus communication.
- Inputs don't work with active bus communication (SERCOS interface, Profibus-DP, ...).

**Connection
AH and RF:**

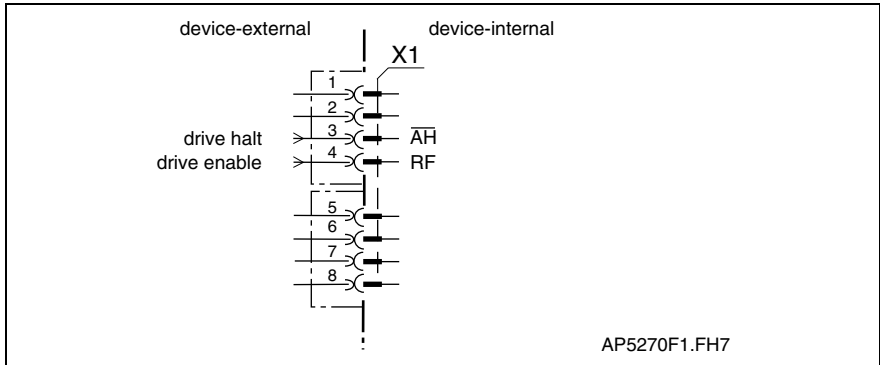
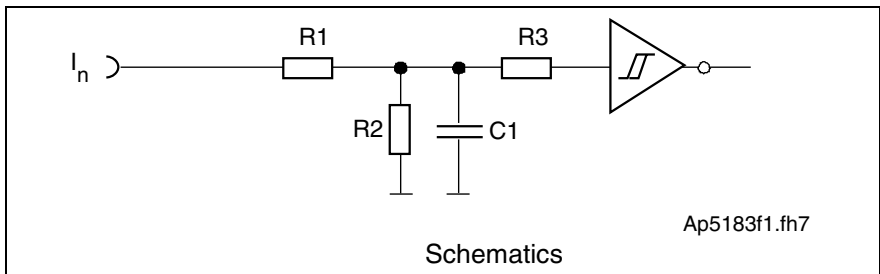

Fig. 4-53: Connections for drive halt and drive enable

**Input circuit
AH and RF:**



- R1: 10k
 R2: 3k3
 R3: 10k
 C1: no data

Fig. 4-54: Input circuit

**Inputs
AH and RF:**

Input voltage:	min.	max.
High	16 V	30 V
Low	-0.5 V	3 V
Input resistance	13.3 kOhm ± 5%	
Reaction time	See firmware functional description	

Fig. 4-55: Inputs

AH: The drive halt function is used to bring an axis to standstill with defined acceleration and jerk (see firmware functional description).

RF: The input drive enable (RF) activates the drive with a 0-1 edge.

Note: If the inputs are controlled by a power supply other than the DC24 volt supply of the drive controller, then the reference lead of the other power supply must be connected to X1.2 (0 V).

Ready to operate contact Bb

Connection
Bb:

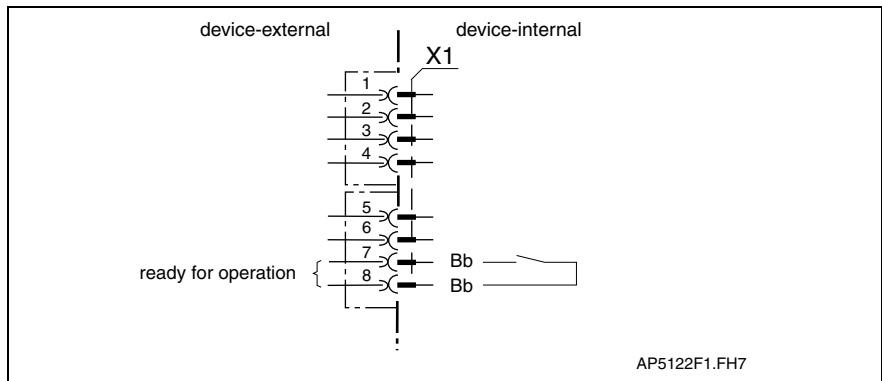

Fig. 4-56: Connections for ready to operate contact

Loadability of the connection
Bb:

max. Switching voltage:	DC 40 V
max. Switching current:	DC 1 A
max. continuous current:	DC 1 A
Minimum contact load:	10 mA
Guaranteed number of switching operations at max. time constant of load < 50 ms:	250,000

Switching states
Bb:

The Bb contacts opens:

- if control voltage for DKC is not applied
- if 24 volts not present at the emergency stop input when the E-stop function is activated (depends on parameterization, see function description).
- With an error in the drive (depends on parameterization, see firmware functional description: "Power off on error").

How to use the contact, see page 11-2 "Control Circuits for the Mains Connection"



WARNING

Damage possible if Bb contact not connected!

The ready to operate contact Bb acknowledges the drive is ready for mains voltage.

- ⇒ Integrate Bb contact as per "Control Circuits for the Mains Connection".
- ⇒ The evaluation of the Bb contact by a PLC may not cause any operating delay of more than 10 ms.

X2, Serial Interface

Note: Serial interfaces are generally used for programming, parameterization and diagnoses upon commissioning and during service. It can be operated either as RS232 or RS485.

Technical description of connector

Illustration:

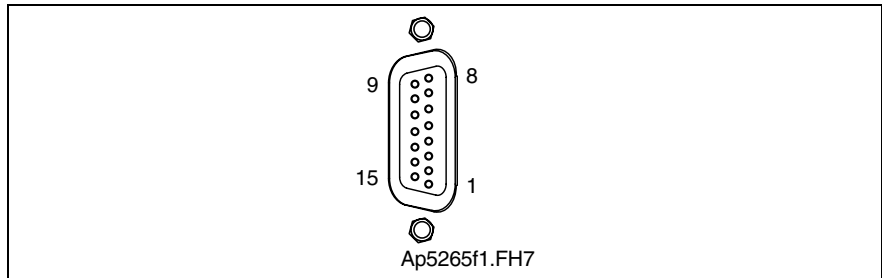

Fig. 4-57: Connector X2

Design:

Type	No. of pins	Design
D-SUB	15	Bushings on unit

Fig. 4-58: Design

Connection cross section:

Cross section single wire [mm ²]	Cross section multi core wire [mm ²]	Cross section in AWG gauge no.:
--	0.25-0.5	--

Fig. 4-59: Connection cross section

Short circuit protection

RS232	pin 2, 3 against each other against 0 V	present present
RS485	pin 4, 5 against each other against 0 V	present present

Fig. 4-60: Short circuit protection

RS232 interface

The RS232 interface is used for programming, parameterization and diagnoses at start up and service.

It makes possible:

- a participant number of maximum 1
- a transmission length of up to 15 m
- transmission rates of 9600/19200 baud

Using an RS232 interface only one drive at a time can be parametrized with the DriveTop start up program.

**Connection
RS232:**

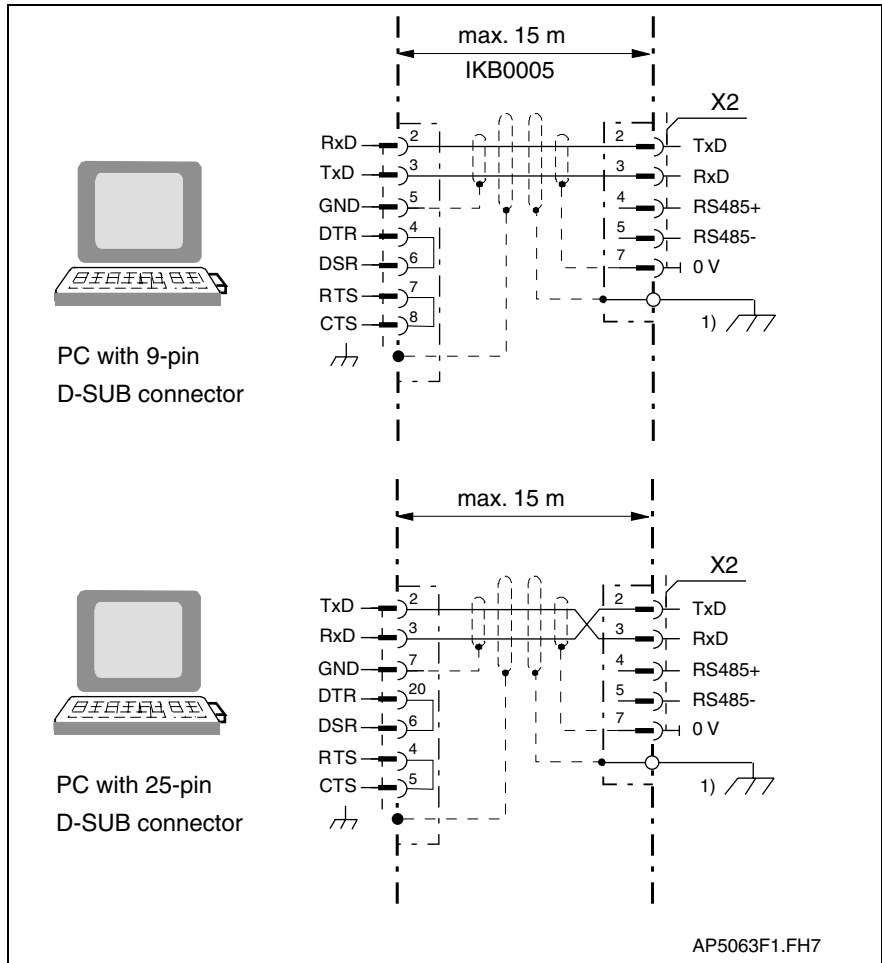

1) Connect the metallic connector case with the device potential using the fastening screws of the connector

Fig. 4-61: Connecting a PC to the RS232 interface on a DKC

See page 13-4: "Additional Accessories".

RS485 interface

The RS485 interface is used for programming, parameterization and diagnoses at start up and service.

It makes possible:

- the implementation of a serial bus with up to 31 participants connected via a two-wire cable (half duplex mode)
- A transmission length of up to 500 m
- Transmission rates of 9600/19200 baud
- The use of a centrally PC supported visualization unit

Using an RS485 enables the commissioning of several DKCs with DriveTop without changing the interface cables is possible.

The following options for working with RS485 are available

- RS232/RS485 converter between PC and drives
- RS485 plug-in card in PC

Please contact your PC supplier to help find solutions.

Installation notes for RS485 – cables

Note: Details are listed in "Electromagnetic compatibility (EMC) and control systems", doc. Type DOK-GENERL-EMV*****-PRxx.

Connection for RS485 interface:

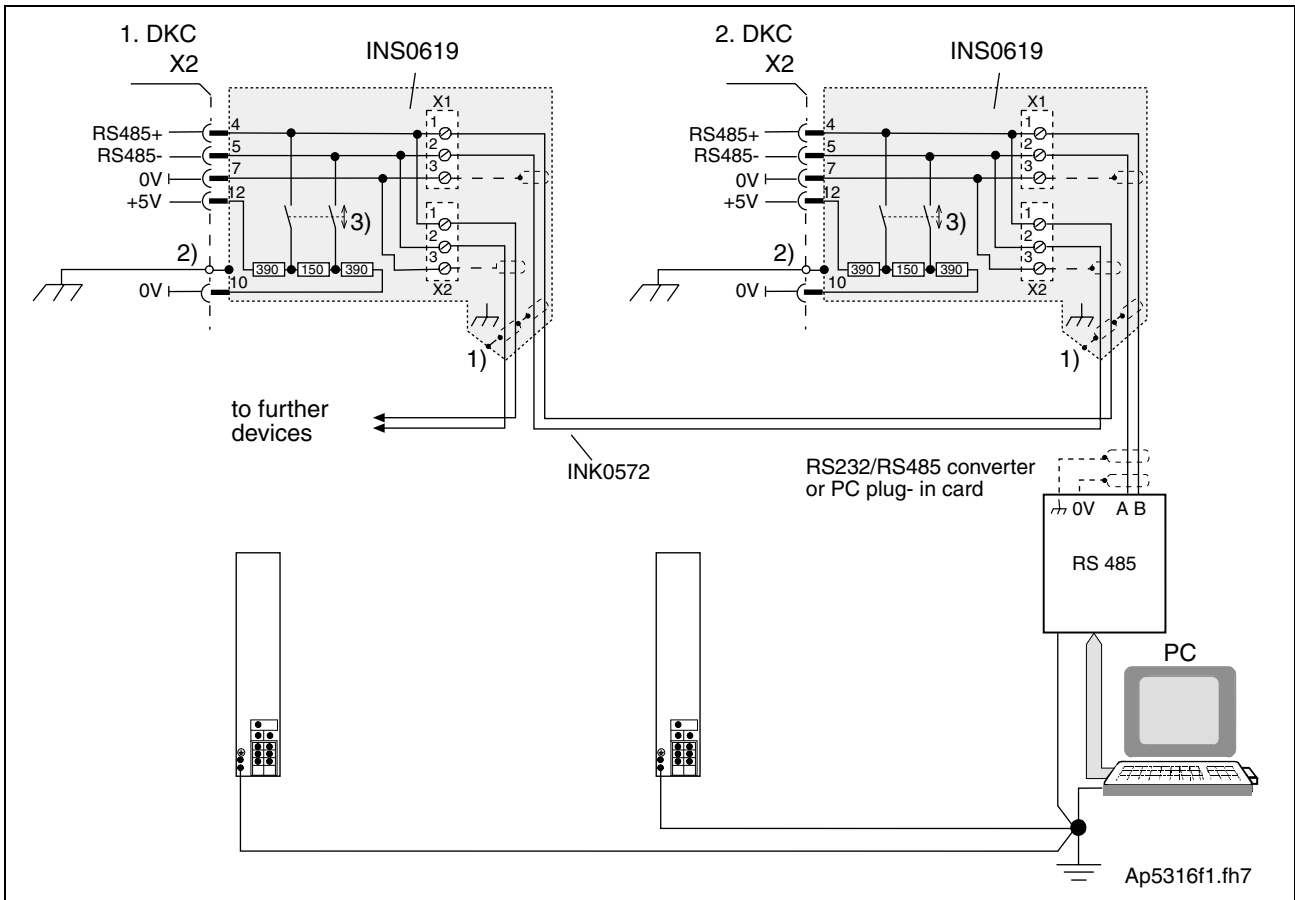

- 1): Connect outer screen to device potential on PC side and converter side (strain relief of metallic connector case)
- 2): Connect the metallic connector case with the device potential using the fastening screws of the connector
- 3): If the drive controller is fitted as the last participant of a RS485 bus, activate the bus termination. => Shift switch to "I".

Fig. 4-62: Connection example of RS485 interface

⇒ See also the firmware functional description: "Serial Communications"

X3, Digital and analog I/Os

Technical description of connector

Illustration:

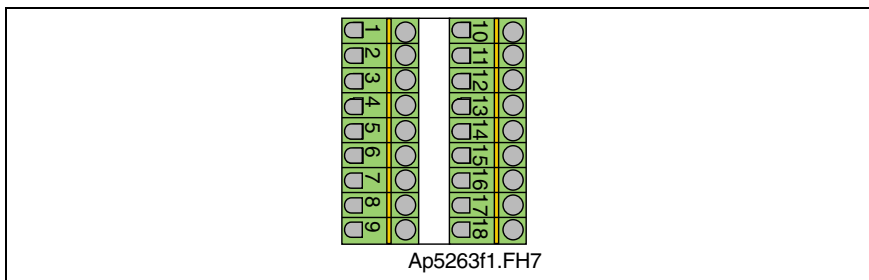

Fig. 4-63: Connector X3

Design:

Type	No. of pins	Design
Spring contact	2 x 9	Bushing on connector

Fig. 4-64: Design

Connection cross section:

Cross section single wire [mm ²]	Cross section multi core wire [mm ²]	Cross section in AWG Gauge no.:
0,2-2,5	0.2-1.5	24-16

Fig. 4-65: Connection cross section

Digital Inputs (Ref, Limit+, Limit-, Cam1/ MessT1, Cam2/ MessT2, E-Stop and clear error)

Connection Digital inputs:

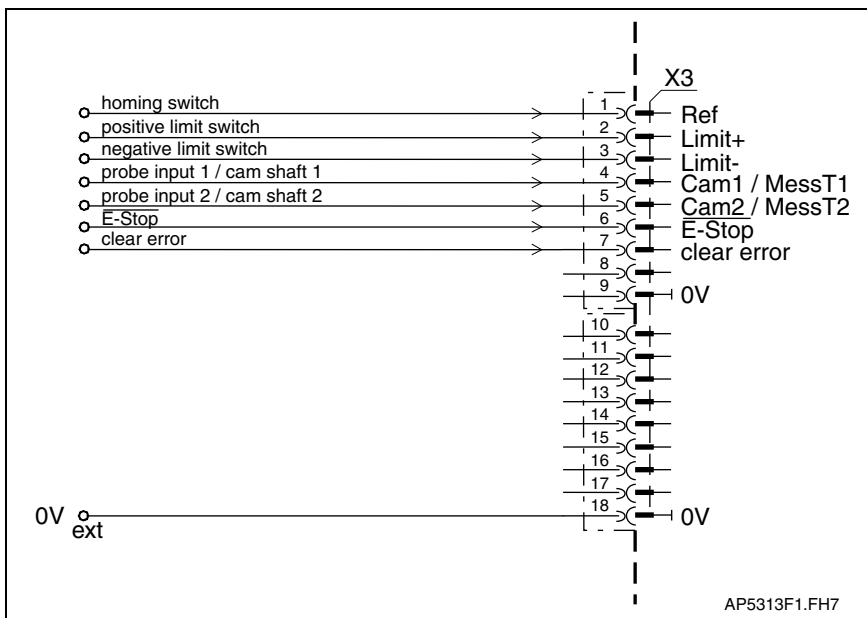
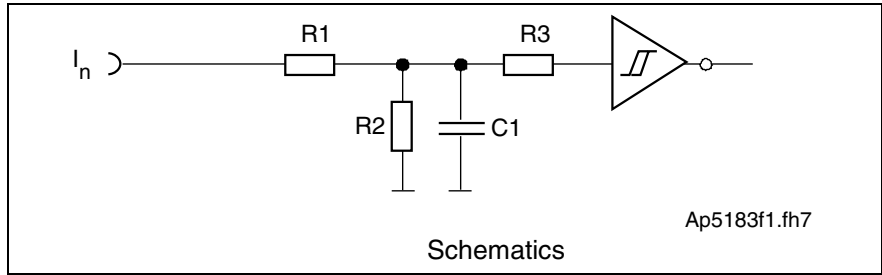

Fig. 4-66: Digital inputs

Input circuit
Digital inputs:



- R1: 10k
- R2: 3k3
- R3: 10k
- C1: no data

Fig. 4-67: Input circuit

Inputs
Digital inputs:

Input voltage:	min.	max.
High	16 V	30 V
Low	-0,5 V	3 V
Input resistance	13,3 kOhm ± 5%	
Reaction time	see firmware functional description	

Fig. 4-68: Inputs

Note: If the inputs are controlled by a power supply other than the DC24 volt supply of the DKC, then the reference lead of the other power supply must be connected to X3.18 (0 V).

- Homing switch:** The positive edge of the homing switch is always evaluated.
- Limit+, Limit-:** End switches can be N/C or N/O depending on how the drive is parametrized. See firmware functional description.
- Probes:** Position and time measurements are read using two binary input signals.
- Cams:** Switching-signal dependent continuous block switching makes transition to the next block possible with the use of an external switching signal.
- Note:** If the functions probe and following block mode are simultaneously activated, then both functions evaluate the inputs independently of each other.
- E-Stop:** At delivery, the E-stop function is deactivated depending on what has been parametrized. See firmware functional description.
- Clear error:** With a positive edge at the input "clear error", all errors (up to four) are cleared. With the actuation of the S1 button (firmware module) only the error in the display is cleared and any other errors present are then shown.
- Note:** The errors entered in the back-up memory are not cleared with the "clear error" input.

Digital outputs (ready, warning and U_D-message)

Connection
Digital outputs:

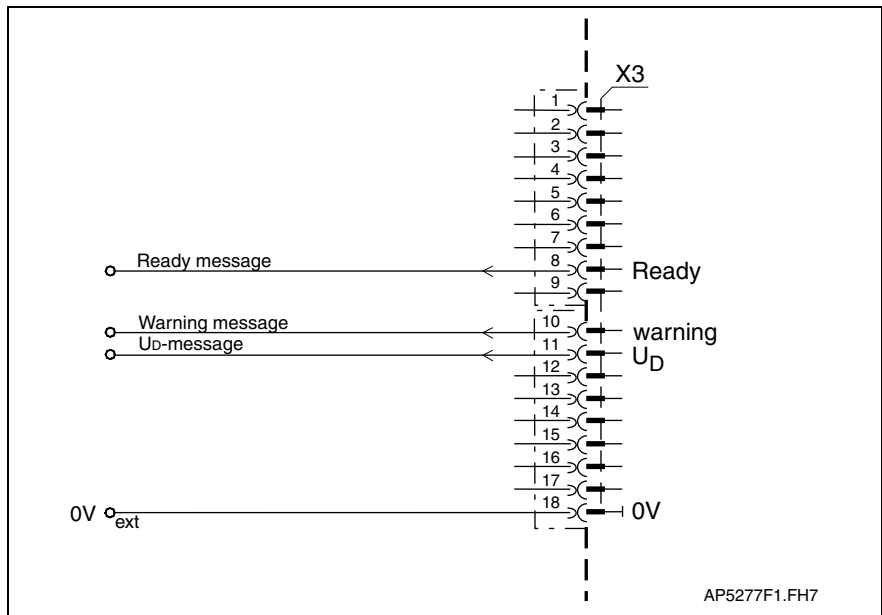
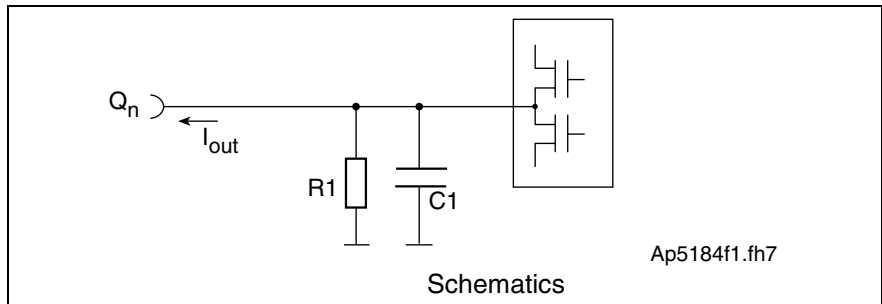

Fig. 4-69: Control outputs

Output circuit connection
Digital outputs:



R1: 20k
C1: no data

Fig. 4-70: Output circuit

Output connections
Digital outputs:

Output voltage:	min.	max.
High	16 V	U _{ext} (at X1.1-1V)
Low	-0.5 V	1.5 V
Output current I _{out}	80 mA	
Rise and drop time	about < 600 ns	
Overload protection	- short circuit protection; at I _{out} > 300 mA the outputs switch off - thermal shutdown	

Fig. 4-71: Outputs

Warnings: Depending on operating mode and parameter programming a number of monitoring functions are conducted. If a condition is detected that still allows for correct operations but would eventually lead to an error, then the warning is set to high.

⇒ See also firmware functional description.

Ready: If the unit is ready for the drive enable, then the output ready is set to high.

The output is set to low

- with a pending error
- with DC bus voltage < (0.75 x threshold value of applied mains voltage)
- with lacking control voltage

⇒ See also functional firmware description: "Ready".

U_D-message: Once the minimum voltage in the power DC bus is reached, then the controller is ready to output power and the U_D output is set to high. Signal U_D-message has a special meaning for "central supply" whereby it supplies input U_D power supply.

See page 4-88: "UD power supply".

Delay time t_d from applying mains voltage to the setting of the U_D signal is

- **single phase** mains connection:

$$t_d = 2 * R_{softstart} * 1.2 * C_{ZW} * 3 + 50ms$$

t_d delay time
R_{softstart} take value from "technical data" list
C_{ZW}: sum of DC bus capacitors

Fig. 4-72: Delay time for single phase mode

See page 4-36: "Allowed DC bus continuous power with single-phase mains connection".

- **three-phase** main connection:

$$t_d = R_{softstart} * 1.2 * C_{ZW} * 3 + 50ms$$

Fig. 4-73: Delay time for three-phase mode

Resulting load resistance R: This resistance of all mains voltages connected to DKC at one DC bus

$$\frac{1}{R} = \frac{1}{R_{softstart1}} + \frac{1}{R_{softstart2}} + \dots + \frac{1}{R_{softstartn}}$$

Fig. 4-74: Load resistance

Resulting DC bus capacitance C: The resulting DC bus capacitance of all units on one DC bus

$$C = C_{ZW, DKC1} + C_{ZW, DKC2} + \dots + C_{ZW, DKCn} + C_{ZW, CZM}$$

Fig. 4-75: DC bus capacitance

Analog inputs 1 and 2

Connection
Analog inputs:

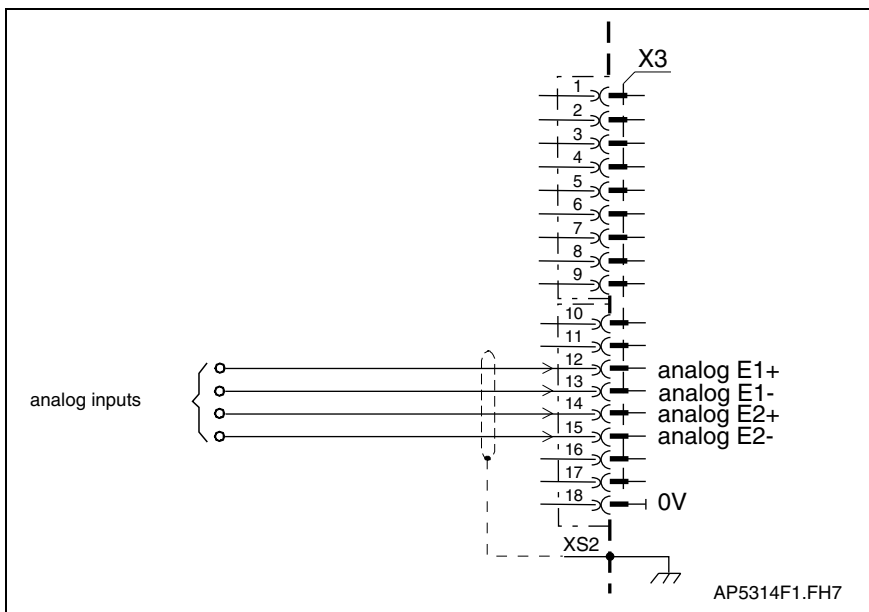
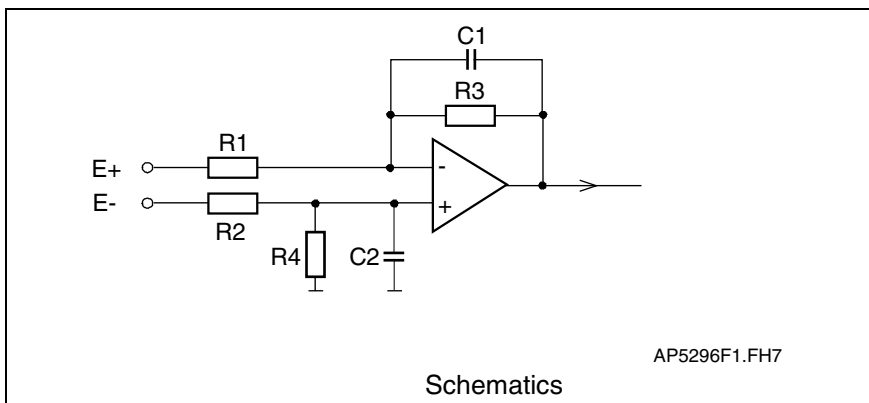

Fig. 4-76: Analog inputs

Input circuit
Analog inputs:



- R1: 20k
- R2: 20k
- R3: 20k
- R4: 20k
- C1: no data
- C2: no data

Fig. 4-77: Input circuit

Inputs
Analog inputs:

	Working range	max.
Input voltage range		
between E+ and E-:	± 10 V	± 15 V
between E+ and 0 V:	± 10 V	± 15 V
between E- and 0 V:	± 10 V	± 15 V
Input current	no data	
Input resistance for differential signal	40 kOhm ± 5%	
AD converter	12 Bit	
Resolution per bit	4,88 mV	
Limit frequency	800 Hz	
Probe	See function description	

Fig. 4-78: Inputs

Analog inputs: The analog differential inputs 1 and 2 can be parametrized as needed and can be used, for example, as an analog speed command value inputs, override inputs or for analog torque reduction.

⇒ See Function Description also: "Analog inputs".

Analog outputs 1 and 2

**Connection
Analog outputs:**

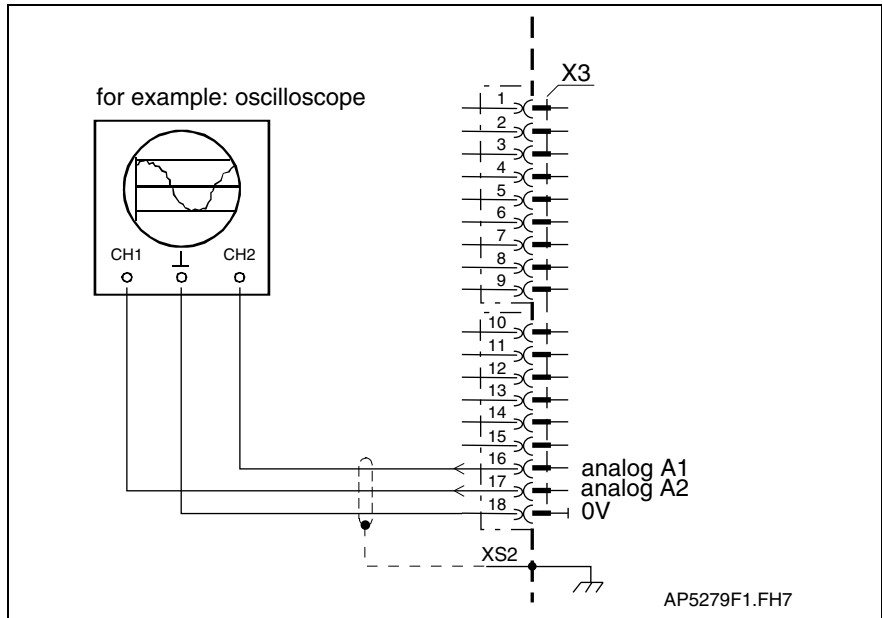

Fig. 4-79: Connection example of outputs A1 and A2



CAUTION

Risk of damage!

⇒ Allowed maximum cable length at X3.16 and X3.17: **3 m.**

**Outputs
Analog outputs:**

Output voltage	min.	max.
between A1 and 0 V:	- 10 V	+ 10 V
between A2 and 0 V:	- 10 V	+ 10 V
output current	max. 2 mA	
output resistance	150R	
DA converter	8 Bit	
Resolution per bit	78 mV	
short-circuit and overload protection	not present	
Probe	See firmware functional description	

Fig. 4-80: Outputs

Analog outputs: Analog outputs 1 and 2 can be freely parameterized and used for diagnostics or implementation of master/slave mode.

⇒ See also firmware functional description: "Analog outputs"

X4, Encoder 1

Technical description of connector

Illustration:

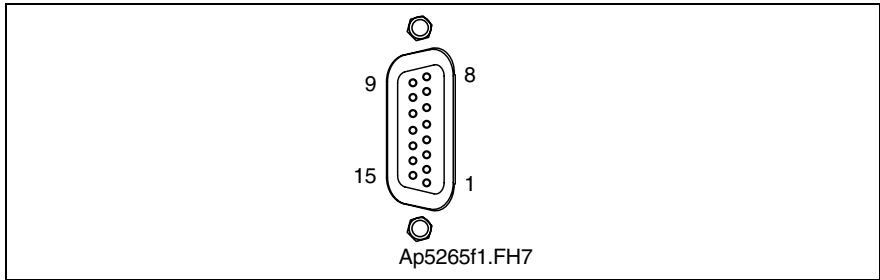

Fig. 4-81: Connector X4

Design:

Type	No. of pins	Design
D-SUB	15	bushing on unit

Fig. 4-82: Design

Connection cross section:

Cross section single wire [mm ²]	Cross section multi core wire [mm ²]	Cross section in AWG gauge no.:
--	0.25-0.5	--

Fig. 4-83: Connection cross section

Encoder 1

Connection Encoder 1:

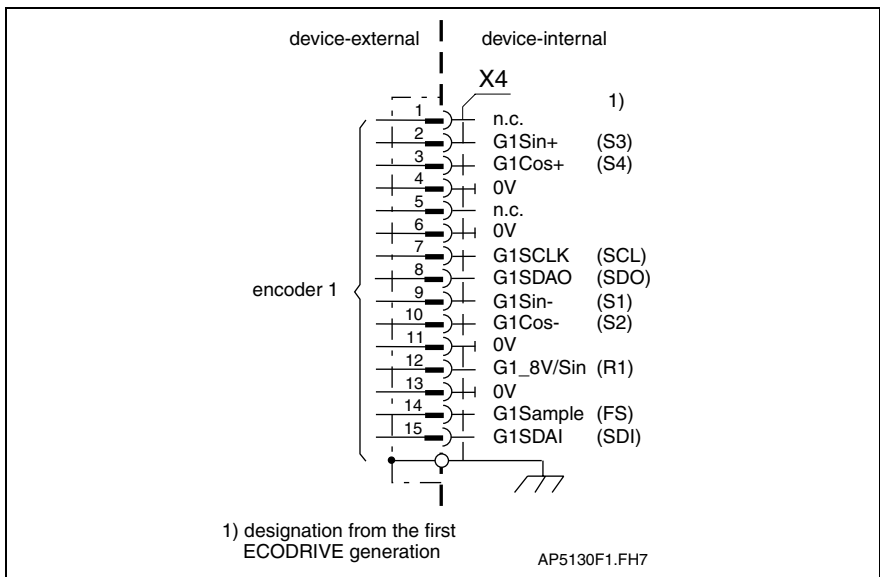

Fig. 4-84: Encoder 1

Shield connection: Via D-subminiature mounting screws and metal connector housing.

G1SCLK: Clock lead for I²C interface

G1SDA0, G1SDAI: Data lead for I²C interface

G1Sample: Control signal for encoder initialization

G1Sin+ (S3), G1Sin- (S1): Input circuit G1Sin+ (S3), G1Sin- (S1):

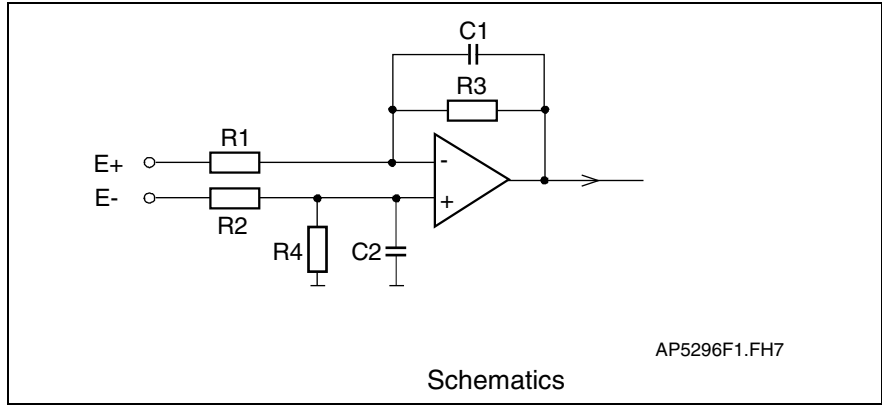

- R1: 10k
- R2: 10k
- R3: 20k
- R4: 20k
- C1: no data
- C2: no data

Fig. 4-85: Input circuit

Features of the differential input circuit G1Sin+ (S3), G1Sin- (S1):

	Digital servo feedback	Resolver
max. allowed amplitude encoder signal	(1,0 + 0,1) Vss	9,0 Vss
Evaluation AD converter	12 Bit	12 Bit
Limit frequency	75 kHz	--
Input resistance	20k ± 5%	

Fig. 4-86: Features of the differential input circuit

G1Cos+ (S4), G1Cos- (S2): See G1Sin+ (S3), G1Sin- (S1)

G1_8V/Sin: Features of the encoder output amplifier stage G1_8V/Sin:

	Digital servo feedback	Resolver
Output voltage	8 V _{DC} ± 0,2V	18,2 Vss (sine with 4 kHz)
max. output current	DC 250 mA	AC 70 mA eff.
min. DC resistance of the load	--	35 R

Fig. 4-87: Features of the encoder output amplifier stage

Signal allocation to the actual position value

Signal allocation (X4)	signal designation	signal form	actual position value (with default setting)
	G1Sin+(S3) G1Sin-(S1) G1Cos+(S4) G1Cos-(S2)	DSF (sine 1 Vss without 120 Ohm matching resistor, I ² C-Bus)	increasing
 amplitude-modulated signal	G1Sin+(S3) G1Sin-(S1) G1Cos+(S4) G1Cos-(S2)	Resolver	increasing

Fig. 4-88: Signal allocation to the actual position value

Note: default setting:
 => see firmware functional description: "Motor Encoder" (Encoder 1).

Connecting the Measuring System

See page 1-4: "An Overview of Measuring Systems Supported".

X5, DC bus, Motor and Mains Connections

Technical description of connector

Illustration:

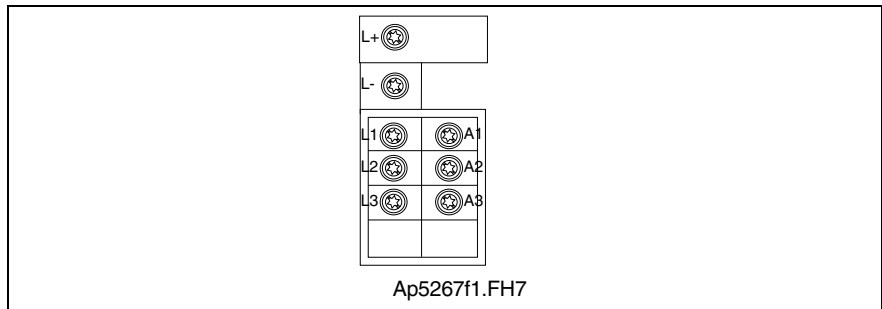

Fig. 4-89: Connector X5

Design:

Type	No. of pins	Design
connection block	2 / 3 / 3	screw-in connection for ring terminals M5

Fig. 4-90: Design

Tightening torque:

min. tightening torque [Nm]	max. tightening torque [Nm]
2.5	3.0

Fig. 4-91: Tightening torque

Connection cross section:

Cross section single wire [mm ²]	max. connectable cross section [mm ²]	max. Cross section in AWG gauge no.:
--	25	--

Fig. 4-92: Connection cross section

DC bus connection

The DC bus connection connects several controllers to each other plus it connects controllers together with auxiliary components

- Increase allowed DC bus continuous power
- Increase allowed bleeder continuous load
- Allow connections for "Central supply"

Connection DC bus:

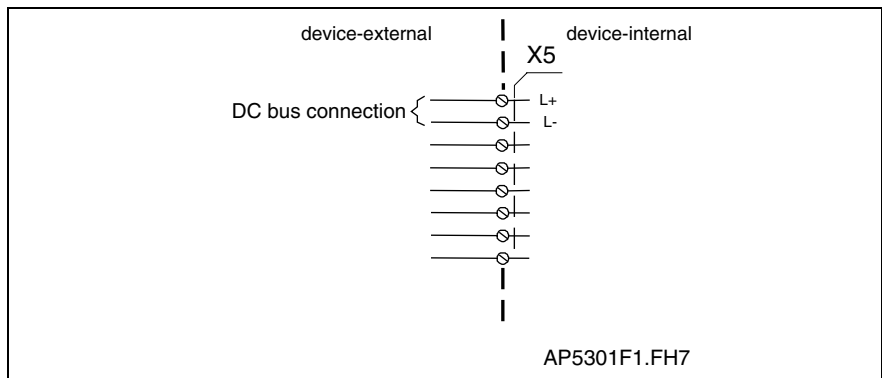

Fig. 4-93: DC bus connection



Damage possible if DC bus connections L+ and L- are reversed!

⇒ Make sure polarity is correct.

CAUTION

wire DC bus: If the DC bus rails supplied do not make a connection possible, then use short twisted wires to do so.

wire length:	max. 2 x 1 m
wire cross section:	min. 10 mm ² , not smaller than the cross section of the mains supply lead
wire protection	With a fuse in the mains connections
Voltage resistance of individual wires to ground	≥ 750 V (e.g., litz wires - H07)

Motor connection

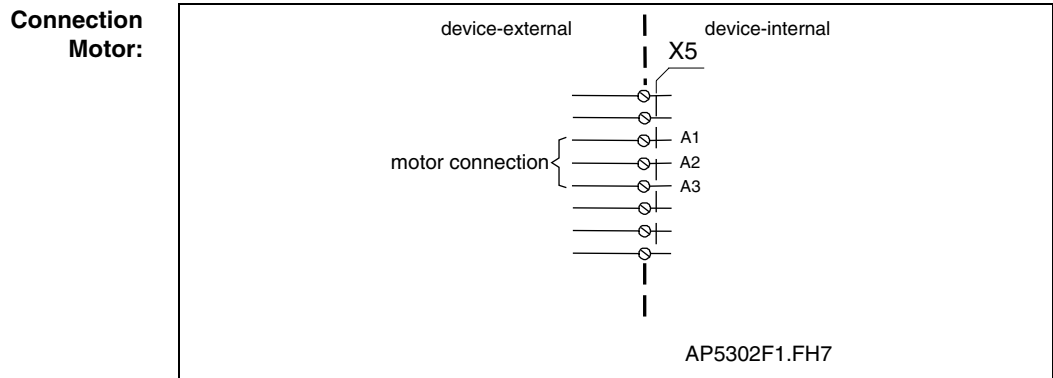

Fig. 4-94: Motor connections

Cable Motor: Use Rexroth Indramat motor power cables to connect motor and controller.

Note: For technical data on connections and cross sections, see the motor project planning manual.

Cable length:

Maximum length equals 75 m:

- With two connections between controller and motor (e.g., plugs at exit of control cabinet and at machine)
- Standard cables from Rexroth Indramat
- Ambient temperatures of ≤ 40 °C per EN 60 204
- Switch frequency of 4 kHz

Maximum allowed capacitance per unit length at A1, A2, A3:

- with regard to ground: 0.5 nF/m
- cable to cable: 0.5 nF/m

Maximum allowed inductance per unit length an A1, A2, A3:

- 100 nH/m

To maintain EMC values, the motor cable length is limited with a switching frequency of > 4 kHz. It is largely dependent on the application and ambient conditions at the installation and machine.

A guide value is listed below:

Cycle frequency drive controller	Max. length for class B, EN 55011	Max. length for class A, EN 55011
standard setting switching frequency 4 kHz	75 m	75 m
parameter setting switching frequency 8 kHz	25 m	50 m

Fig. 4-95: Guide value for maximum motor cable lengths



WARNING

No guarantee!

If third party cables are used, then the guarantee is forfeited for the entire system.

⇒ Use Rexroth Indramat cables!

Mains connections

The mains connector serves as the connection of the drive controller with the power supply.

Single-phase mains connection:

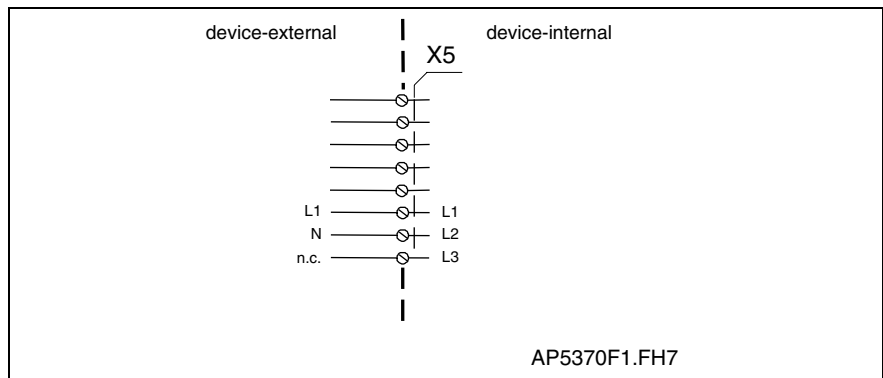

Fig. 4-96: Single-phase mains connection

Three-phase mains connection:

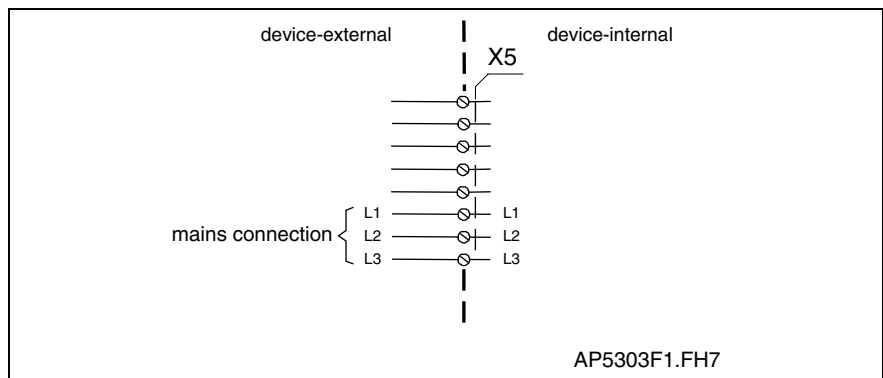

Fig. 4-97: Three-phase mains connection

Note: Mains connections should not be daisy-chained between the units (intermediate connectors for the supply source should be used).

See page 11-1: "Mains Connections"

X6, Motor temperature monitoring and holding brakes

Technical description of connector

Illustration:

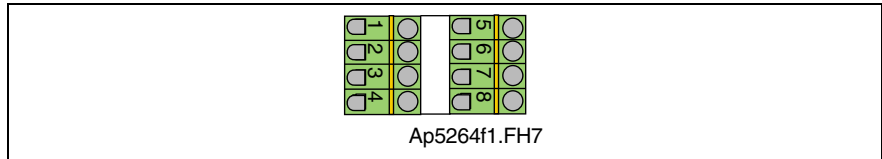

Fig. 4-98: Connector X6

Design:

Type	No. of pins	Design
Spring contact	2 x 4	Bushing on connector

Fig. 4-99: Design

Connection cross section:

Cross section single wire [mm ²]	Cross section multi core wire [mm ²]	Cross section in AWG Gauge no.:
0.2-2.5	1,5-2,5	16-12

Fig. 4-100: Connection cross section



CAUTION

Damages by exchanging the connectors X6.1-4 and X6.5-8!

⇒ Do not exchange connectors X6.1-4 and X6.5-8.

⇒ Only use lines with sufficient cross section.

Motor temperature monitoring (TM+, TM)

Connections TM+ and TM- are used to evaluate the temperature of connected Rexroth Indramat motors. These are equipped with a temperature-dependent resistor (either PTC or NTC dependent on the motor type) to monitor temperature. The connection leads are in the motor power cable.

Connection monitoring TM+, TM-:

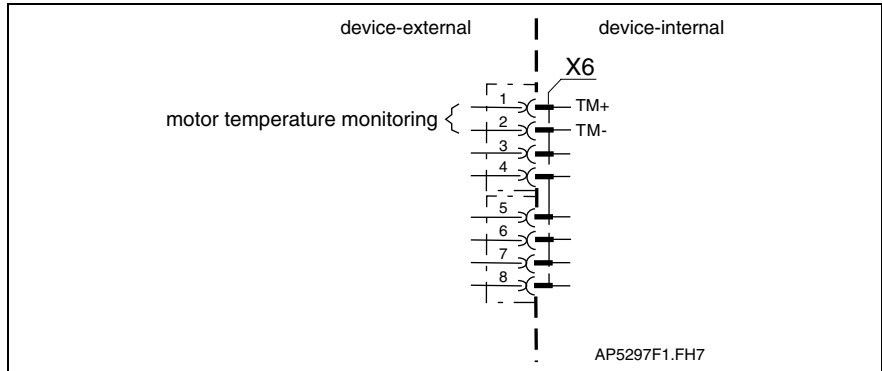
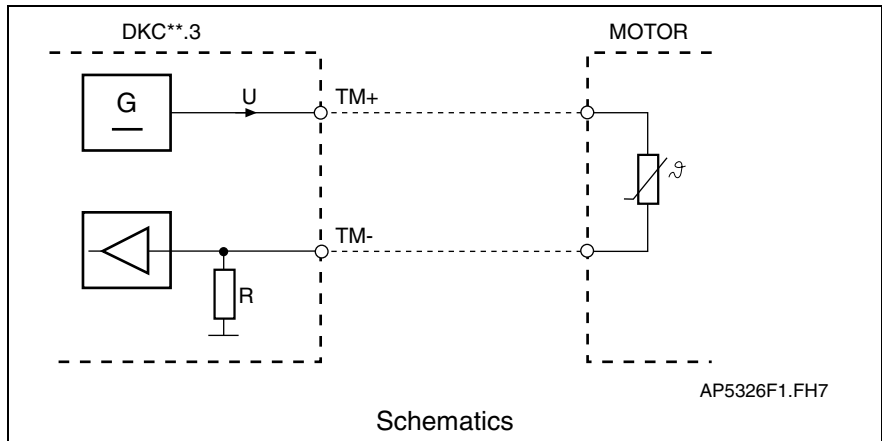

Fig. 4-101: Motor temperature monitoring

Motor temperature evaluation:



U: approximately 5 V
R: approximately 2 k

Fig. 4-102: Motor temperature evaluation

Note: Connections TM+ and TM- are only to be used with Rexroth Indramat motors.

⇒ See also firmware functional description : "Temperature monitoring".

Holding brake (BR+, BR-)



Dangerous movements! Danger to personnel from falling or dropping axes!

- ⇒ The standard equipment motor brake or an external brake controlled directly by the servo drive are not sufficient to guarantee the safety of personnel!
- ⇒ Personnel safety must be acquired with higher-ranking procedures:
 Dangerous areas should be blocked off with fences or grids.
 Secure vertical axes against falling or slipping after switching off the motor power by, for example:
 - Mechanically securing the vertical axes
 - Adding an external brake / clamping mechanism
 - Balancing and thus compensating for the vertical axes mass and the gravitational force

These connections control the holding brakes in the connected motors. For the switching performance, see function description. To connect external loads note allowed contact loads.

**Connection
BR+, BR-:**

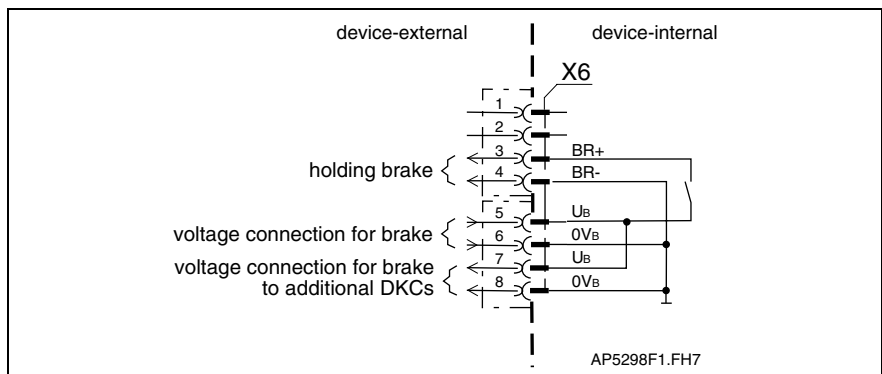

Fig. 4-103: Holding brake and voltage connection

Loadability of connections BR+, BR-:

Units	DKC**.3-040-7, DKC**.3-100-7	DKC**.3-200-7
max. switching voltage:	DC 40 V	
max. switching current:	DC 2 A	DC 4 A
max. continuous current:	DC 2 A	DC 4 A
Minimum contact load:	100 mA	
Guaranteed number of switches at max. time constant of load <50ms (L _{Bremse} /(24V/I _{Bremse})):	250.000	
Short-circuit and overload protection in the row to the contact	present	

Voltage connection for brakes

Note: The motor holding brake is not supplied by the controller. Given one voltage source for brake and control voltage, use parallel leads from the voltage source. Note the voltage range for the motor holding brake according to the motor projection.



CAUTION

Risk of damage!

⇒ The maximum allowed current load of the terminals for the voltage supply of the brake and the control voltage supply must also be observed in the case of a short circuit.

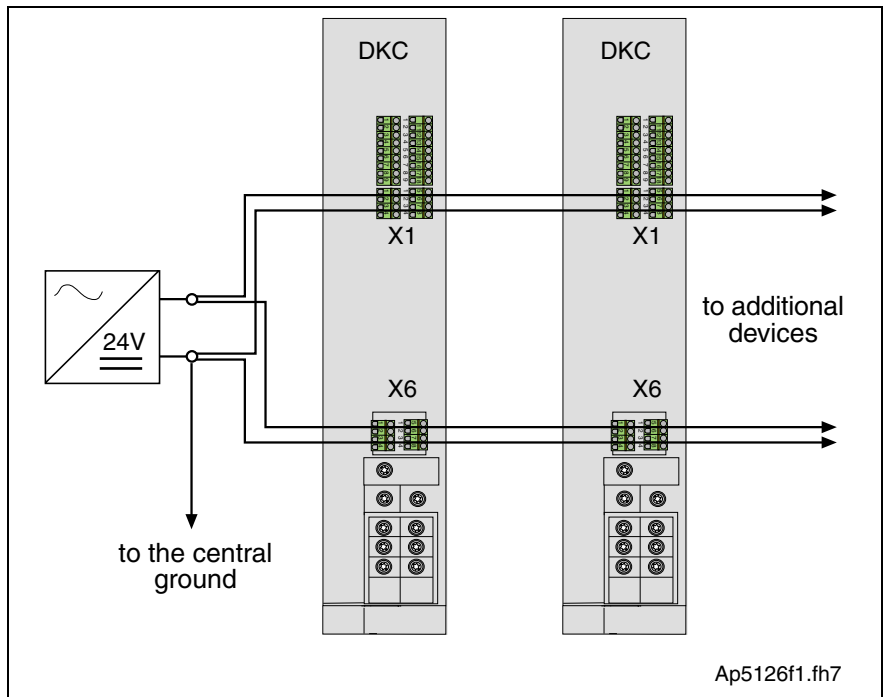

Fig. 4-104: Shared voltage source for brakes and control voltage supply

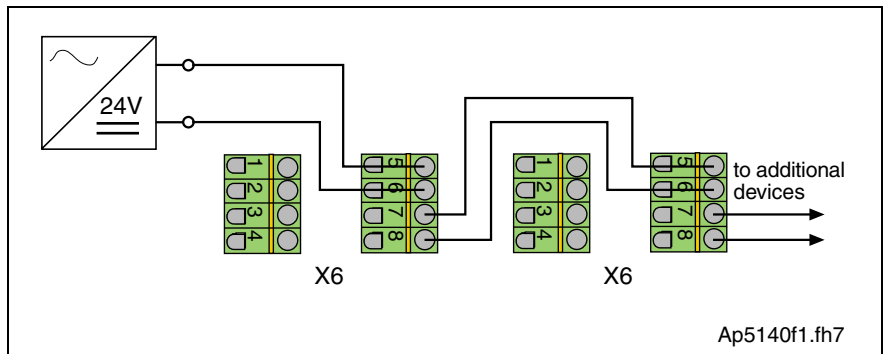

Fig. 4-105: Looping through the brake supply

Voltage connection for brakes on DKC:

max. voltage at X6.5/7 against X6.6/8:	DC 40 V
current consumption at X6.5 and needed supply voltage:	see "Technical data" brake in the motor manual
max. allowed current load when looping through brake supply over X6.5/6 to X6.7/8:	DC 10 A

Wire voltage connection for brake:

wire cross section:	min. 1 mm ² for looping through: min. 2.5 mm ²
Voltage resistance of single wire to ground	≥ 750 V (e.g.: litz wires - H07)
wire routing	parallel if possible (twisted)
max. inductance between 24 V source and X6	100 μH (equals about 2 x 75 m)



CAUTION

Risk of damage!

⇒ Risk of damage by increased transition resistance in the case of strong mechanical influence at the test tap.

Motor holding brake

Controlling the motor holding brake:

The controller controls the holding brake.

Technical data Motor holding brake:

Supply voltage, current consumption, linking, separating time, holding torque, etc. see motor manual.

Basic connection of motor power, holding brake and motor temperature monitoring

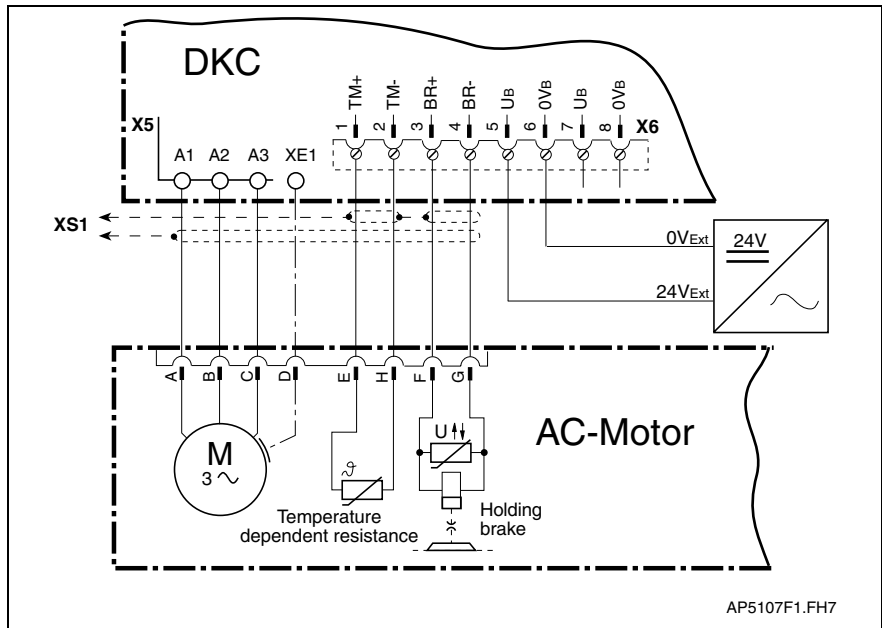

Fig. 4-106: Connection of motor cable, holding brake and temperature monitor for motors with connectors

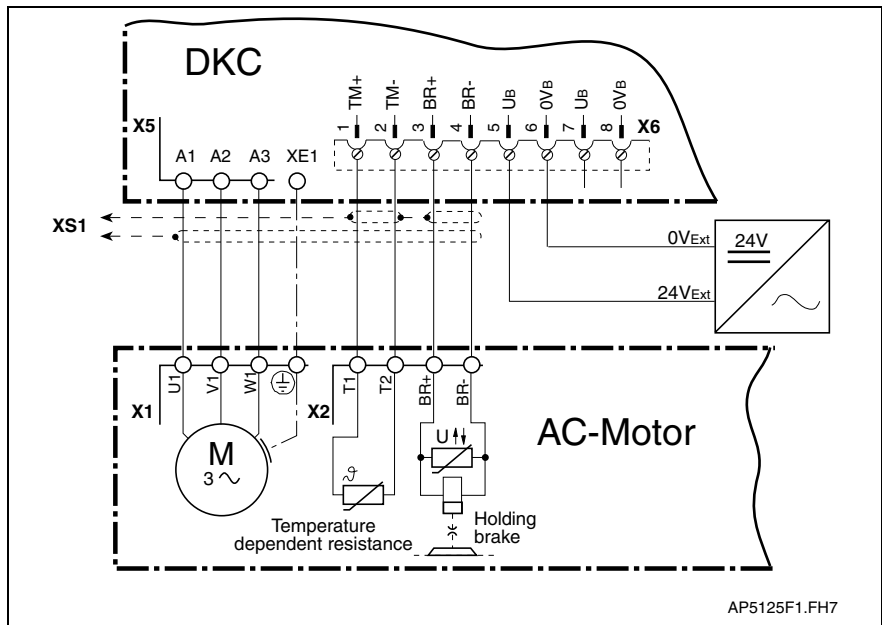

Fig. 4-107: Connection of motor cable, holding brake and temperature monitor for motors with connector box

Note: The cable designations and all details on making cables are outlined in the cable or motor document.

X7, Connection for Programming module

Programming module

The programming module can be broken down into

- Parameter module for user-specific parameters
- Firmware modules for unit-specific firmware

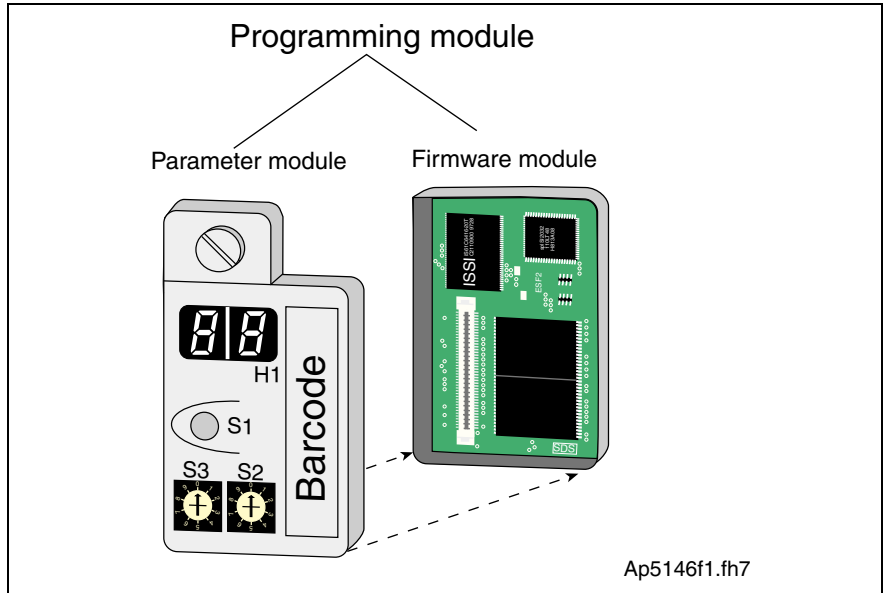

Fig. 4-108: X7, Programming module

- H1: Diagnostic display
- S1: Reset key
- S2, S3: Address switch

Setting the Drive Address

Switch S2, S3; drive address: Two decade switches are used to set the drive address. It can be set to any number between 1 and 99.

Example:

Switch setting S3 = 9 (value of tens)

Switch setting S2 = 1 (value of ones)

Drive address = $9 * 10 + 1 = 91$

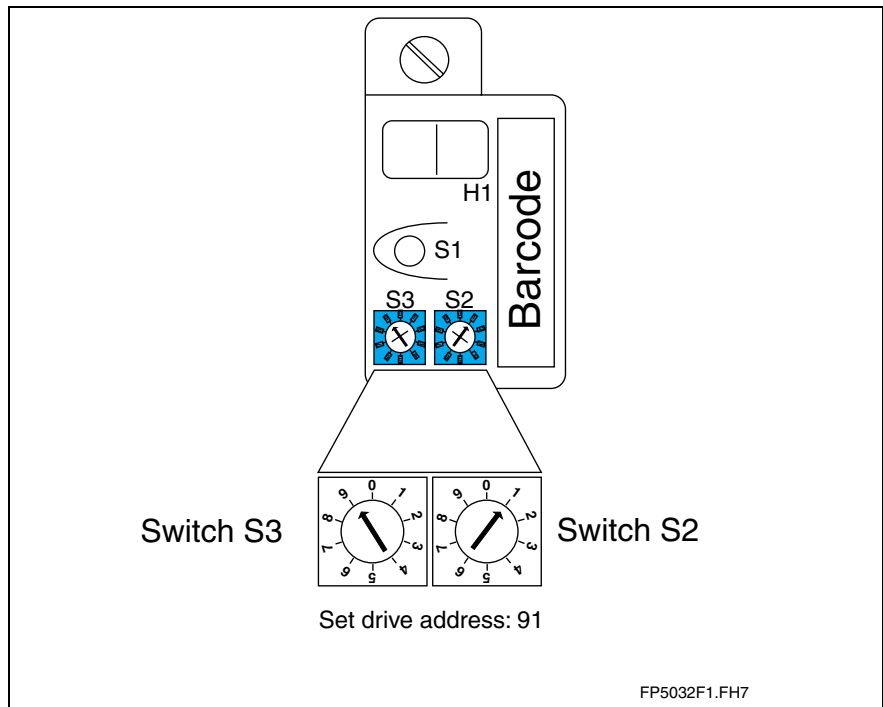

Fig. 4-109: Setting the drive address using a decade switch

Note: The address is not set at delivery.
The setting of switches S2 and S3 depends on the model, firmware and the drive address wanted.

⇒ See firmware functional description.

X8, Encoder 2

Technical description of connector

Illustration:

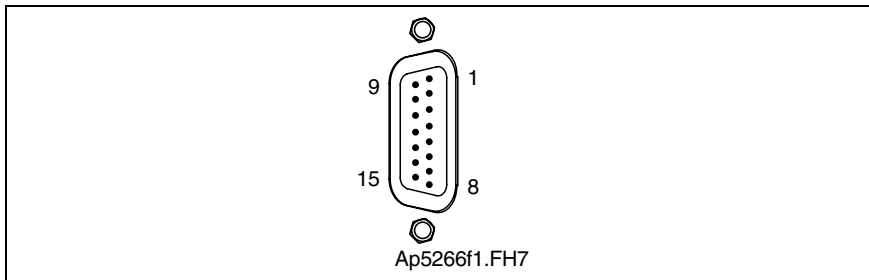

Fig. 4-110: Connector X5

Design:

Type	No. of pins	Design
D-SUB	15	Pins on unit

Fig. 4-111: Design

Connection cross section:

Cross section single wire [mm ²]	Cross section multi core wire [mm ²]	Cross section in AWG gauge no.:
--	0.25-0.5	--

Fig. 4-112: Connection cross section

Encoder 2

Connection Encoder 2:

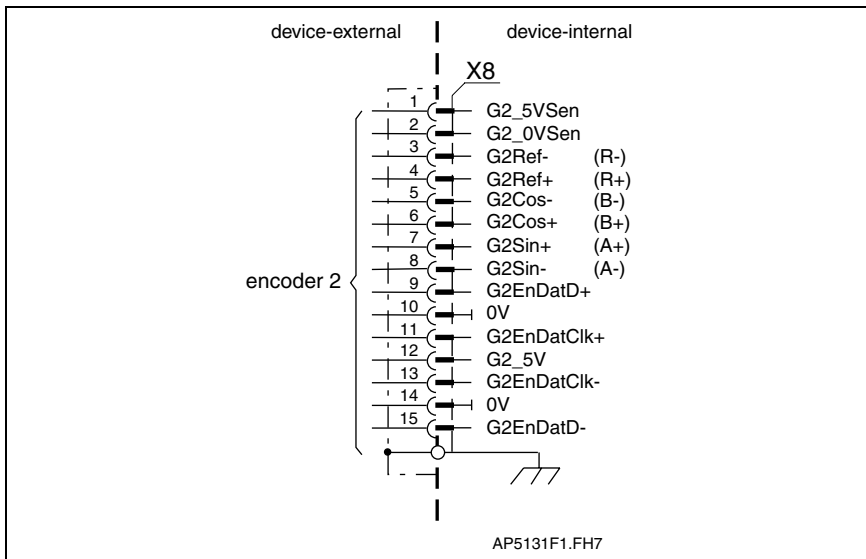

Fig. 4-113: Encoder 2

Shield connection: Via D-subminiature mounting screws and metal connector housing.

G2EnDat+, G2EnDat-: Differential signal of the EnDat Data lead.

G2EnDatClk+, G2EnDatClk-: Differential signal of the EnDat Pulse lead.

G2Sin+ (A+), G2Sin- (A-): Input circuit for sine signals G2Sin+ (A+), G2Sin- (A-):

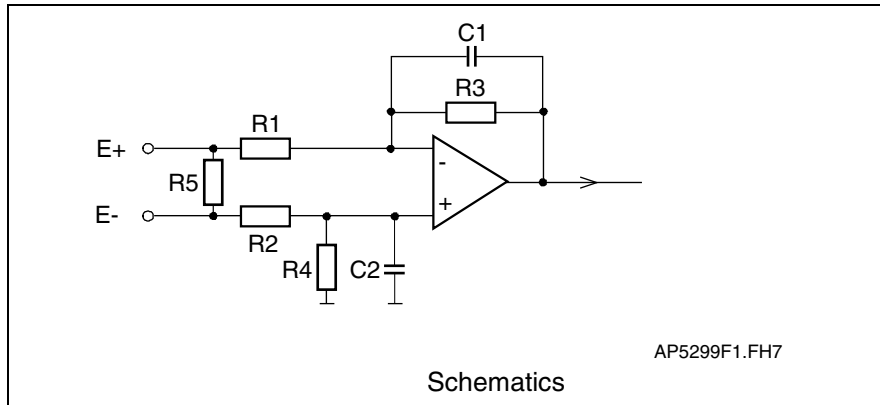

- R1: no data
- R2: no data
- R3: no data
- R4: no data
- R5: 120R
- C1: no data
- C2: no data

Fig. 4-114: Input circuit for sine signals

Input circuit for square-wave signals G2Sin+ (A+), G2Sin- (A-):

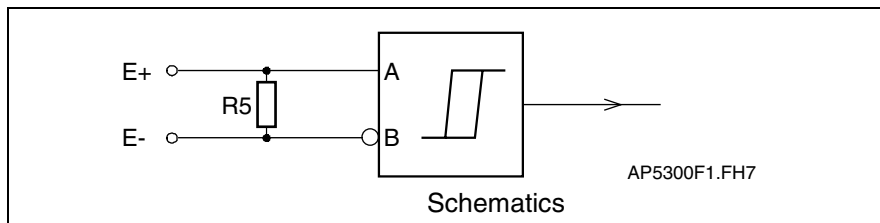

- R5: 120R

Fig. 4-115: Input circuit for square-wave signals

Features of the differential input G2Sin+ (A+), G2Sin- (A-):

Sine encoder:

	Input voltage
max. allowed amplitude encoder signal ($U_{S\text{Encoder signal}}$)	(1,0 + 0,2) V _{SS}
Evaluation AD converter	12 Bit
Limit frequency	200 kHz
Input resistance	120 R
Resolution over a encoder cycle	See the following note

Fig. 4-116: Features of the differential input (Sine encoder)

Note: Resolution over a period under the assumption of the following conditions:

- Differential signal $1.0V_{SS}$
- Reference voltage for the differential signal $2.7 V$

$$\bullet \frac{\text{Position resolution}}{\text{Encoder cycle}} = \frac{2^{12}}{1,2V_{SS}} \bullet U_{S\text{Encoder signal}}$$

Example: If $U_{S\text{Encoder signal}} = 1 V_{SS}$

$$\frac{\text{Position resolution}}{\text{Encoder cycle}} = \frac{2^{12}}{1,2V_{SS}} \bullet 1V_{SS} = 6826$$

=> see also firmware functional description "Optional encoder" (Encoder 2)

Square-wave encoder

	Input voltage	
Signal amplitude nominal: (referencing unit ground)	min.	max.
High	> 2.4 V	5 V
Low	0 V	< 0,8 V
Limit frequency	200 kHz	
Input resistance	120 R	

Fig. 4-117: Features of the differential input (Square-wave encoder)

G2Ref+ (R+), G2Ref- (R-): See "G2Sin+ (A+), G2Sin- (A-):"

G2Cos+ (B+), G2Cos- (B-): See "G2Sin+ (A+), G2Sin- (A-):"

G2_5VSen, G2_0VSen: Returning encoder supply to amplifier so that encoder cable can be regulated and 5V are pending at the encoder independent of cable length.

G2_5V: Features of the encoder output amplifier stage G2_5V:

Output voltage:	5 V _{DC}
max. output current:	300 mA

Fig. 4-118: Features of the encoder output amplifier stage

Signal allocation to the actual position value







Signal allocation (X8)	signal designation	signal form	actual position value (with default setting)
	G2Sin+(A+)  G2Sin- (A-)  G2Cos+(B+)  G2Cos- (B-)  G2Ref+(R+)  G2Ref- (R-) 	sine (1V _{ss}) without absolute value (e.g. gearwheel encoder)	reducing
	G2Sin+(A+)  G2Sin- (A-)  G2Cos+(B+)  G2Cos- (B-)  G2Ref+(R+)  G2Ref- (R-) 	square (TTL) without absolute value	reducing
	G2Sin+(A+)  G2Sin- (A-)  G2Cos+(B+)  G2Cos- (B-) 	sine (1 V _{ss}) with absolute value (e.g. EnDat)	increasing

Fig. 4-119: Signal allocation to the actual position value

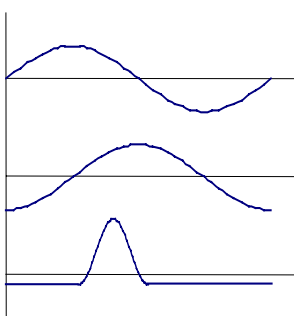
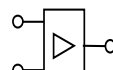
Note: Default setting:
 => see firmware functional description "Optional encoder" (Encoder 2)

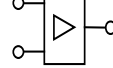
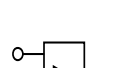
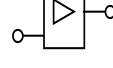
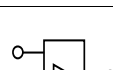
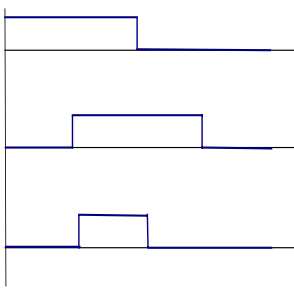
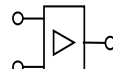
Allowed encoder cable lengths

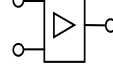
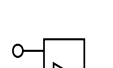
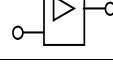
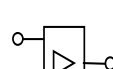
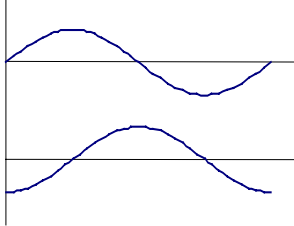
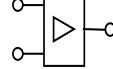
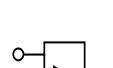
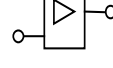
Selecting wire cross sections

Note: The current consumption of the connected encoder systems generates a voltage drop due to the resistivity (dependent upon the wire cross sections and lengths) of the wire. This reduces the signal at the encoder input.

To compensate the voltage drop, the DKC can influence the encoder power source. Using a voltage sensor, the available voltage at the encoder is known.

⇒ For a given wire length and encoder current consumption, a minimum cross section becomes necessary. This relationship is illustrated below.

1. With sensor connection in the encoder lead

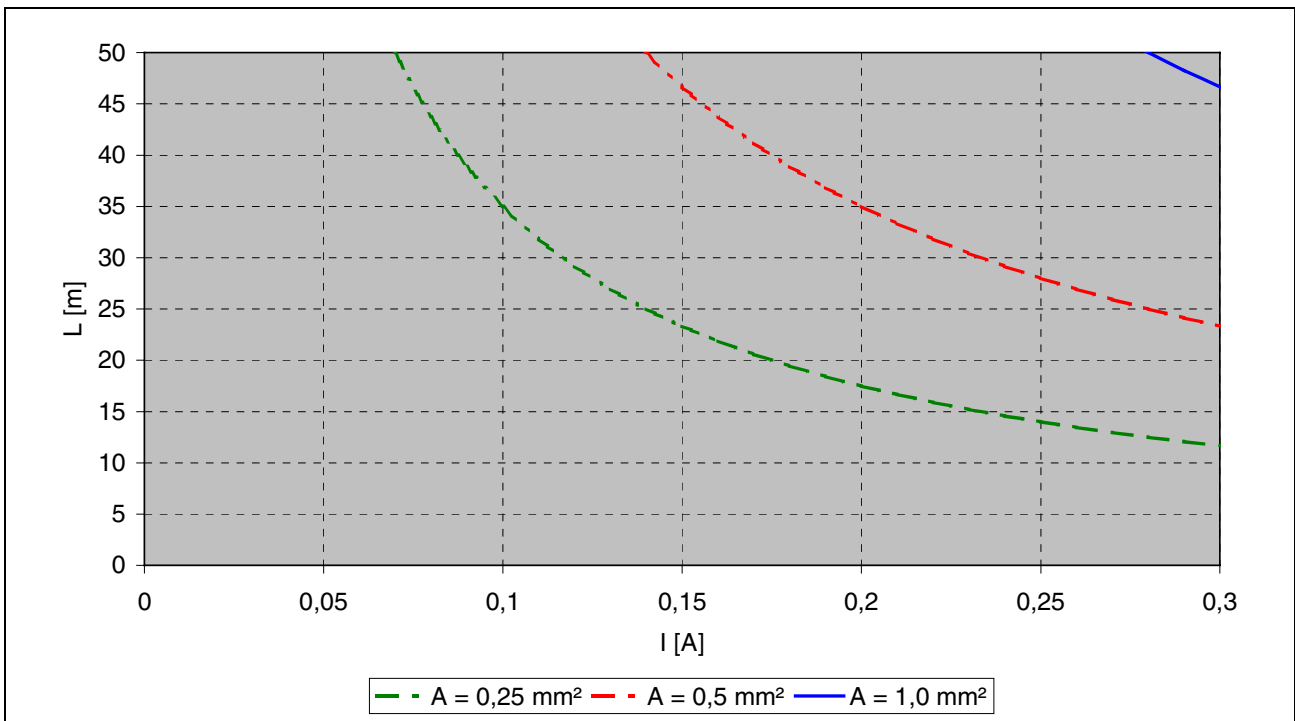

L: cable length
 I: current
 A: wire cross sections

Fig. 4-120: With sensor connection

2. Without sensor connection in the encoder lead

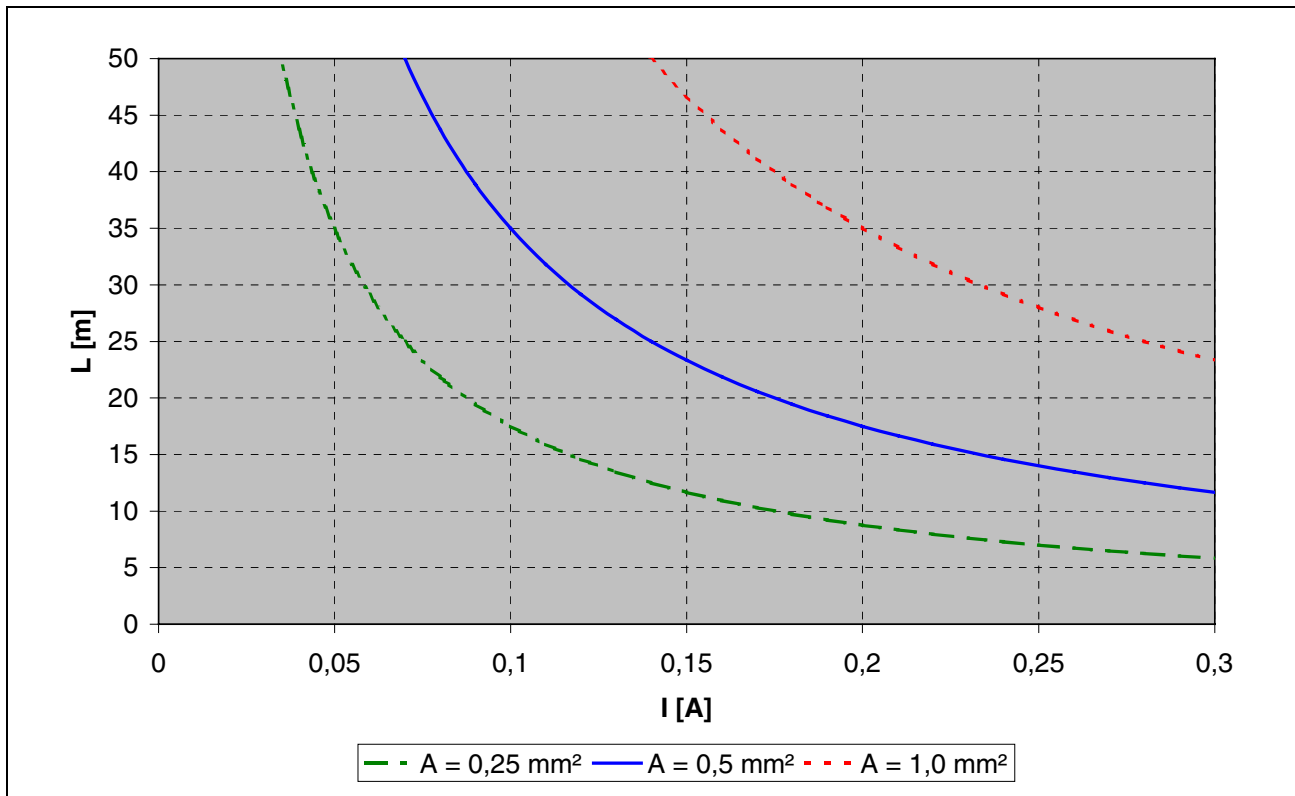

L: cable length
 I: current
 A: wire cross sections

Fig. 4-121: Without sensor connection

Measuring Systems Connections

See page 1-4: "An Overview of Measuring Systems Supported".

X9, Incremental and Absolute Encoder Emulation (SSI format)

Technical description of connector

Illustration:

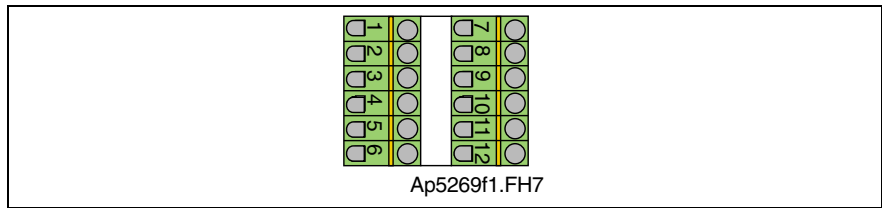

Fig. 4-122: Connector X9

Design:

Type	No. of pins	Design
Spring contact	2 x 6	Bushing on connector

Fig. 4-123: Design

Connection cross section:

Cross section single wire [mm ²]	Cross section multi core wire [mm ²]	Cross section in AWG Gauge no.:
0.2-2.5	0.2-1.5	24-16

Fig. 4-124: Connection cross section

Connection encoder - emulation

Cable:

max. cable length:	40 m
max. allowed capacitance per length unit – between the outputs – between output and 0 V	5 nF 10 nF
shielding see also "Fig. 4-125: Connection of incremental actual position value output" and "Fig. 4-129: Output of absolute actual position value in SSI format"	double shield protected



CAUTION

Damaging potential by utilizing non and single shielded cables.

⇒ Utilize double shielded cables.

Encoder - emulation

Note: The output of the actual position value is updated every 500 μs. Due to the non synchronized processing of these signals in the controller sampling inaccuracies and beat effects arise.

Incremental encoder emulation

Connection
Incremental encoder emulation:

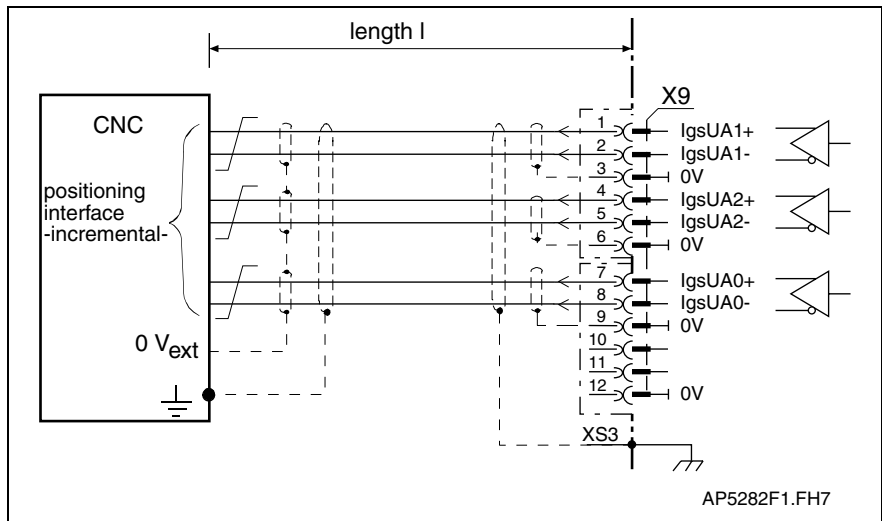

Fig. 4-125: Connection of incremental actual position value output

Differential outputs incremental encoder emulation:

Output voltage:	min.	max.
High	2.5 V	5 V
Low	0 V	0.5 V
max. output current I_{out}	1201 mA	
max. load capacitance between output and 0 V	10 nF	
max. output frequency f	1 MHz	
Overload protection	Outputs may not be short circuited. Danger of damage!	

Fig. 4-126: Differential outputs

Note: The differential outputs correspond to RS422 specs. A termination resistor is required on the controller side, if it is not present then add an external resistance of 150 - 180 Ohm.

Signal for incremental actual position value output:

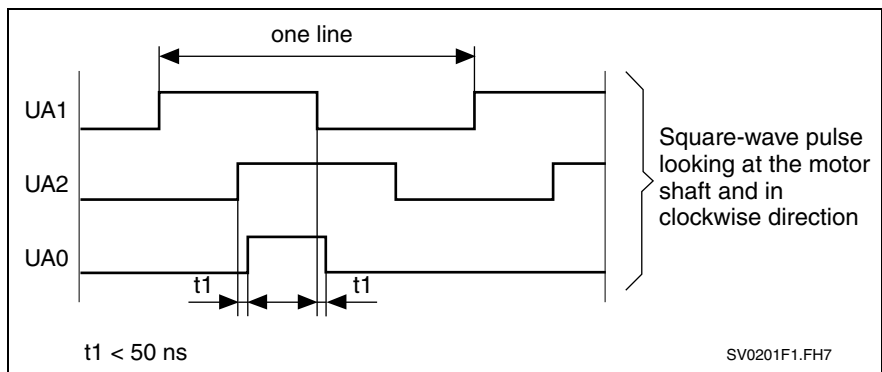

Fig. 4-127: Signal for incremental actual position value output

Output frequency f:

$$f = \frac{\text{Line Quantity}}{\text{Revolutions}} \cdot n$$

f: output frequency
n: velocity (rotary)

Fig. 4-128: Calculating the output frequency f

Note: The output frequency results from the parameter setting.
=> See also firmware functional description: "Encoder Emulation".

Pass-band width of the controller-side signal filtering for UA1 and UA2::

Note: Conditionally due to the internal signal processing the period duration and the duty cycle of the signals put out vary. Therefore the following requirements of the signal filtering for UA1 and UA2 arise.

- $f \geq 500 \text{ kHz}$ $f_{\text{Pass}} \geq 1 \text{ MHz}$
 - $f < 500 \text{ kHz}$ $f_{\text{Pass}} \geq 2 \times f$
-

RPM Measurement:

Note: The frequency measurement is **not** suitable for the RPM measurement derived from the incremental emulator signals.

Absolute Encoder Emulation (SSI format)

**Connection
Absolute Encoder Emulation:**

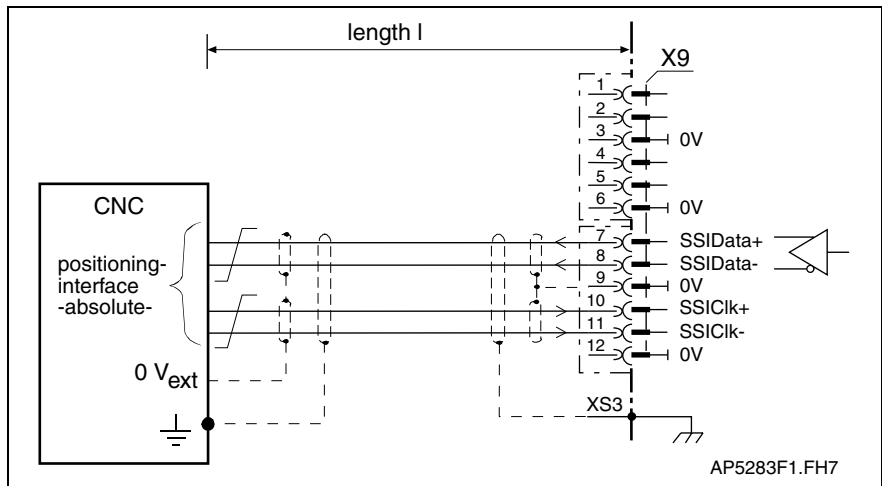
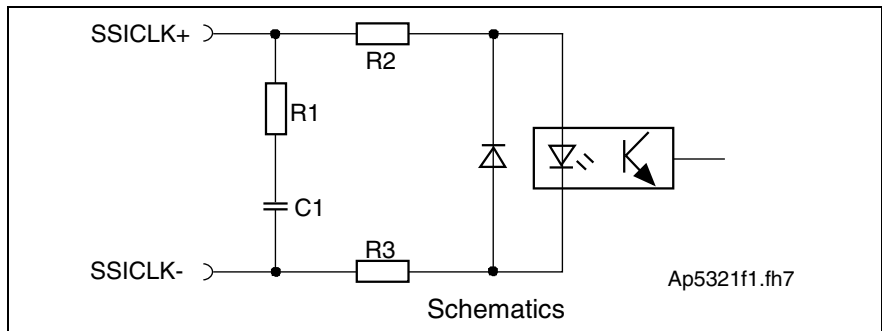

Fig. 4-129: Output of absolute actual position value in SSI format

**Differential input circuit
absolute encoder emulation:**



- R1: 332R
- R2: 100R
- R3: 100R
- C1: 1nF

Fig. 4-130: Differential input circuit

**Differential inputs
absolute encoder emulation:**

Input voltage:	min.	max.
High	2.5 V	5 V
Low	0 V	0.5 V
Input resistance	see circuit	
Pulse frequency	(100 – 1000 kHz)	
Polarity protected within allowable input voltage range		

Fig. 4-131: Differential outputs

**Differential outputs absolute
encoder emulation:**

See "Fig. 4-126:Differential outputs".

Note: The differential outputs correspond to RS422 specs. A termination resistor is required on the controller side, if it is not present then add an external resistance of 150 - 180 Ohm.

Pulse diagram for absolute actual position output (SSI format)

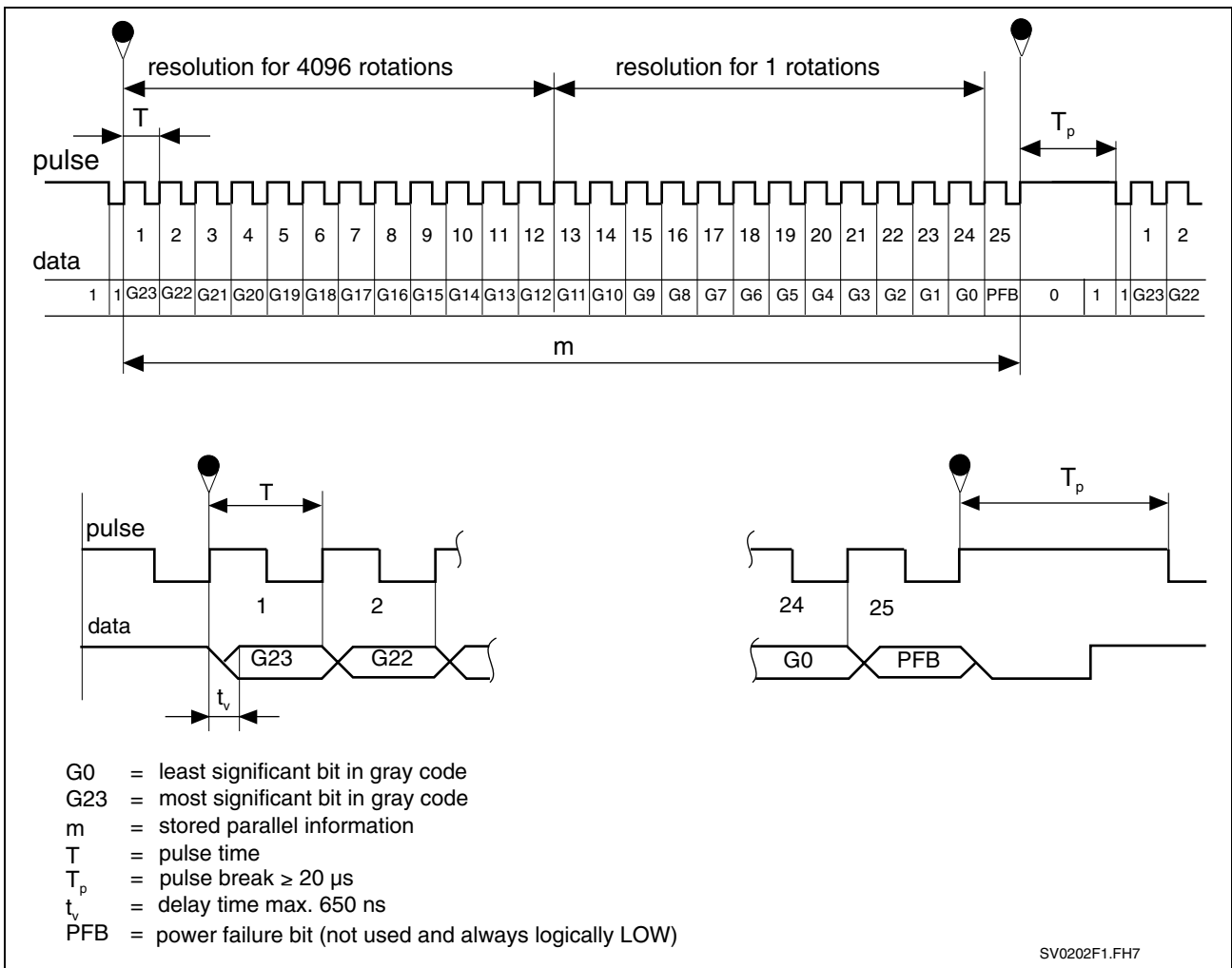

Fig. 4-132: Pulse diagram for absolute actual position output (SSI format)

X10, EcoX Expansion interface

Note: EcoX allows:

- synchronizing drives and I/O modules
- connecting up to 2 modules with 16 digital inputs and outputs each per drive controller
- transmitting a command value from one drive controller to a maximum of three other drive controllers

Technical description of connector

Illustration:

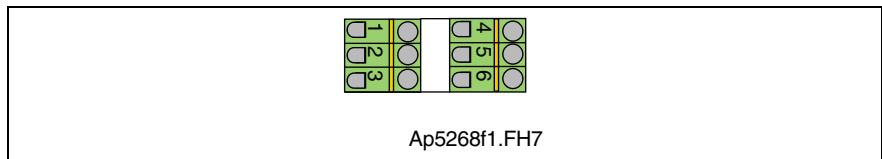

Fig. 4-133: Connector X10

Design:

Type	No. of pins	Design
Spring contact	2 x 3	Bushing on connector

Fig. 4-134: Design

Connection cross section:

Cross section single wire [mm ²]	Cross section multi core wire [mm ²]	Cross section in AWG gauge no.:
0.2-2.5	0.2-1.5	24-16

Fig. 4-135: Connection cross section

Expansion interface

Connection
Expansion interface:

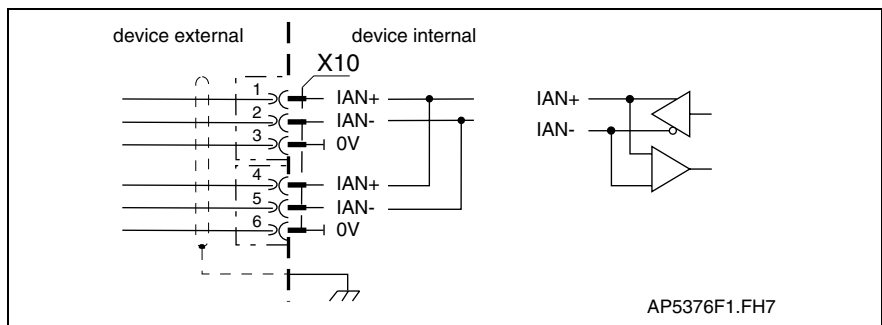

Fig. 4-136: Expansion interface

EcoX-Bus:

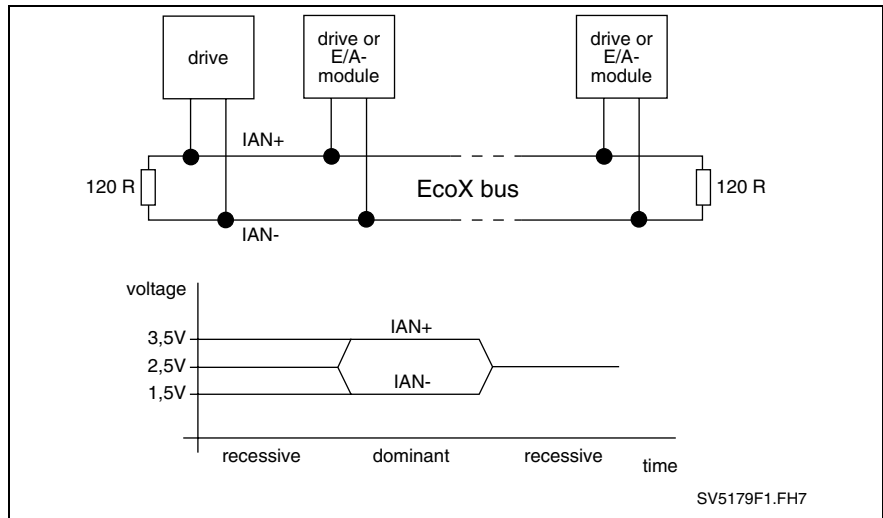

Fig. 4-137: EcoX interface

Bus cable:	max. bus length l:	20 m
	bus terminating resistors on both ends of the bus cable	2 x 120 R / 250 mW

⇒ see also Project Planning Manual "EMD Module Decentral Additional Component for Digital Drive Controllers".
 Dok.-Type: DOK-DRIVE*-ECOX*****-PRxx-EN-P

X11, DC bus dynamic brake (ZKS), U_D power supply

Technical description of connector

Illustration:

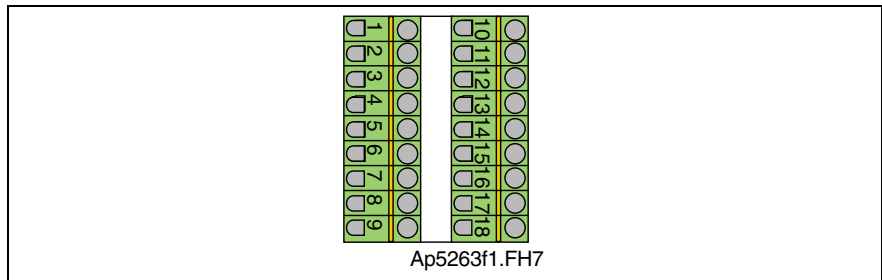

Fig. 4-138: Connector X11

Design:

Type	No. of pins	Design
Spring contact	2 x 9	Bushing on connector

Fig. 4-139: Design

Connection cross section:

Cross section single wire [mm ²]	Cross section multi core wire [mm ²]	Cross section in AWG Gauge no.:
0.2-2.5	0.2-1.5	24-16

Fig. 4-140: Connection cross section

ZKS control supply

Note: Internal DC bus dynamic brake setup (ZKS) not in DKC**.3-040-7-FW.

Connection
+24Vpro and 0V:

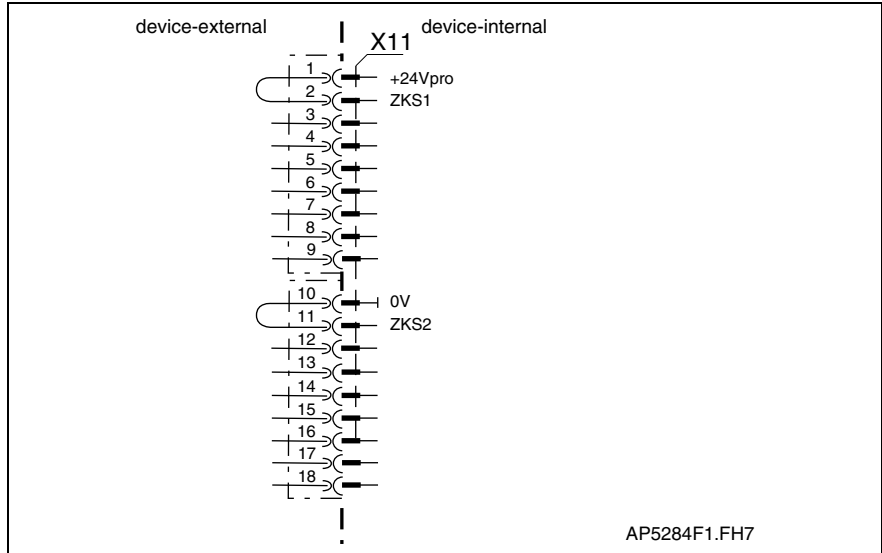
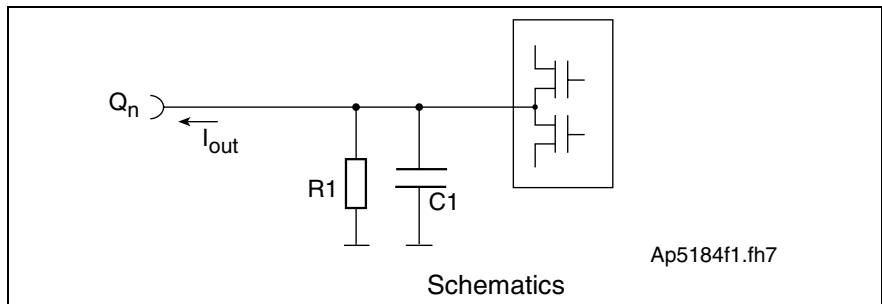

Fig. 4-141: DC bus dynamic brake control

At delivery: with bridges at:

X11.1 to X11.2
X11.10 to X11.11

Output
+24Vpro:



R1: approximately 12 R
C1: 470 μ F

Fig. 4-142: Voltage source from X2.1

Loadability of the connection
+24Vpro:

max. output voltage (dependent of control voltage an X1.1)	DC (19.2...28.8) – 2 V
max. allowed output current:	DC 0.1 A
Thermal overload protection	via charging current limiter behind X1.1
max. short circuit current	2.4 A

Application
+24Vpro:

The connections supported the ZKS inputs.

ZKS control input

Connection
ZKS1 and ZKS2:

See page 4-89: "ZKS control supply".

Input circuit
ZKS1 and ZKS2:

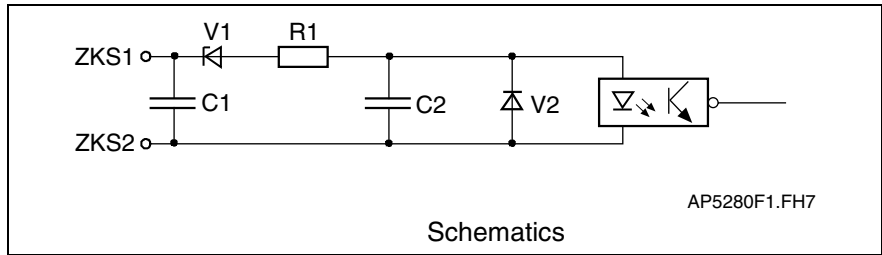

- R1: 2k2
- V1: 10V
- V2: 0.7V
- C1: 0.1µF
- C2: 0.1µF

Fig. 4-143: Input circuit

Inputs
ZKS1 and ZKS2:

Input voltage:	min.	max.
High	15 V	28.8 V
Low	0 V	4 V
trigger delay t_d due to contactor drop delay	min. 40 ms	max. 80 ms
Input resistance	about 2 kOhm	
Potential isolation	to 50 Veff	
Polarity protected within allowed input voltage range		

Fig. 4-144: Inputs

Use
ZKS1 and ZKS2:

The connections supply the ZKS input and permit potential free control of DC bus dynamic brake setup via a relay contact.

Trigger behavior of DC bus setup:

Mains voltage at X5	DC input	DC bus setup
not applied	no current	active
not applied	current	not active
applied	not current	not active
applied	current	not active

Fig. 4-145: Trigger behavior of ZKS setup

Protecting the ZKS setup with mains voltage applied:

Note: If mains voltage applied at X5 then DC bus dynamic brake not executed! The ZKS control is realized with the currentless input.

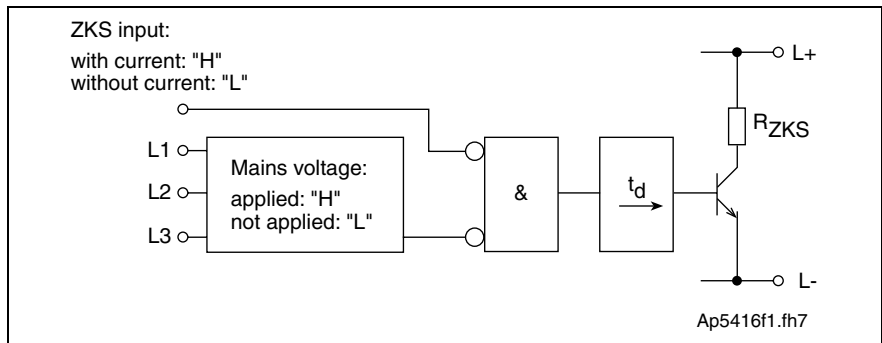

Fig. 4-146: Block diagram interlock ZKS/Mains

See page 4-25: "Arranging the Central supply" and page 11-5: "Control Circuits with internal DC bus dynamic brake (ZKS)".

U_D power supply

Connection U_D mains section:

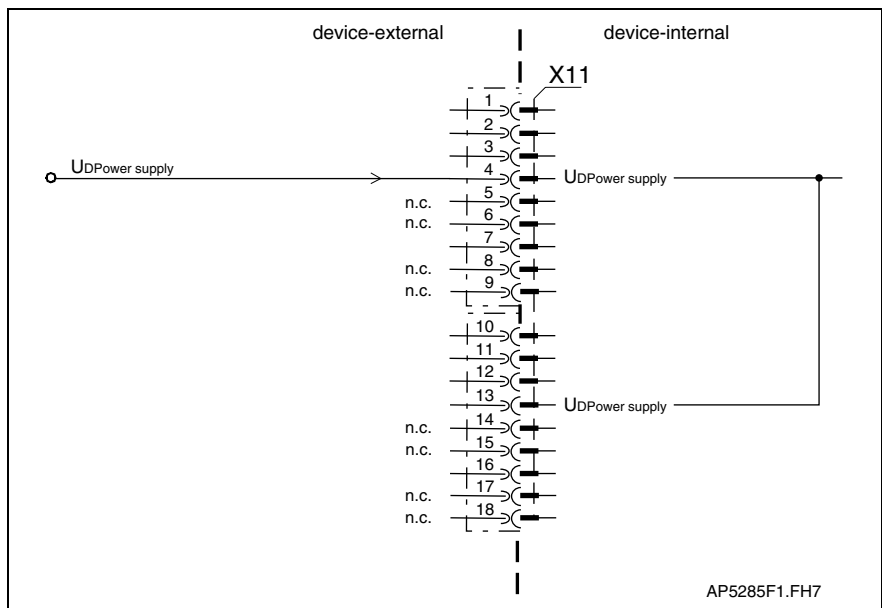

Fig. 4-147: Bb drive, Bb power supply and U_D power supply

Input circuit U_D mains section:

See page 4-47: "Drive halt (AH) and Drive enable (RF)".

Inputs See page 4-47: "Drive halt (AH) and Drive enable (RF)".
U_D power supply:

U_D power supply: With central mains supply (see page 4-25: "Arranging the Central supply") the DKC's operated on one DC bus must be informed about the status of the power supply.

The output U_{Dmessage} (X3.11) is high, upon completion DC bus load.

With this type of mains supply, the U_D-message X3.11 serves as a signal source to the DKC's connected to the mains supply.

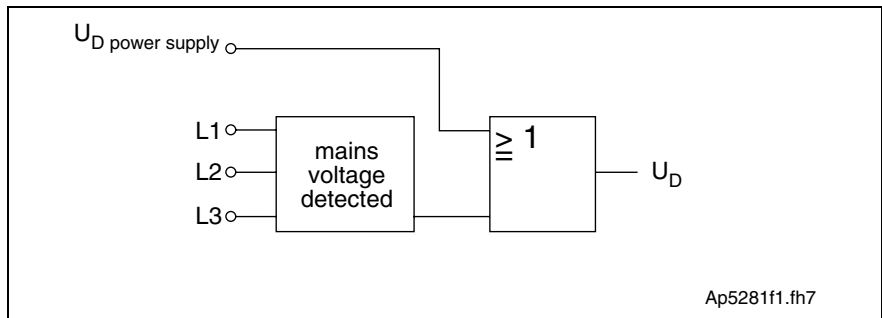

Fig. 4-148: Correlation of U_D power supply and U_D (U_D message)

See page 4-55: "Digital outputs (ready, warning and UD)".

Connection U_D power supply:

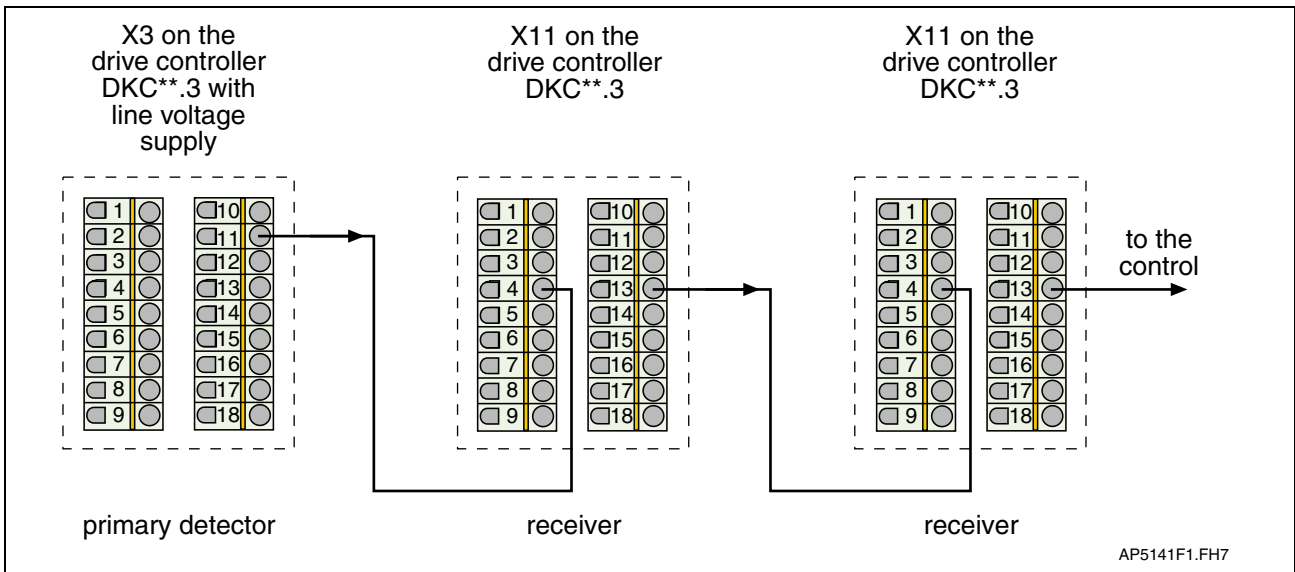

Fig. 4-149: U_D power supply

X12, Optional Choke Connection for DKC**.3-200-7

Technical description of connector

Illustration:

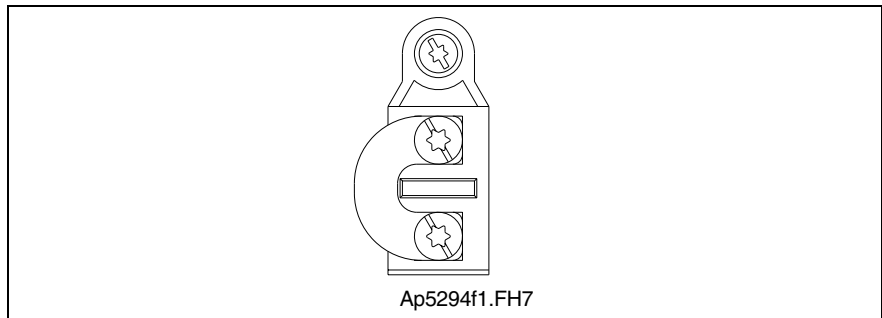

Fig. 4-150: Connector X12

Design:

Type	No. of pins	Design
Screw-in connector	2	screw-in connection for ring terminals M5

Fig. 4-151: Design

Tightening torque:

min. tightening torque [Nm]	max. tightening torque [Nm]
2.5	3.0

Fig. 4-152: Tightening torque

Connection cross section:

Cross section single wire [mm ²]	Cross section multi core wire [mm ²]	Cross section in AWG Gauge no.:
--	10 - 25	--

Fig. 4-153: Connection cross section

Connection Choke (DR+, DR-)

Connection DR+, DR-:

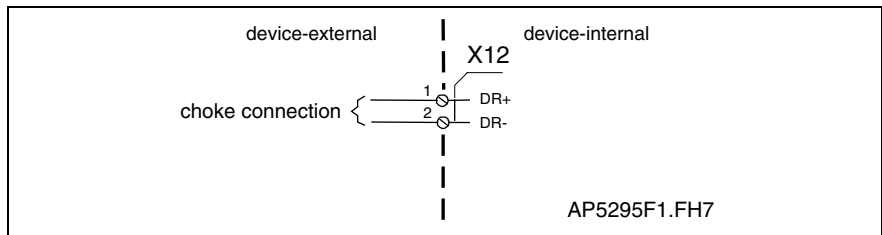

Fig. 4-154: Optional choke connection for DKC**.3-200-7

At delivery: with bridges at: X12.1 to X12.2

Loadability of the connection DR+, DR-:

max. voltage against L-:	DC 900 V
voltage against ground	Applied mains voltage
max. continuous current (rms):	70 A

Wire DR+, DR-:	wire length:	max. 10 m
	wire cross section:	min. 10 mm ² , but not smaller than mains wire cross section
	wire routing	twisted
	voltage resistance of single litz to ground:	≥ 750 V (e.g.: litz wires - H07)

Note: Connection bridged at delivery.

Choke type: See page 8-1: "Choke GLD 12".

XE1, XE2 Protective conductor connections for motor and mains

Technical description of connector

Illustration: See page 4-40: "A look at the drive controller and connector designations".

Design:	Type	No. of pins	Design
	screw-in connection	1	screw-in connection for ring terminals M5

Fig. 4-155: Design

Tightening torque:	min. tightening torque [Nm]	max. tightening torque [Nm]
	2.5	3.0

Fig. 4-156: Tightening torque

Connection cross section:	Cross section single wire [mm ²]	Max. connectable cross section in mm ²	Max. cross section in AWG gauge no.:
	--	25	--

Fig. 4-157: Connection cross section

XE1, Protective conductor connection for motor

See page 4-64: "Motor connection".

XE2, Protective conductor connection for mains

Note: PE connection $\geq 10 \text{ mm}^2$
Reason: high leakage currents (EN 50178/1998, section: 5.3.2.1)

XS1, XS2, XS3 Shield Connections

XS1

Connection for shield:

- Total motor cable shield
- Holding brake
- Motor temperature monitoring
- Mains supply

XS2

Connection for shields of cables at X1, X3 and those for the command communication interfaces.

XS3

Connection for shields of cables at X9, X10 and X11.

Allowed outside diameters:

Drive controller	XS1	XS2	XS3
DKC**.3-040	12-18	6-15	6-15
DKC**.3-100	12-35	6-15	6-15
DKC**.3-200	19-35	6-15	6-15

Fig. 4-158: Allowed outside diameters in mm

Note: Always connect the shield connections of the cables (especially of the motor cables) with a large contact surface.

4.3 Electrical Connections – dependent on the drive controller type

DKC 01.3-***-7-FW – Parallel Interface

View of interface to command communications

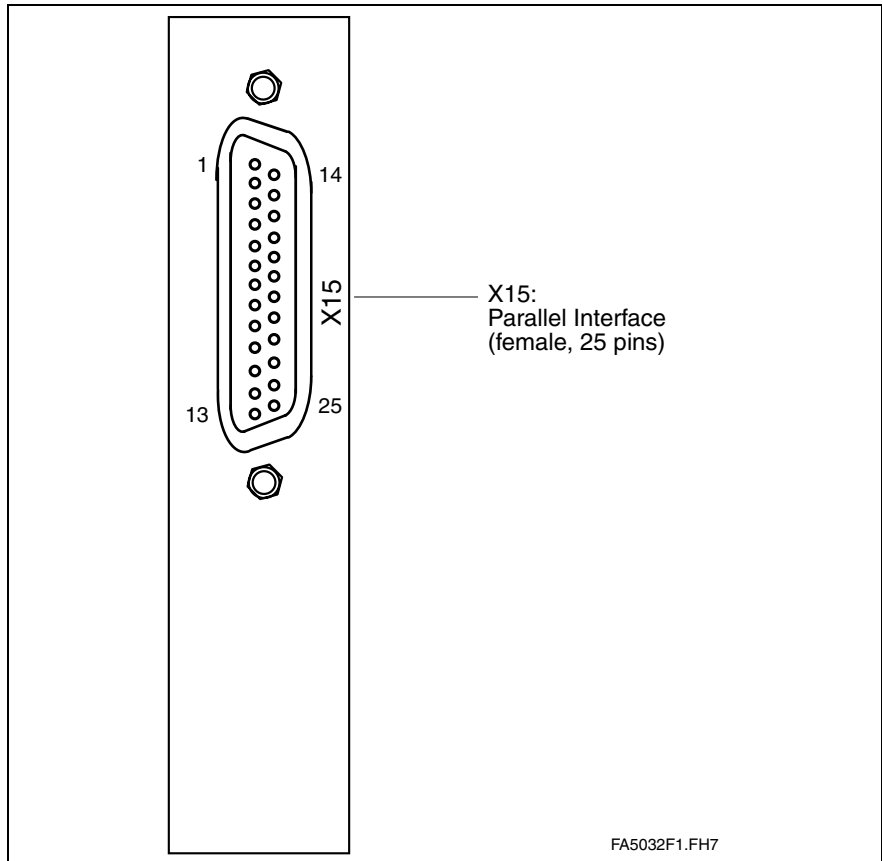

Fig. 4-159: View of interface to command communications

Technical description of connector

Design:	Type	No. of pins	Design
	D-SUB	25	Bushing on the unit

Fig. 4-160: Design

Connection cross section:	Cross sections single wire [mm²]	Cross sections multi core wire [mm²]	Cross sections in AWG gauge no.:
	--	0.08-0.5	--

Fig. 4-161: Connection cross sections

Connection diagram for Parallel Interface

Note: If a power supply other than the DC24 volts of the DKC controls the inputs, then connect the standard lead (GND) of the separate mains section to X15.13 (0 V).

**Connection
Parallel Interface:**

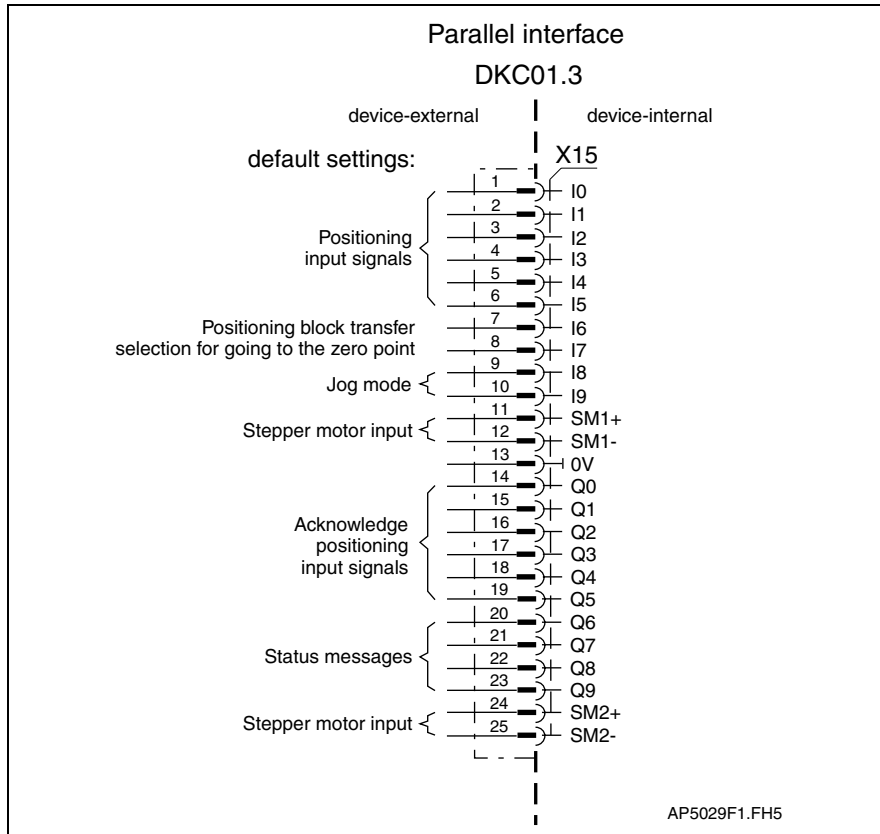

Fig. 4-162: Parallel interface for DKC01.3

**Plug-in connector assignment
X15:**

Pin	IO	Function	Pin	IO	Function
1	I	I 0	14	O	Q 0
2	I	I 1	15	O	Q 1
3	I	I 2	16	O	Q 2
4	I	I 3	17	O	Q 3
5	I	I 4	18	O	Q 4
6	I	I 5	19	O	Q 5
7	I	I 6	20	O	Q 6
8	I	I 7	21	O	Q 7
9	I	I 8	22	O	Q 8
10	I	I 9	23	O	Q 9
11	SM1+	Diff input+	24	SM2+	Diff input+
12	SM1-	Diff input-	25	SM2-	Diff input-
13	0V	0V	--	--	--

Fig. 4-163: Signal assignment X15

Shield connection: Via D-subminiature mounting screws and metal connector housing.

Default allocation of the binary I/Os:

Pin	Inputs	Pin	Outputs
1	I 0	14	Q 0
2	I 1	15	Q 1
3	I 2	16	Q 2
4	I 3	17	Q 3
5	I 4	18	Q 4
6	I 5	19	Q 5
7	I 6	20	Q 6
8	I 7	21	Q 7
9	I 8	22	Q 8
10	I 9	23	Q 9
13	0V		

Fig. 4-164: Default allocation of I/Os

Note: The I/O allocation can be configured.
=> See firmware functional description.

Input circuit I 0 – I 9:

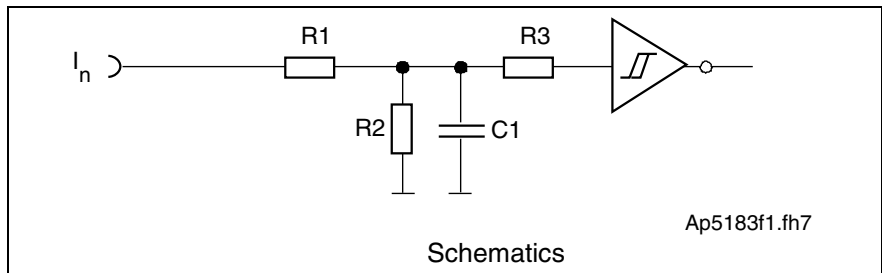

- R1: 10k
- R2: 3k3
- R3: 10k
- C1: no data

Fig. 4-165: Input circuit

Signal range of inputs I 0 – I 9:

Input voltage:	min.	max.
High	16 V	30 V
Low	-0.5 V	3 V
Input resistance	13.3 kOhm ±5%	
reaction time	=> see firmware functional description	

Fig. 4-166: Inputs

**Output circuit
Q 0 – Q 9:**

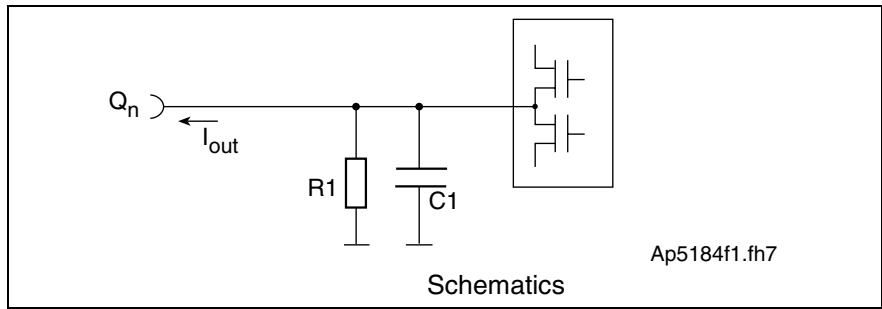

R1: 20k
C1: no data

Fig. 4-167: Output circuit

**Signal level of outputs
Q 0 – Q 9:**

Output voltage:	min.	max.
High	16 V	$U_{ext} (an X1.1-1V) - 1.5 V$
Low	-0.5 V	
Output current I_{out}	80 mA	
rise and drop time	about < 600 ns	
overload protection	- short circuit protection; at $I_{out} > 300 mA$ outputs switch off - thermal off	

Fig. 4-168: Outputs

**Default allocation of step-motor
inputs:**

Pin	Inputs		Pin	Outputs	
11	SM1+	Diff input	24	SM2+	Diff input
12	SM1-	Diff input	25	SM2-	Diff input

Fig. 4-169: Default allocation of step motor inputs

The stepper motor inputs are galvanically isolated from the drive controller. They function as differential inputs to process RS422 compatible signals.

**Stepper motor inputs
SM1+, SM1-, SM2+, SM2-
Circuit:**

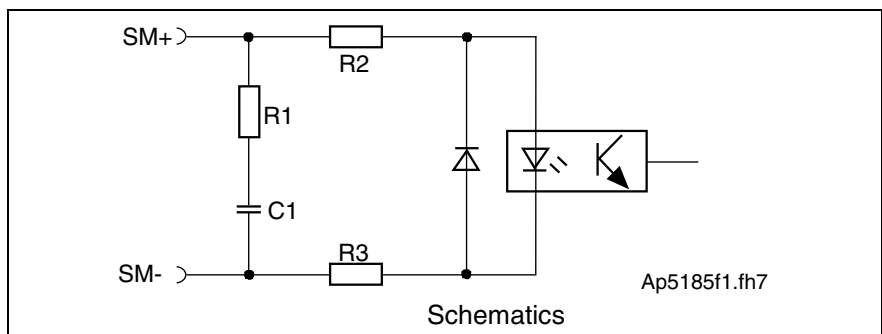

R1: 121R
R2: 121R
R3: 121R
C1: 1 nF

Fig. 4-170: Differential input circuit

Signal voltages of differential inputs:

Input voltages	min.	max.
Difference:	3 V	5 V
input current:	min.	max.
	5 mA	15 mA
cycle frequency	max. 1 MHz	

Fig. 4-171: Differential inputs



CAUTION

Overloads destroy inputs!

⇒ Maximum input current may not be exceeded.

Control inputs for jog mode (Jog+, Jog-)

Jog+, Jog-: The axis can be moved positively or negatively in jog mode by using the jog+ and jog- inputs.

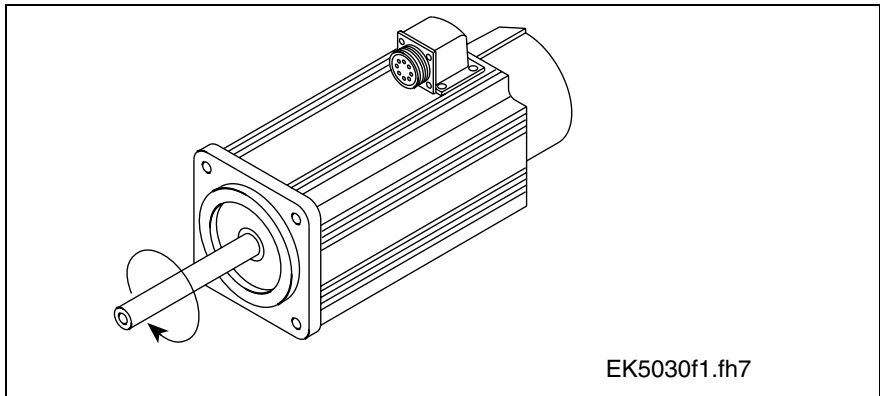

Fig. 4-172: Rotational direction with jog+

View from front of the output drive side, arrow indicates positive direction.

Inputs and outputs for positioning block mode

- I 0 – I 5:** Select leads (binary coded)
- I 6 – I 7:** Positioning block accept (start), selection to go to zero
- Q 0 – Q 5:** Select acknowledge leads (binary code)
- Q 6 – Q 9:** Status output

Control inputs for stepper motor mode (SM1+, SM1-, SM2+, SM2-)

Note: The control of the stepper motor interface with differential signals is preferable to single-channel control because the noise immunity of differential signals is better than zero-referenced signals.

**Connection
single channel:**

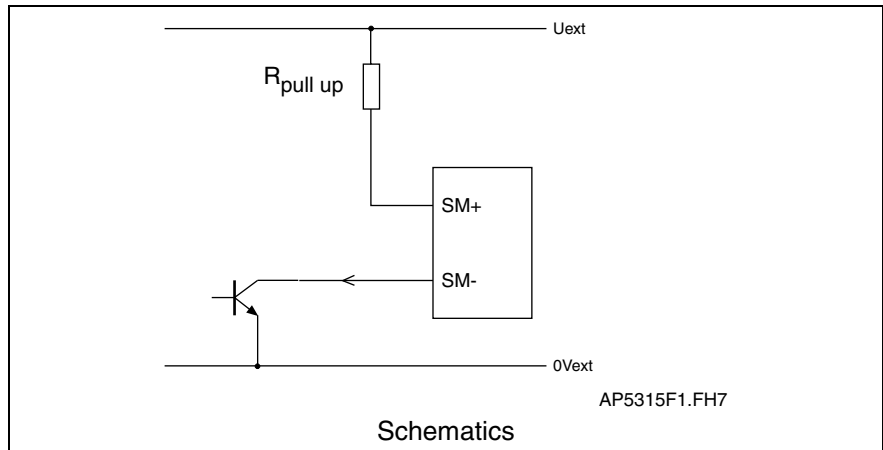

Fig. 4-173: Controlling with open collector outputs



CAUTION

Overloads damage inputs!

⇒ Resistance $R_{\text{pull up}}$ must be sized so that the maximum allowed input current is never exceeded.

Controlling with the stepper motor interface:

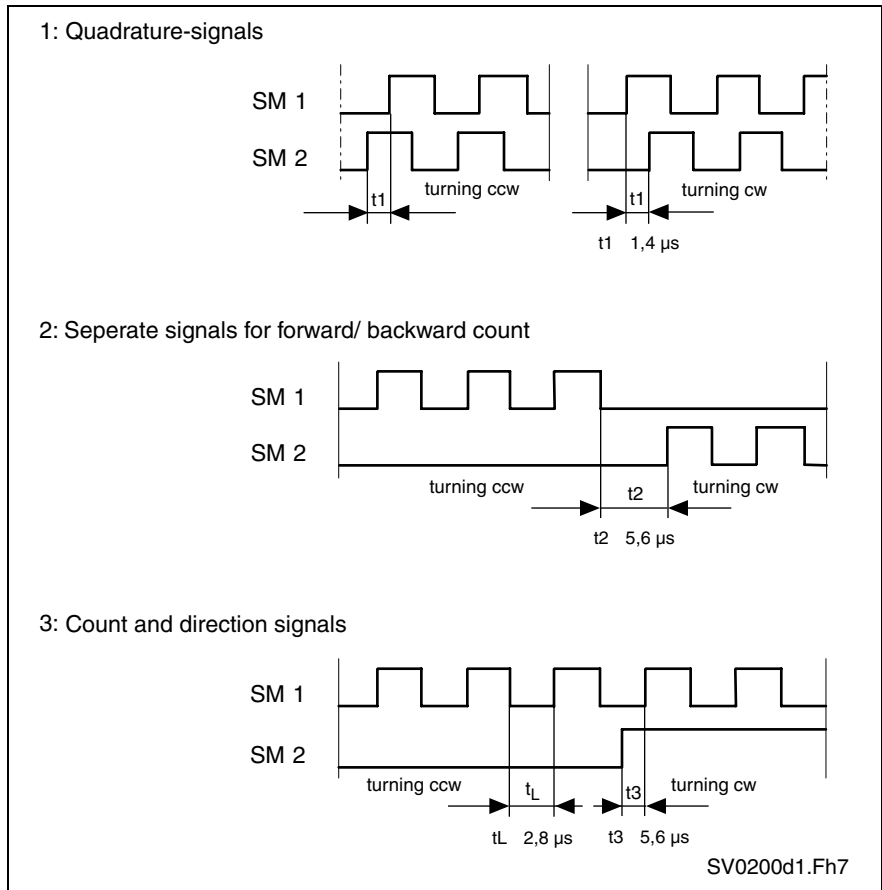

Fig. 4-174: Stepper motor interface types of control

Control with differential signals:

- Logic 1 is detected with a positive voltage difference of SM+ to SM-.
- Logic 0 is detected with a negative voltage difference of SM+ to SM-.
- To increase noise immunity the amplitude of the voltage difference should equal at least 3.0 volts. The greater the voltage difference, the better the noise immunity.

DKC 02.3-***-7-FW – SERCOS interface

View of command communication interface

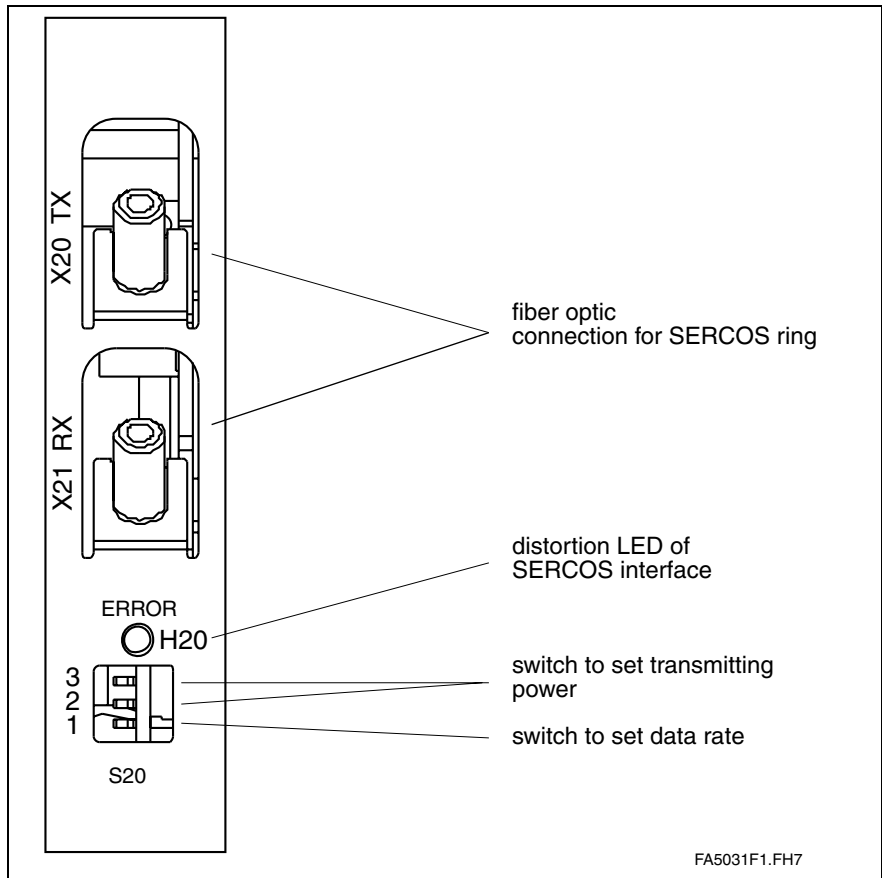

Fig. 4-175: View of command communication interface

Connection diagram for SERCOS interface

Connection
SERCOS interface:

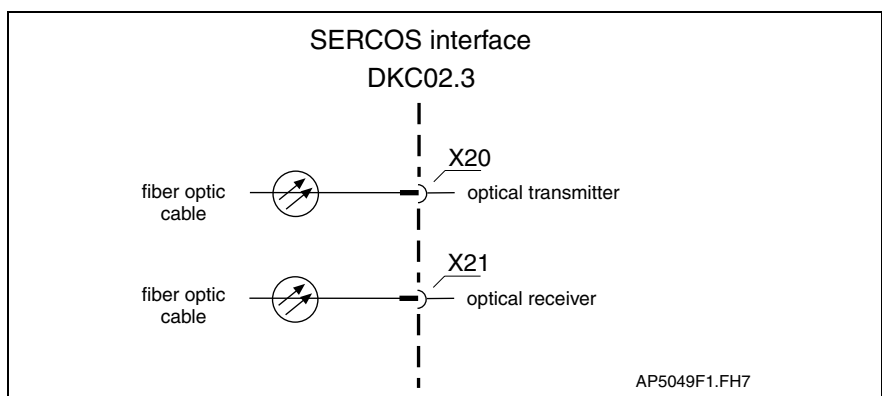

Fig. 4-176: I/O connection allocations for DKC02.3

Switch S20

Data rate, transmitter power The transmitter power and the data rate for the SERCOS interface are set with the switch S20.

The DKC is factory set to an average transmitter power (-4.5 dBm) and the lowest data rate(2 Mbit/s).

Position of switch The switches are in OFF position if the switch lever is facing the rear (rear panel). Switch S20/1 is down (see marking on the unit).

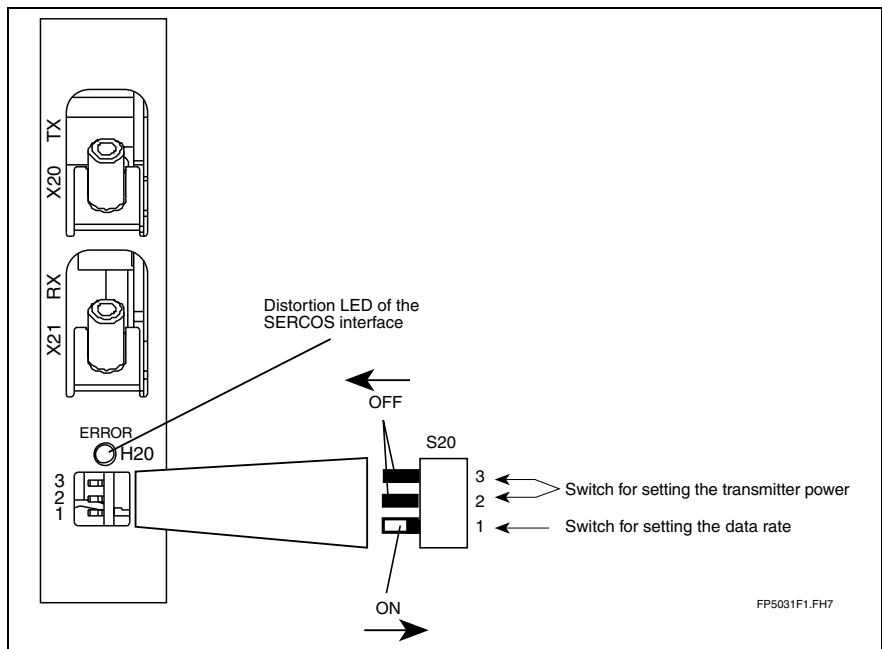

Fig. 4-177: Position of the switch for data rate and transmitter power demonstrating how to switch it ON and OFF

Data rate The data rate is set with the switch S20/1.

Position of switch S20/1	Data rate in Mbit/s
OFF	2
ON	4

Fig. 4-178: Relationship between switch position S20/1 and the data rate

Transmitter power The transmitter power is set with the switches S20/2 and S20/3.
The following table demonstrates the relationship between switch position and transmitter power.

Switch position S20/2	Switch position S20/3	Transmission power at optimum high level in dBm	Transmission power at optimum high level in μ W	Maximum length with plastic fiber optic (*1)	Maximum length with glass fiber optic (*1)
OFF	OFF	-7	200	0...15 m	--
ON	OFF	-4,5	350	15...25 m	--
OFF	ON	-1	800	25...35 m	--
ON	ON	0	1000	35...50 m	0...500 m

Fig. 4-179: Relationship between switch position S20/2, S20/3 and the data rate

(*1): The data for the maximum lengths of the fiber optic cable only apply if the following preconditions have been met:

- Rexroth Indramat fiber optic cables IKO 982, IKO985 or IKO 001 are used
- Connection without separation. If couplings are used, the maximum length for plastic fiber optic cables is reduced by about 10 meter, 100 meters for glass fiber optic cables.

Fiber optic cables

Drives with a SERCOS interface are connected to higher-level controls with a fiber optic cable.

The fiber optic cables (cables, connectors or complete leads) must be ordered separately.

For more information, see "Fiber optic cables" in application description "LWL-Handling" (DOK-CONN-CABLE*LWL-AWxx-EN-P).

"LWL-Handling" discusses:

- Fiber optics in general
- Basic plans for optical transmission systems
- Routing guidelines for fiber optic cables
- Attenuation readings of standard LWL cables
- Available fiber optic-FSMA plug-in connectors and fiber optic cables
- Guidelines on making an FSMA connector
- Tools for making fiber optic cables

Use the following illustration to find out which fiber optic cable to order.

Selecting fiber optic connections:

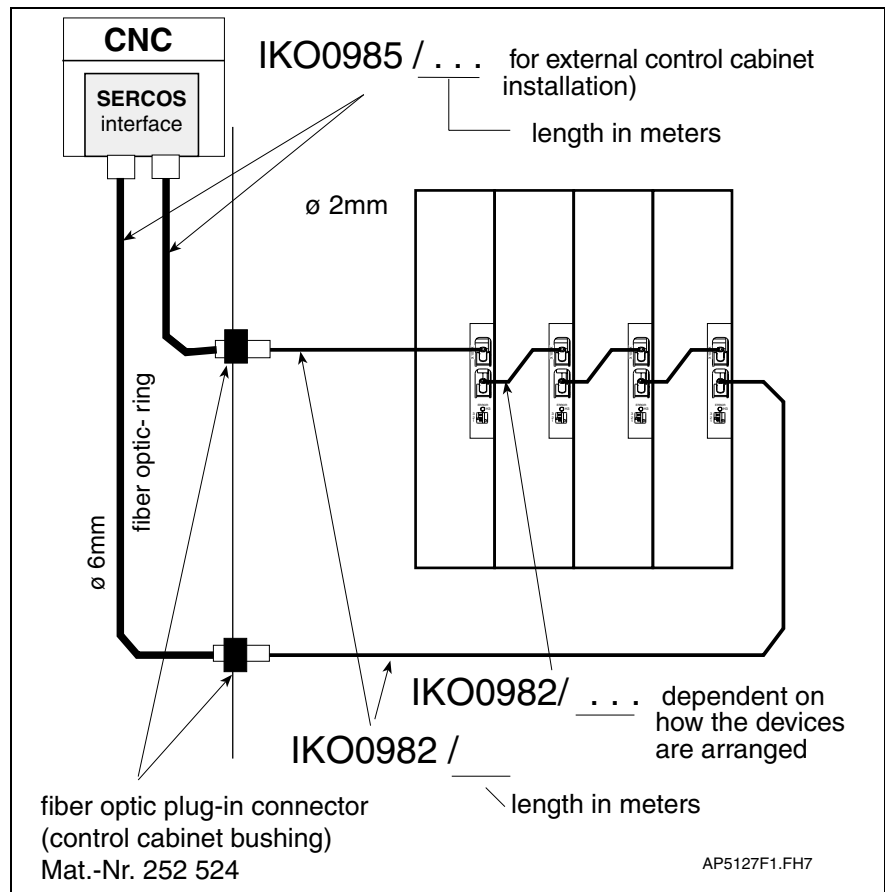

Fig. 4-180: Selecting standard fiber optic cables

DKC 03.3-***-7-FW – Profibus-DP Interface

View of command communication interface

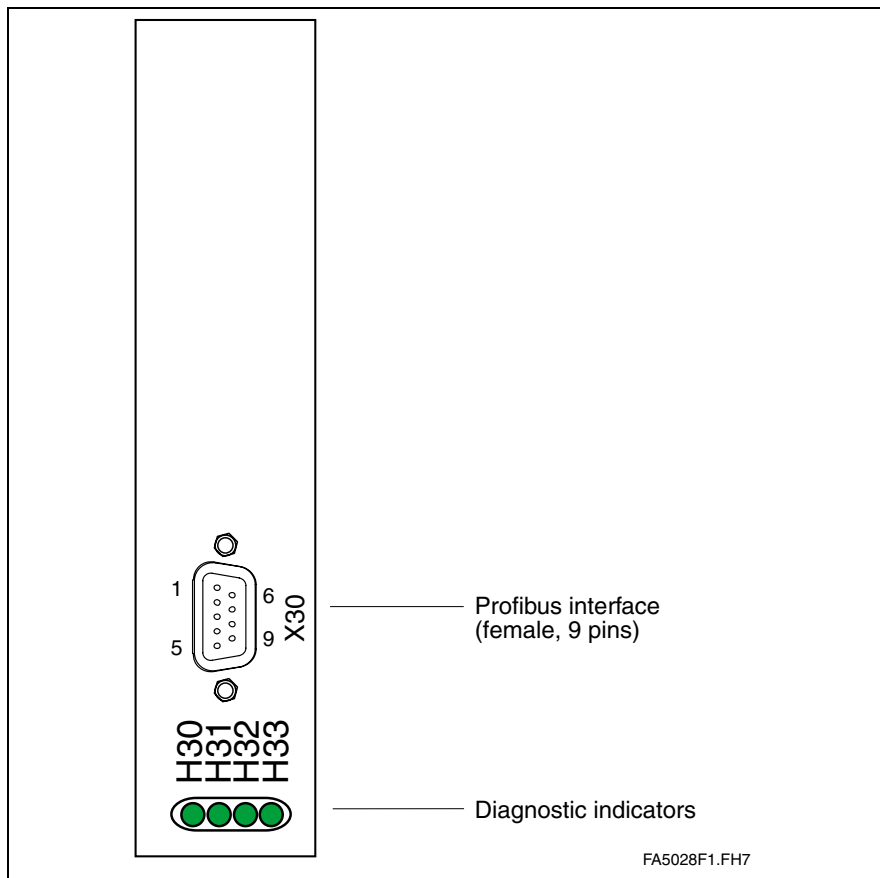

Fig. 4-181: View of command communication interface

Technical description of connector

Design:

Type	No. of pins	Design
D-SUB	9	Bushing on the unit

Fig. 4-182: Design

Connection cross sections:

Cross sections single wire [mm ²]	Cross sections multi core wire [mm ²]	Cross sections in AWG gauge no.:
--	0.08-0.5	--

Fig. 4-183: Connection cross sections

Connection diagram for Profibus-DP Interface

Connection Profibus-DP interface:

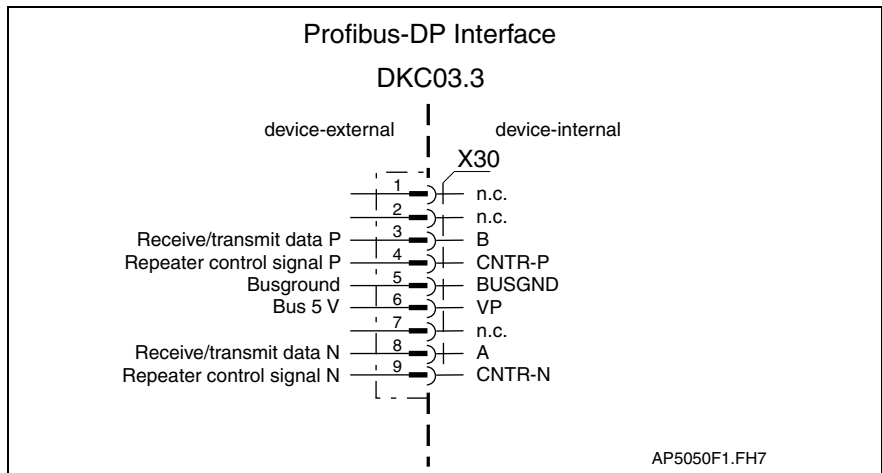

Fig. 4-184: Profibus-DP interface for DKC03.3

Interface compatibility: As per DIN EN 50 170

Recommended cable type: as per DIN EN 50 170 – 2, cable type A

Plug-in connector assignment X30:

Pin	DIR	Signal	Function
1		--	n.c.
2		--	n.c.
3	I/O	RS485+	receive/transmit data plus
4	O	CNTR-P	Repeater control signal
5		0 V	0 V
6	O	+5 V	Repeater supply
7		--	n.c.
8	I/O	RS485-	receive/transmit data minus
9		0 V	0 V

Fig. 4-185: Signal assignment of connector X30

Shield connection: Via D-subminiature screws and metal connector housing.

Signal Specification:

Signal	Specification
+5 V Repeater supply	+5 V ($\pm 10\%$) max. 75 mA
Repeater control signal	TTL compatible 1: transmit 0: receive Output resistance: 350 R $V_{OL} \leq 0.8 \text{ V}$ at $I_{OL} \leq 2 \text{ mA}$ $V_{OH} \geq 3.5 \text{ V}$ at $I_{OH} \leq 1 \text{ mA}$
Receive/send data	EIA-RS485 standard

Fig. 4-186: Signal specification

**CAUTION**
**Danger of destroying output
"+5V Repeater supply" with overload!**

⇒ do not short

⇒ do not exceed maximum current

**Diagnostic display
H30 – H33:**

The definition of the displays are in the firmware.

Bus Connector

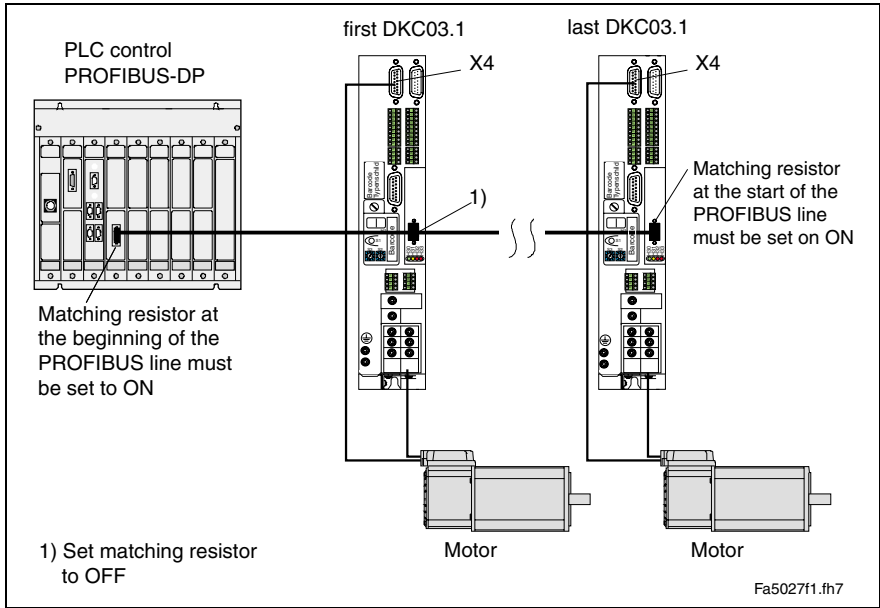

Fig. 4-187: An example of connecting a DKC03.3 to the PLC control via the PROFIBUS-DP

The PROFIBUS connectors each have a connectable terminating resistor. The terminating resistor must always be active at both the first and last bus stations. Do not interchange the A and B wires. Perform the connection as shown in the figures below.

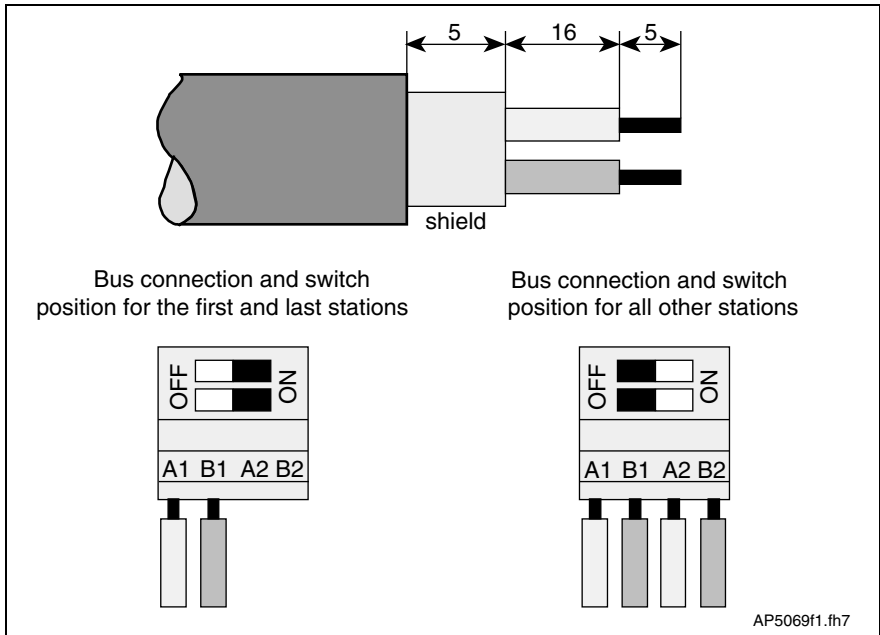

Fig. 4-188: Preparing a cable for connecting a bus connector

To prepare a bus cable, proceed as follows:

- Use cable DIN EN50170 / 2 edition 1996
- Strip cable (see previous illustration)
- Insert both cores into screw terminal block

Note: Do not switch A and B.

- Press cable sheath between both clamps
- Screw both strands into screw terminals

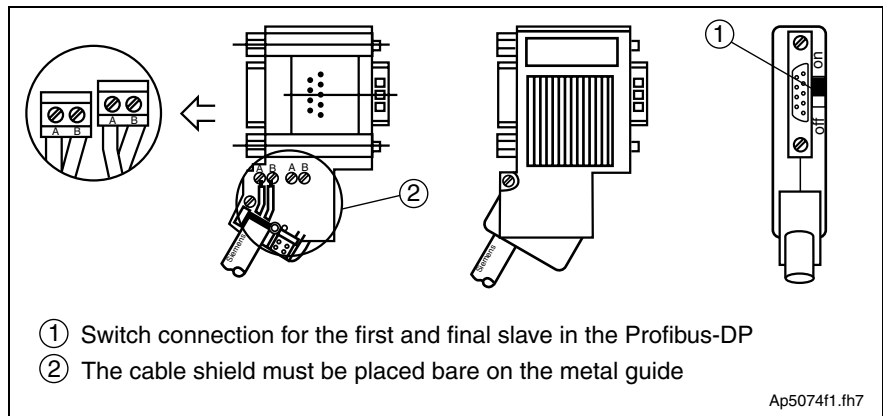

Fig. 4-189: Bus links for the first and last slave, bus connector with 9-pin D-SUB socket, INS 0541

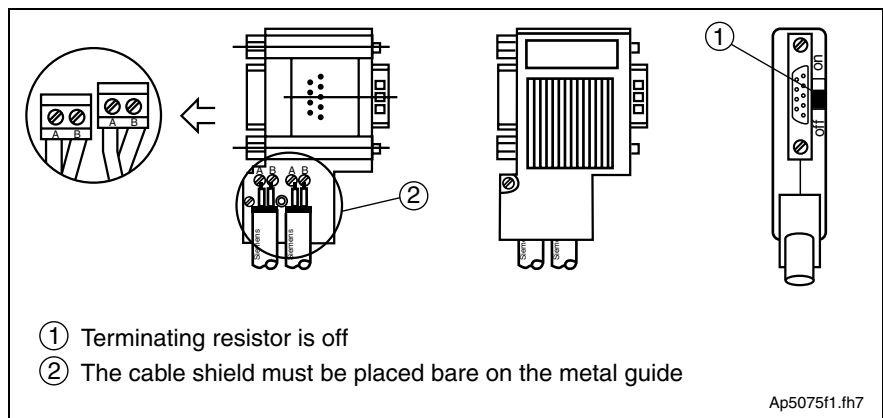

Fig. 4-190: Bus link for all other slaves, bus connector with 9-pin D-SUB socket, INS 0541

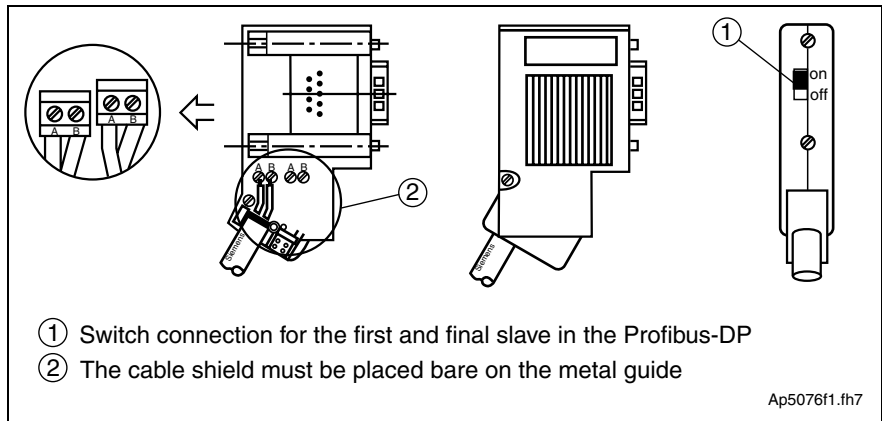

Fig. 4-191: Fig. 4-23: Bus link for the first and last slave without 9-pin D-SUB socket, INS 0540

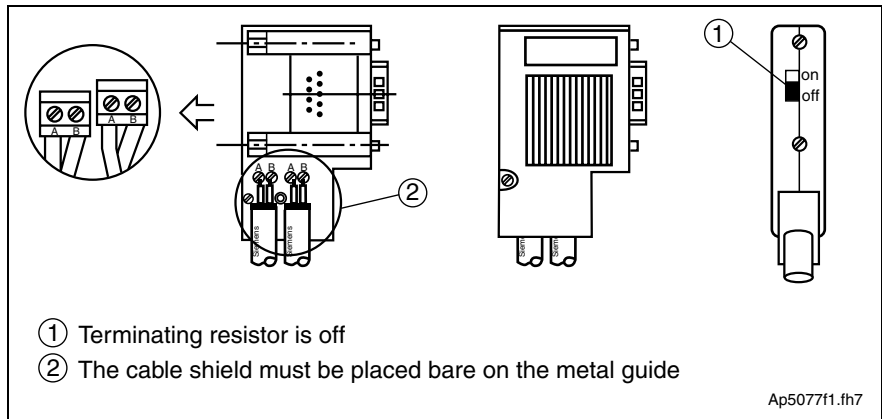

Fig. 4-192: Bus link for all other slaves without 9-pin D-SUB socket, INS 0540

Connect the DKC03.3 to a control unit using a shielded two-wire conductor in accordance with DIN 19245/ section 1.

DKC 04.3-***-7-FW – InterBus Interface

View of command communication interface

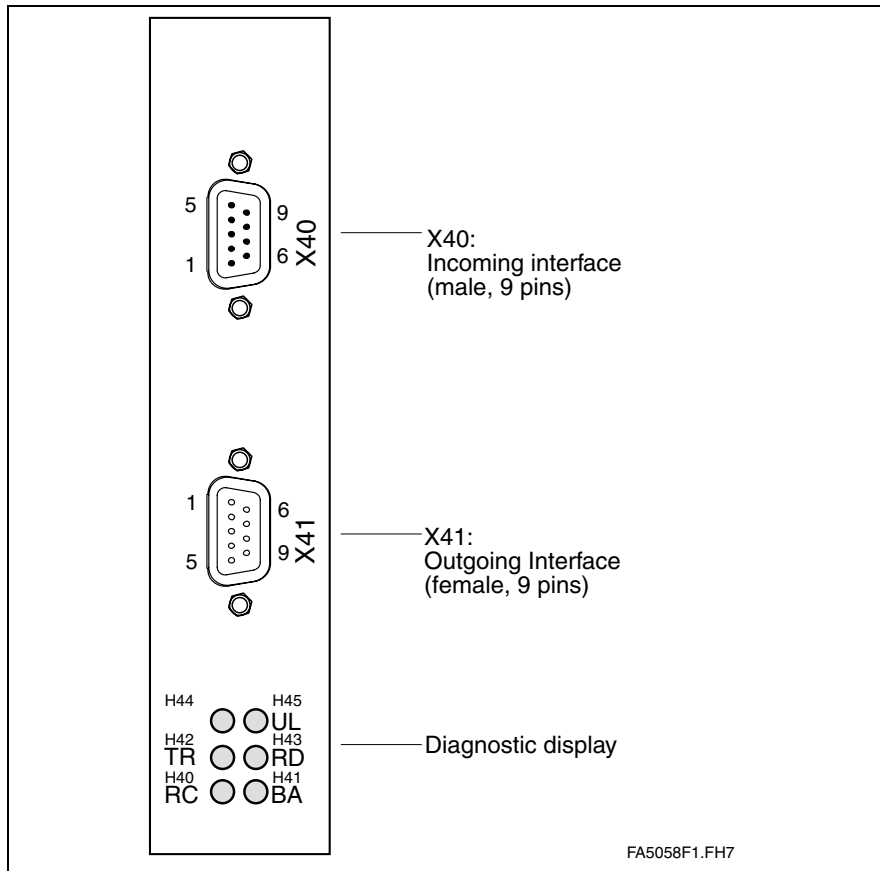

Fig. 4-193: View of command communication interface

Technical description of connector

Design:	Type	No. of pins	Design
X40:	D-SUB	9	bushing on the unit
X41:	D-SUB	9	pins on the unit

Fig. 4-194: Design

Connection cross section:

Cross sections single wire [mm ²]	Cross sections multi core wire [mm ²]	Cross sections in AWG gauge no.:
--	0.08-0.5	--

Fig. 4-195: Connection cross sections

Connection diagram for InterBus Interface

Connection InterBus Interface:

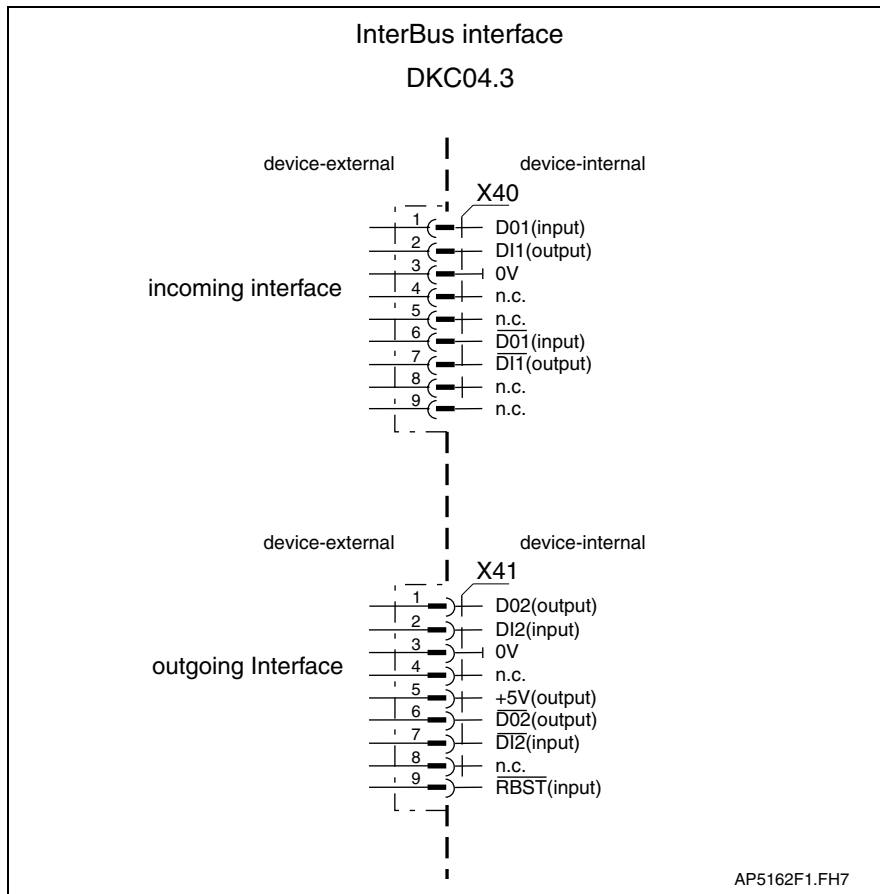

Fig. 4-196: InterBus Interface for DKC04.3

Interface compatibility as per DIN EN 50 254 - 1

Signal specification as per DIN EN 50 254 - 1

Lead length: as per DIN EN 50 254 - 1

Recommended cable: as per DIN EN 50 254 - 2

Plug-in connector assignment X40 Incoming interface:

Pin	DIR	definition
1	I	DO1
2	O	DI1
3	O	0V
4	--	n.c.
5	--	n.c.
6	I	/DO1
7	O	/DI1
8	--	n.c.
9	--	n.c.

Fig. 4-197: Allocation of interface signals X40, Incoming interface

Pin	DIR	definition
1	O	DO2
2	I	DI2
3	O	0V
4	--	n.c.
5	O	+ 5V
6	O	/DO2
7	I	/DI2
8	--	n.c.
9	I	/RBST

Fig. 4-198: Allocation of interface signals X41, outgoing interface

Shield connection: Via D-subminiature mounting screws and metal connector housing.

Signal specification: as per DIN EN 50 254 - 1
Incoming and outgoing interfaces must be isolated from each other and galvanically from the controller.

Diagnostics display H40 – H45: The definition of the displays are in the firmware function description.

DKC 05.3-***-7-FW – CANopen Interface

View of command communication interface

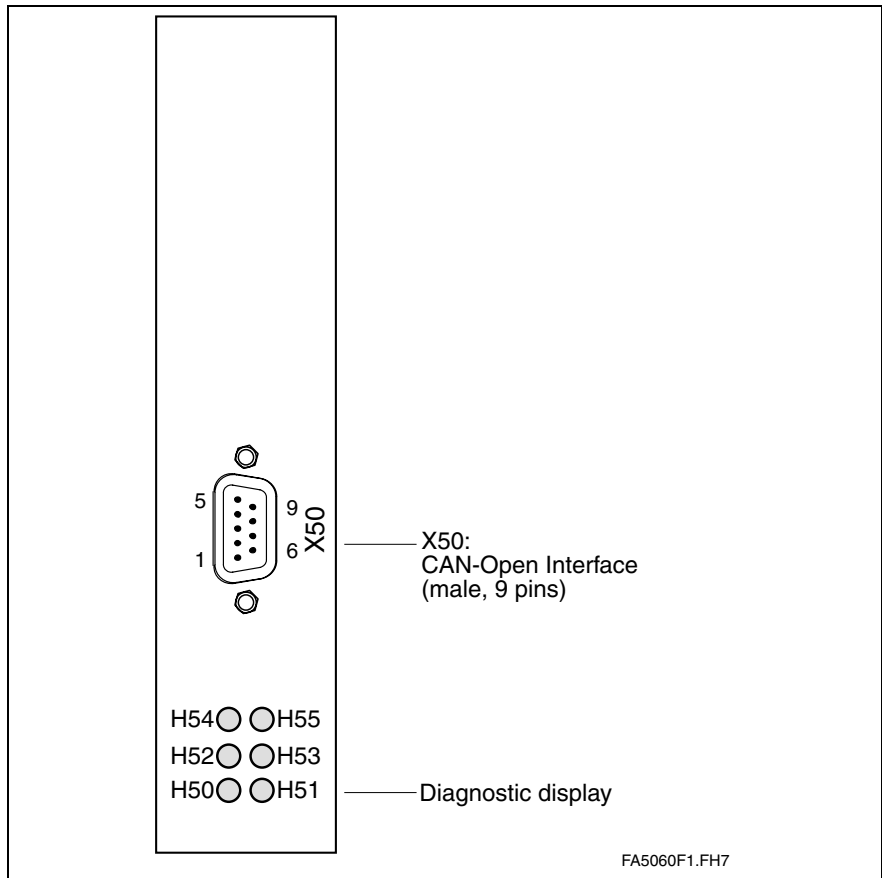

Fig. 4-199: View of command communication interface

Technical description of connector

Design:	Type	No. of pins	Design
	D-SUB	9	pins on the unit

Fig. 4-200: Design

Connection cross sections:

Cross sections single wire [mm ²]	Cross sections multi core wire [mm ²]	Cross sections in AWG gauge no.:
--	0.08-0.5	--

Fig. 4-201: Connection cross sections

Connection diagram for CANopen Interface

**Connection
CANopen interface:**

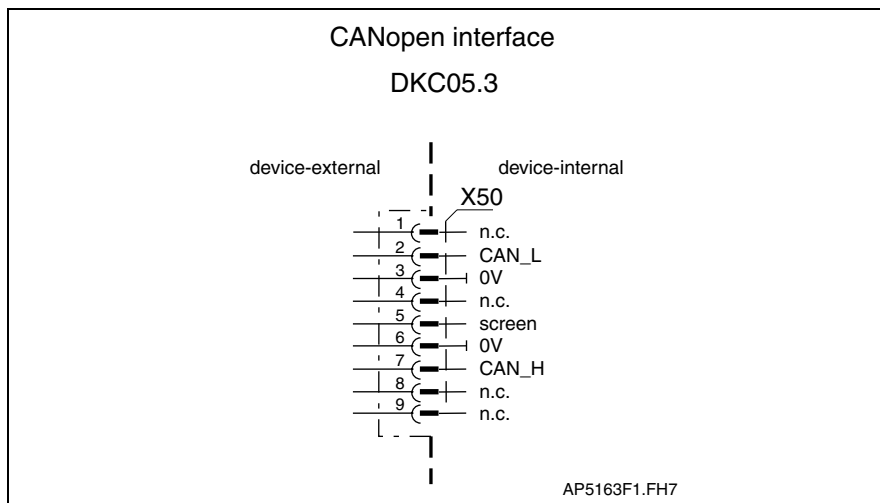

Fig. 4-202: CANopen interface for DKC05.3

Interface compatibility: as per ISO 11 898

Recommended cable: as per ISO 11 898

**Plug-in connector assignment
X50:**

Pin	Definition	
1	n.c.	n.c.
2	CAN_L	Differential signal
3	0V	Gnd
4	n.c.	n.c.
5	shield	Shield connection
6	0V	0V
7	CAN_H	Differential signal
8	n.c.	n.c.
9	n.c.	n.c.

Fig. 4-203: Interface signal allocation

Shield connection: Via D-subminiature mounting screws and metal connector housing.

**Diagnostic display
H50 – H55:** The definition of the diagnostic displays are in the firmware function description.

DKC 06.3-***-7-FW – DeviceNet Interface

View of command communication interface

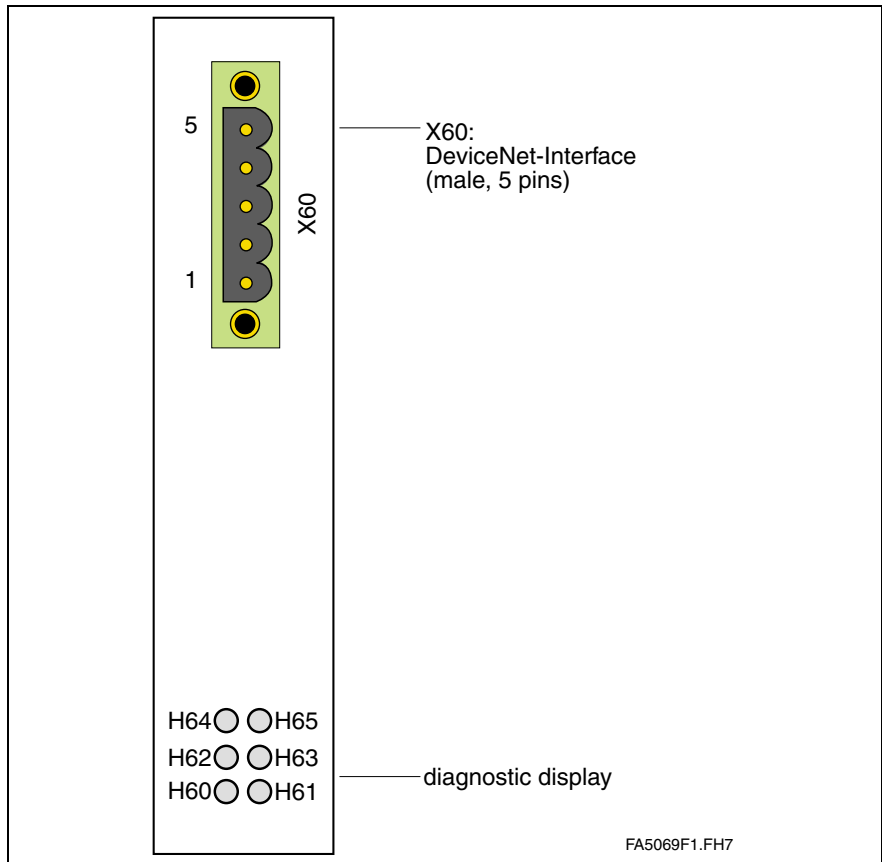

Fig. 4-204: View of command communication interface

Technical description of connector

Design:

Type	No. of pins	Design
COMBICON	5	Bushing on the connector

Fig. 4-205: Design

Connection cross sections:

Cross sections single wire [mm ²]	Cross sections multi core wire [mm ²]	Cross sections in AWG gauge No.:
0.2-2.5	0.2-1.5	24-16

Fig. 4-206: Connection cross sections

Connection diagram for DeviceNet-Interface

Connection DeviceNet Interface:

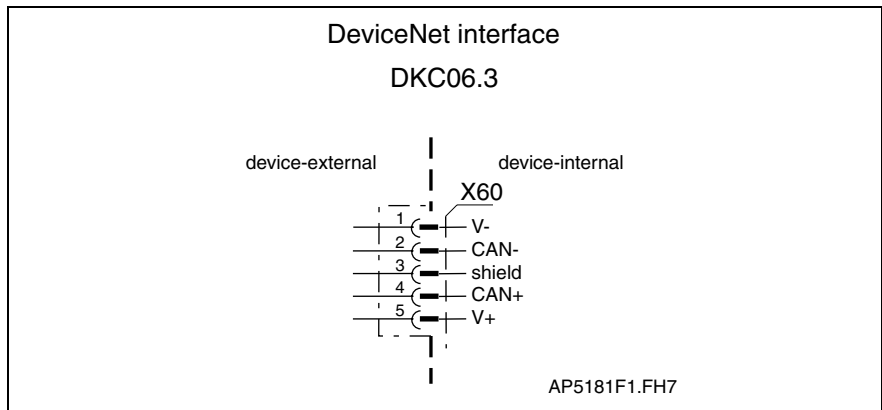

Fig. 4-207: DeviceNet Interface for DKC06.3

Interface compatibility: as per DeviceNet Specification 2.0 Vol. 1
Open Screw Connector

Recommended cable: as per DeviceNet Specification 2.0 Vol. 1, Appendix B

Bus participant connections: as per DeviceNet specification 2.0 Vol. 1, Appendix B
end resistance: 121 Ohm, 1%, ¼ W

Baud rate and cable length: as per DeviceNet specification 2.0 Vol. 1,

Plug-in connector assignment X60:

Pin	Definition	
1	V-	0V
2	CAN-	Differential signal
3	shield	Shield connection
4	CAN+	Differential signal
5	V+	Interface supply

Fig. 4-208: Interface signal allocation

Maximum bus voltage: +30 V

Current feed at bus:

Bus voltage	Current feed
11 V	70 mA
18 V	45 mA
24 V	35 mA
32 V	28 mA

Fig. 4-209: Current feed via bus connector

Diagnostic display H60 – H65: The definition of the diagnostic displays is in the firmware function description.

DKC 11.3-***-7-FW – Analog Interface

See page 4-40" "ECODRIVE03 DKC**.040, DKC**.100, DKC**.200
Electrical connections - independent of the drive controller type".

DKC 21.3-***-7-FW – Parallel Interface 2

View of command communications interface

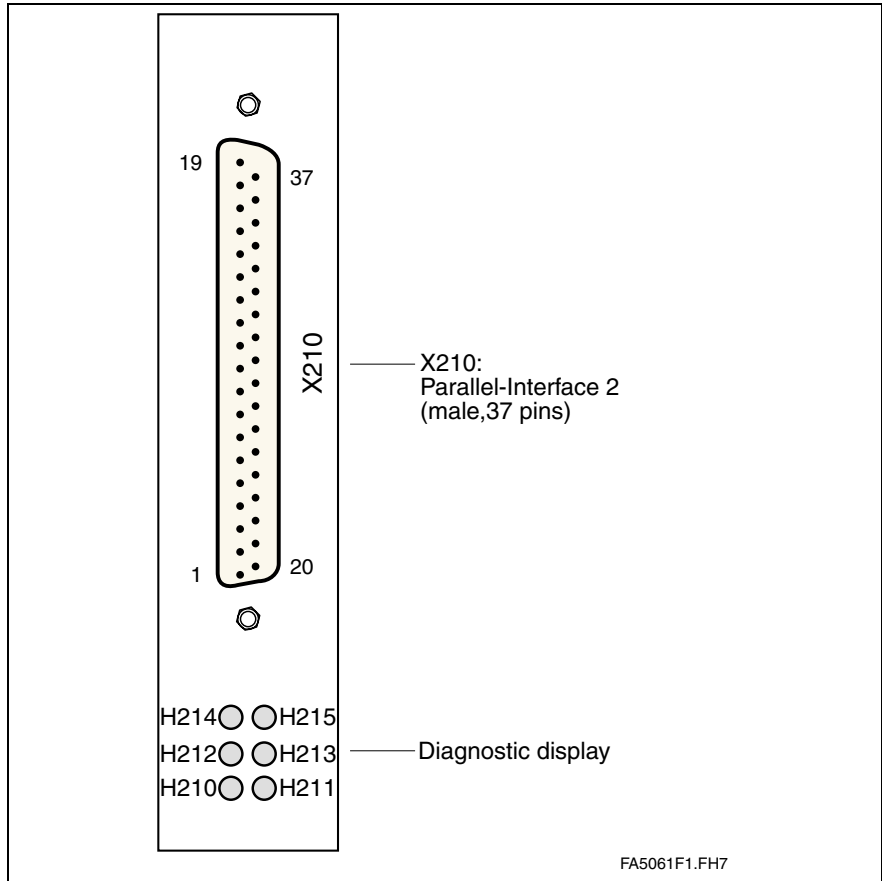

Fig. 4-210: View of command communications interface

Technical description of connector

Design:	Type	No. of pins	Design
	D-SUB	37	pins on the unit

Fig. 4-211: Design

Connection cross section:

Cross sections single wire [mm ²]	Cross sections multi core wire [mm ²]	Cross sections in AWG gauge No.:
--	0.08-0.5	--

Fig. 4-212: Connection cross sections

Connection diagram for parallel interface 2

Connection
Parallel Interface 2:

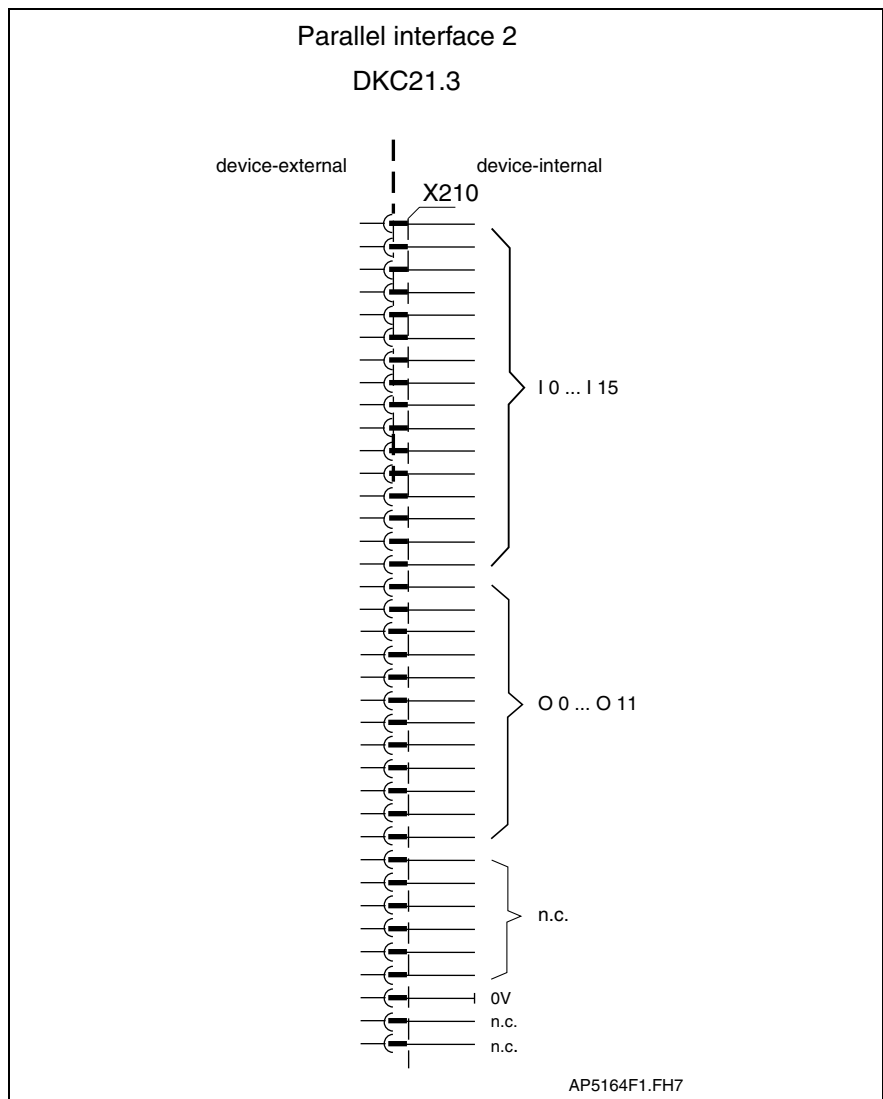

Fig. 4-213: Parallel interface 2 for DKC21.3

Diagnoses display H210 – H215: The definitions of the displays are listed in the firmware functional description.

Plug-in connector assignment
X210:

Pin	IO	Function	Pin	IO	Function
1	I	I 00	20	O	Q 03
2	I	I 01	21	O	Q 04
3	I	I 02	22	O	Q 05
4	I	I 03	23	O	Q 06
5	I	I 04	24	O	Q 07
6	I	I 05	25	O	Q 08
7	I	I 06	26	O	Q 09
8	I	I 07	27	O	Q 10
9	I	I 08	28	O	Q 11
10	I	I 09	29		n.c.
11	I	I 10	30		n.c.
12	I	I 11	31		n.c.
13	I	I 12	32		n.c.
14	I	I 13	33		n.c.
15	I	I 14	34		n.c.
16	I	I 15	35		0V
17	O	Q 00	36		n.c.
18	O	Q 01	37		n.c.
19	O	Q 02	--	--	--

Fig. 4-214: Signal assignment of 37-pin connector X210

Shield connection: Via D-subminiature mounting screws and metal connector housing.

Input circuit
I 1 – I 15:

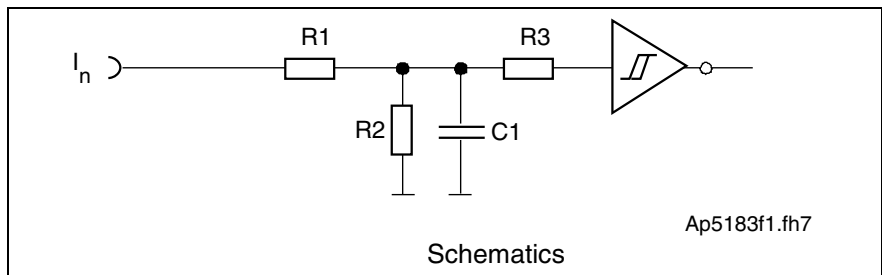

- R1: 10k
- R2: 3k3
- R3: 10k
- C1: no data

Fig. 4-215: input circuit

Signal range of inputs
I 1 – I 15:

Input voltage:	min.	max.
High	16 V	30 V
Low	-0.5 V	3 V
Input resistance	13.3 kOhm ±5%	
reaction time	=> see firmware functional description	

Fig. 4-216: Inputs

Output circuit connection Q 0 – Q 11:

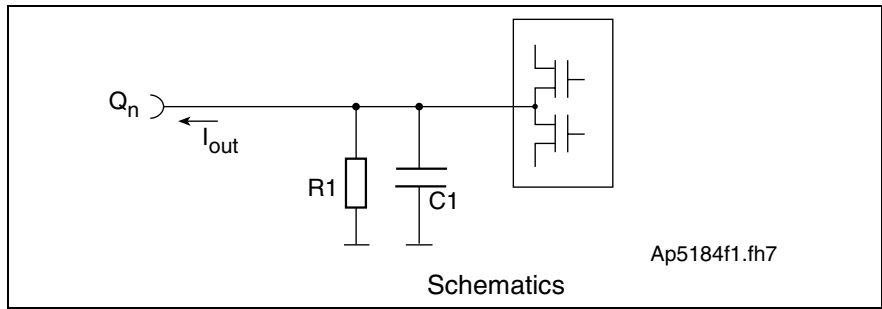

R1: 20k
C1: no data

Fig. 4-217: Output circuit

Output connection Q 0 – Q 11:

Output voltage:	min.	max.
High	16 V	U_{ext}
Low	-0.5 V	1.5 V
Output current I_{out}	80 mA	
rise and drop time	about < 600 ns	
overload protection	- short circuit protection; at $I_{out} > 300$ mA outputs switch off - thermal off	

Fig. 4-218: Outputs

Default allocation of binary I/Os:

Pin	Inputs		Pin	Outputs	
1	I 0	Parameter	17	Q 0	Hand
2	I 1	Hand / Auto	18	Q 1	Auto
3	I 2	Start	19	Q 2	$\overline{\text{Error}}$
4	I 3	$\overline{\text{STOP}}$	20	Q 3	Run
5	I 4	Jog+	21	Q 4	Output 01
6	I 5	Jog-	22	Q 5	Output 02
7	I 6	Input 01	23	Q 6	Output 03
8	I 7	Input 02	24	Q 7	Output 04
9	I 7	Input 03	25	Q 8	Output 05
10	I 9	Input 04	26	Q 9	Output 06
11	I 10	Input 05	27	Q 10	Output 07
12	I 11	Input 06	28	Q 11	Output 08
13	I 12	Input 07			
14	I 13	Input 08			
15	I 14	Input 09			
16	I 15	Input 10			

Fig. 4-219: Default allocation of the inputs and outputs

Note: Inputs 01 ... 10 and Output 01 ... 08 can be configured.

DKC 22.3-***-7-FW – SERCOS interface

View of command communications interface

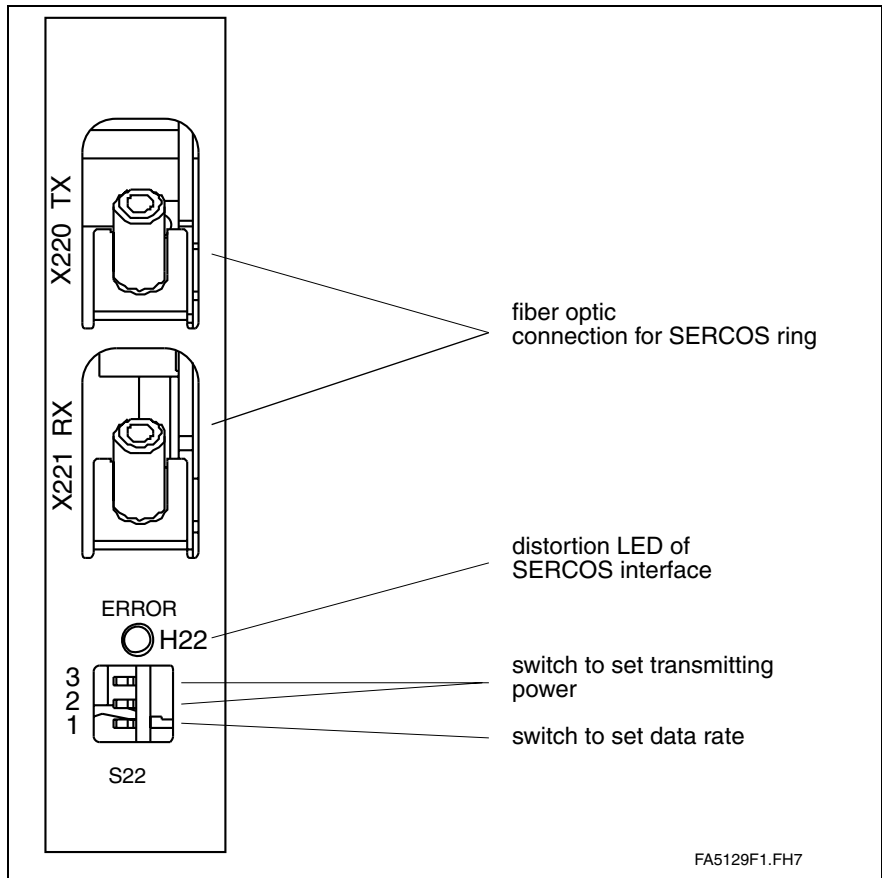

Fig. 4-220: View of command communication interface

Connection diagram for SERCOS interface 2

Connection SERCOS Interface 2:

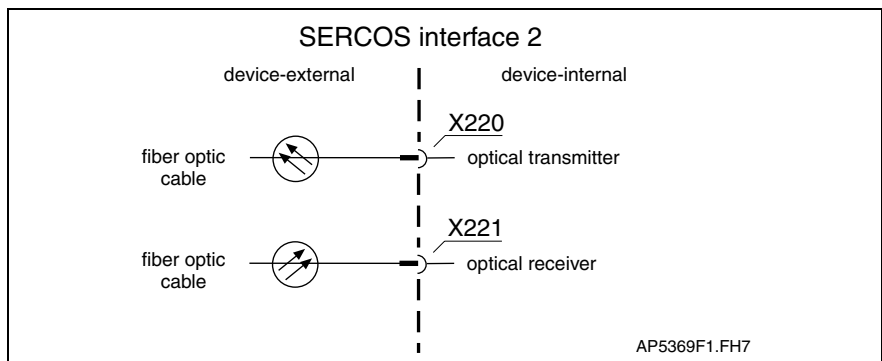

Fig. 4-221: I/O connection allocations

Switch S22

See page 4-105: "Switch S20".

Fiber optic cables

See page 4-106: "Fiber optic cables".

Notes

5 ECODRIVE03 DKC**.3-016

5.1 Technical Data

Dimensions

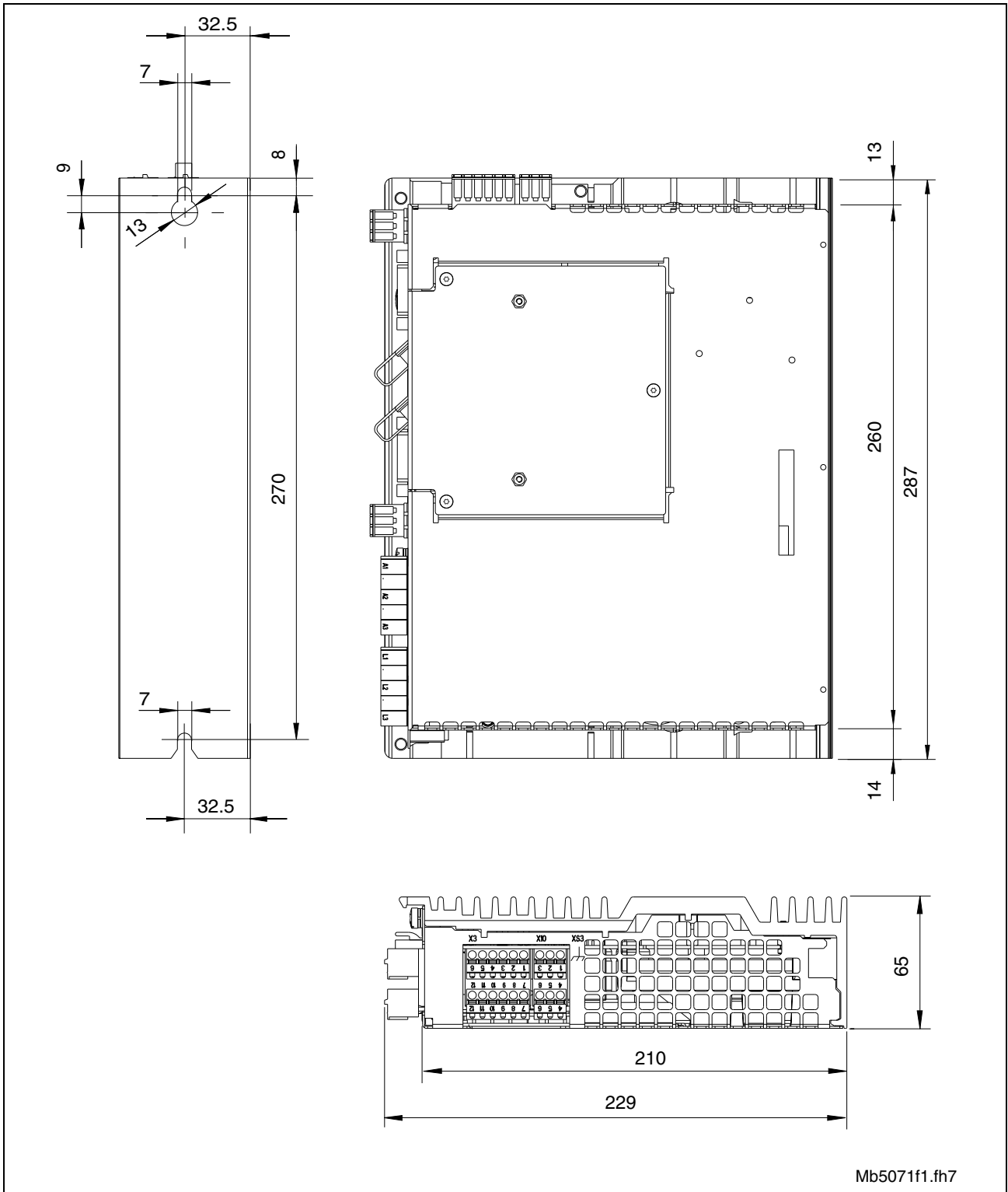

Fig. 5-1: Drive Controller DKC**.3-016-7-FW

Materials used, Mass

Designation	Symbol	Unit	DKC**.3-016-7-FW
Mass	m	kg	3,2
Materials used	free of asbestos and silicone		

Fig. 5-2: Materials used; mass

Ambient and operating conditions

See page 4-4.

Electric Data of the Individual DKC**.3-016 Components

Mains connections, Power section DKC**.3-016-FW

Designation	Symbol	Unit	DKC**.3-016-7-FW	
			single phase	three phase
Operating mode at the mains			single phase	three phase
Mains input voltage	U_{N1}	V	1 x AC (200 ... 480) \pm 10%	3 x AC
Mains frequency	f_{N1}	Hz	(50 ... 60) \pm 2	
Rotary field			clockwise or counter-clockwise	
Connected load	S_{N1}	kVA	see page 11-1: "Mains Connections"	
Nominal charging current (dependent on mains input voltage)			1.2 ... 2.8	
Soft-start resistor	$R_{Softstart}$	Ohm	240	
Continuous power soft-start resistor	$P_{Softstart}$	kW	0.05 ²⁾	
Switching frequency (selectable)	f_S	kHz	4 or 8	
Type current = peak current 1	I_{PEAK1}	A	16 ¹⁾	
Peak current 2 for $f_S = 4$ kHz	$I_{PEAK2(4kHz)}$	A	6 ¹⁾	
Peak current 2 for $f_S = 8$ kHz	$I_{PEAK2(8kHz)}$	A	5 ¹⁾	
Continuous current 1 for $f_S = 4$ kHz	$I_{CONT1(4kHz)}$	A	4 ¹⁾	
Continuous current 2 for $f_S = 4$ kHz	$I_{CONT2(4kHz)}$	A	6 ¹⁾	
Continuous current 1 for $f_S = 8$ kHz	$I_{CONT1(8kHz)}$	A	2.8 ¹⁾	
Continuous current 2 for $f_S = 8$ kHz	$I_{CONT2(8kHz)}$	A	5 ¹⁾	
Max. output frequency at $f_S=4$ kHz	f_{out}	Hz	400	
Max. output frequency at $f_S=8$ kHz	f_{out}	Hz	800	
Device power dissipation without internal continuous bleeder power for I_{CONT2}	P_V	W	80 (see page 12-1: "Power dissipation")	
Peak bleeder power DKC when $U_{ZW} = 850$ V for permissible load cycle	P_{BS}	kW	2.7 0.29 s on, 20 s off	
Continuous bleeder power DKC when $T_a \leq 45$ °C under max. temperature range with distance	P_{BD} ΔT d	kW K mm	0.05 40 K 80 (see page 12-7)	
Max. energy dissipation	$W_{R,MAX}$	kWs	1.0	
Max. DC bus charge	W_{MAX}	kWs	1.0	
Internal DC bus dynamic brake (ZKS)			not present	
Resistor for ZKS	R_{ZKS}	Ohm	not present	
Storable energy of the DC bus capacitors	W_{ZW}	Ws	see diagrams page 5-9: "Storable energy in the bus"	
Nominal DC bus capacitance DKC	C_{ZW}	mF	0.135 \pm 20%	
DC bus voltage (dependent on mains input voltage)	U_{ZW}	V	DC 300 ... 800	
DC bus continuous power (dependent on mains input voltage)	P_{ZWD}		see diagrams page 5-12 "Allowed DC bus continuous power"	
max. DC bus continuous power for a single source supply where $U_{N1} = 3 \times AC 400$ V, when $T_a \leq 45$ °C	P_{ZWD}	kW	0.5	

Designation	Symbol	Unit	DKC**.3-016-7-FW
max. DC bus continuous power for a single source supply where $U_{N1} = 3 \times \text{AC } 480 \text{ V}$, when $T_a \leq 45 \text{ }^\circ\text{C}$	P_{ZWD}	kW	0.6
DC bus peak power	P_{ZWS}		see diagrams "Allowed DC bus Peak Power " on page 5-12
Power section cooling			natural convection
Cooling the bleeder resistor			natural convection
Cooling air flow			no forced cooling
Volumetric capacity of the forced cooling		m ³ /h	no forced cooling
Insulation resistance at DC500V	R_{is}	MOhm	> 1
Coupling capacitance power section against housing	C_{Kop}	nF	100 nF

¹⁾ Sine threshold value

²⁾ Softstart resistor is used after softstart as bleeder (R_B).

Fig. 5-3: Technical Data DKC**.3-016-7 Mains connection and Power section

Block diagram of the DKC.3-016-7-FW power section**

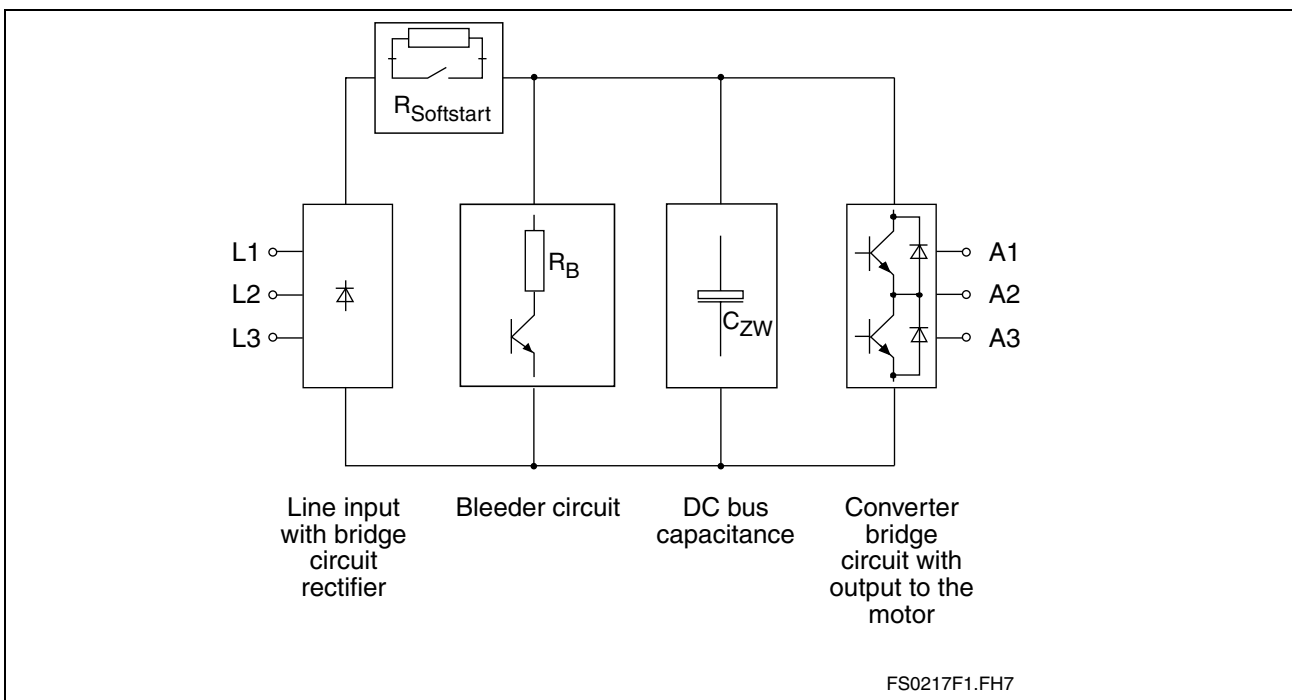

Fig. 5-4: Block diagram of the DKC**.3-016-7-FW power section

Control voltage connection

(Data applies to ambient temperature of 25 °C)

Designation	Symbol	Unit	DKC**.3-016-7-FW	
Control voltage	U_{N3}	V	DC (19.2 ... 28.8) V	
max. ripple effect	w		may not exceed input voltage range	
max. allowed overvoltage	U_{N3max}	V	45 V for 1 ms, non repetitive *)	
max. charging current	I_{EIN3}	A	2 (see diagram on page 5-7 "Charging current profile of control voltage")	
max. pulse duration of I_{EIN3}	t_{N3Lade}	ms	60 (see diagram on page 5-7 "Charging current profile of control voltage")	
max. input capacitance	C_{N3}	mF	3.0 x 1.2	
Power consumption (X1)	dependent on type of unit, without external load at control outputs and encoder interface 2			
	DKC01.3	P_{N3}	W	15
	DKC02.3	P_{N3}	W	15
	DKC03.3	P_{N3}	W	16
	DKC04.3	P_{N3}	W	17
	DKC05.3	P_{N3}	W	16
	DKC06.3	P_{N3}	W	16
	DKC21.3	P_{N3}	W	16
	DKC22.3	P_{N3}	W	16

Fig. 5-5: Control voltage connection for DKC**.3-016-7-FW

*) To be obtained by appropriate mains sections and shielded wire routing.

Connections for control voltage: see page 5-19 "X1, Connections for control voltage".

-
- Note:** Overvoltages of more than 45 V have to be derived by measures in the electrical equipment of the machine or installation. This includes:
- 24-Volt mains sections that reduce incoming overvoltages to the allowed value.
 - Overvoltage limiters at the control cabinet input that limit existing overvoltages to the allowed value. This also applies to long 24-Volt lines that have been laid in parallel with power and mains cables and can absorb overvoltages caused by inductive or capacitive coupling.
-

Amplitude of the DKC control voltage charging current at startup, to selecting power source

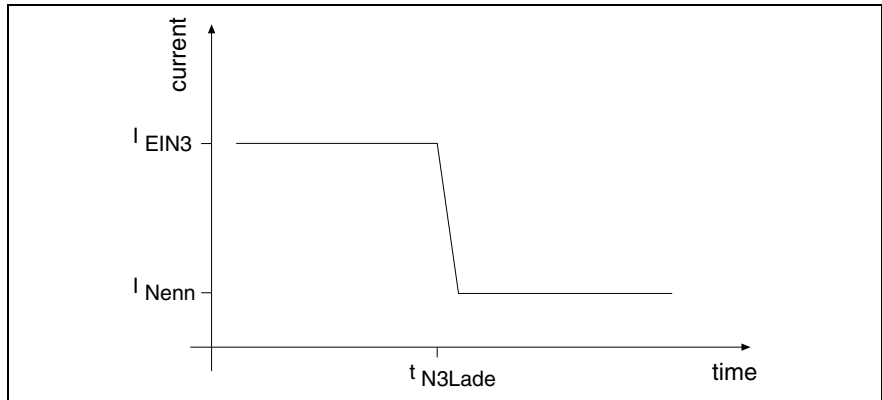

Fig. 5-6: Charging current profile of control voltage

Note: For n parallel-switched inputs the charging current inrush is n-fold.

Voltage connection for holding brake

Designation	Symbol	Unit	DKC**.3-016-7-FW
Input voltage	U_{HB}	V	depending on motor type, see motor project planning manual (see also page 5-36 onward)
Ripple content	w	%	
Current consumption	I_{HB}	A	

Fig. 5-7: Voltage connection for holding brake

Output current characteristic curves for servo applications (acceleration times ≤ 400 ms)

Static profile illustrated:

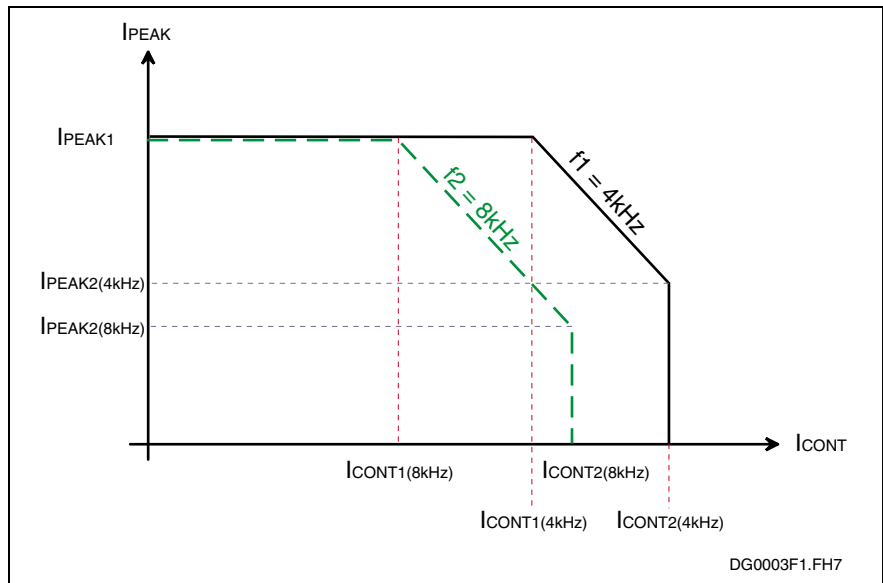

Fig. 5-8: Output current characteristic curves for servo applications

See also table with electrical data on page 5-4.

Storable energy in the bus

Note: The higher the connection voltage the lower the energy that can be stored in the DC bus as the differential voltage between bleeder threshold and DC bus voltage (threshold value of connecting voltage) decreases.

DKC**.3-016-7-FW

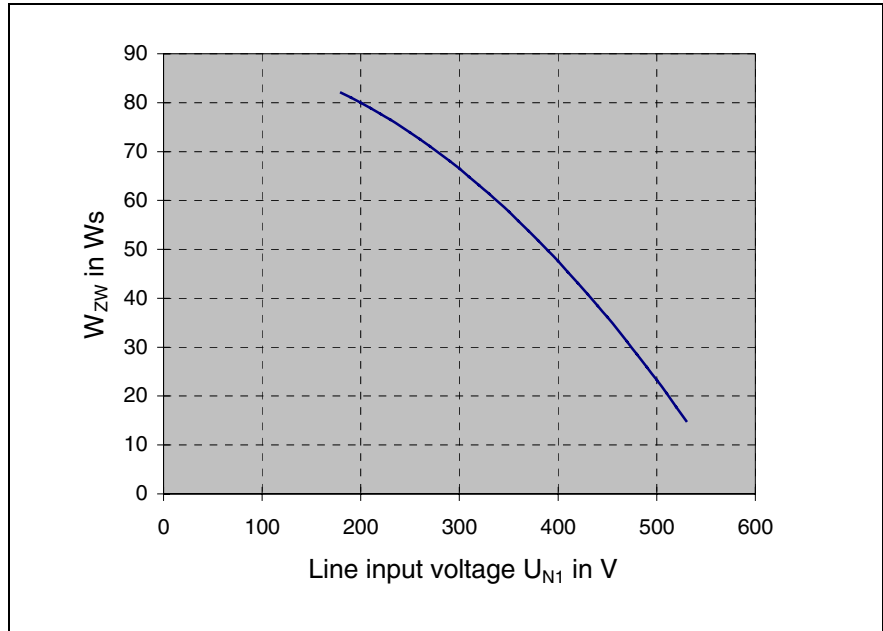

Fig. 5-9: Storable energy in the bus DKC**.3-016-7-FW

Mains supply options

Single source supply

Characteristic for the single source supply is that the mains voltage is applied to the DKC drive controller via individual mains connections.

Arranging the single source supply

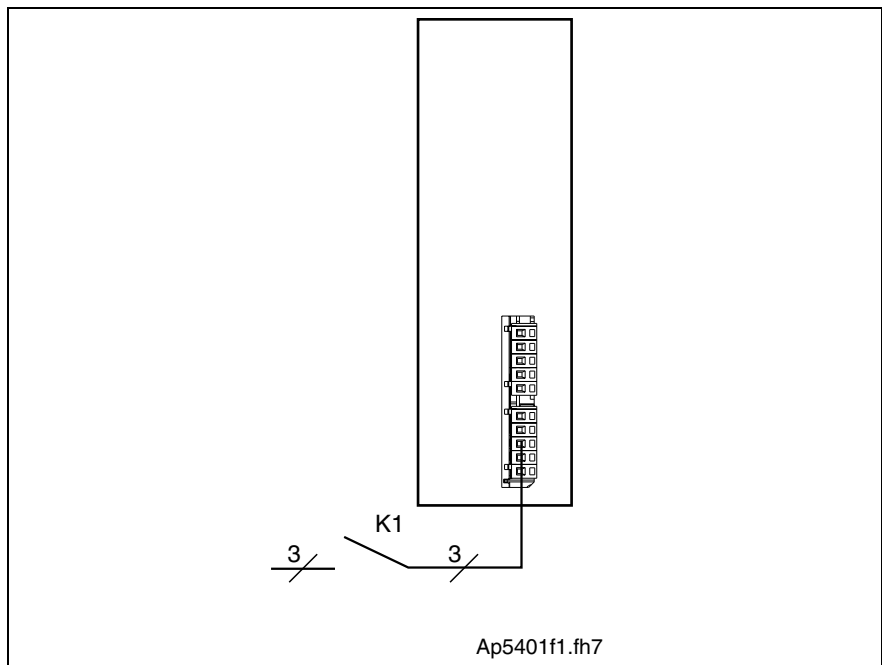

Fig. 5-10: Single source supply

Note: In addition to the illustrated connections of the drive controller at the DC bus, the following connections must be wired as well:

- Bb contact
- control voltage supply

Group supply

"Group supply" is the standard supply if several DKC drive controllers are to be supplied from one supply voltage.

Characteristic for the "group supply" is that the mains voltage is applied to groups of DKC drive controllers via a common mains contactor.

Arranging the single source supply

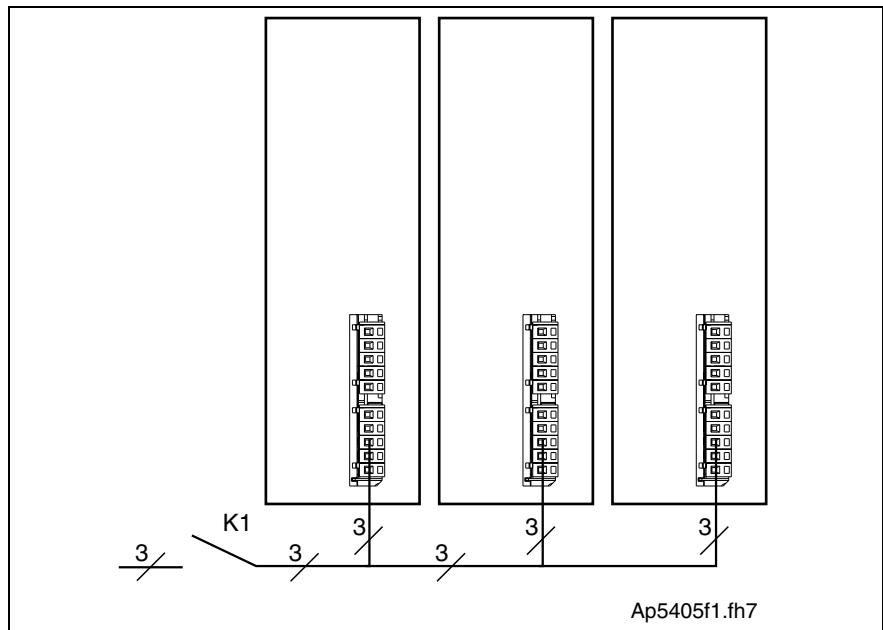

Fig. 5-11: Group supply

Note: In addition to the illustrated connections of the drive controller at the DC bus, the following connections must be wired as well:

- Bb contact
- control voltage supply

Allowed DC bus Peak Power

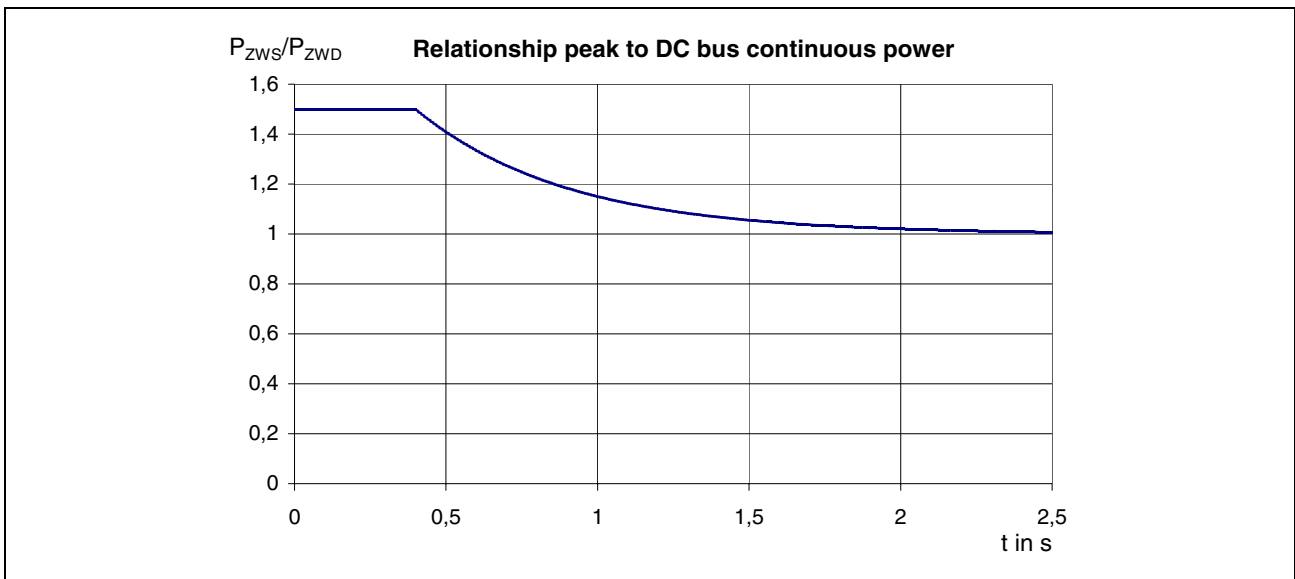

Fig. 5-12: Allowed peak power in DC bus of DKC**.3-016-7-FW

DKC**.3-016-7-FWs are not suited for drive applications if the required intermittent operating power of the unit's nominal power exceeds 50%!

Allowed DC bus continuous power

DKC**.3-016-7 in "Single source supply"

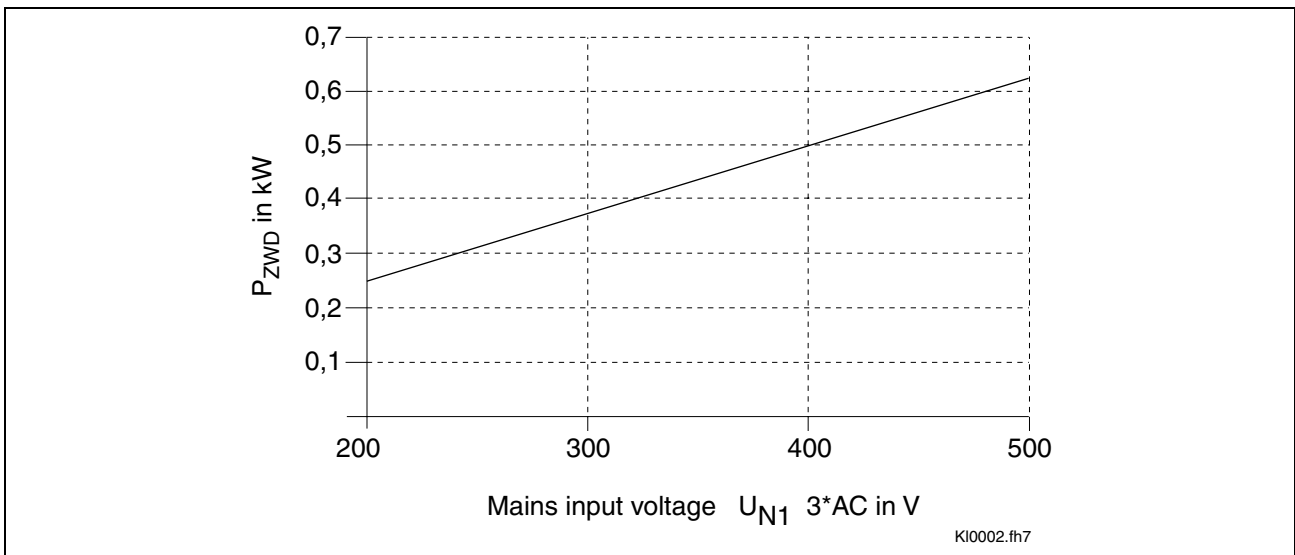

Fig. 5-13: Allowed DC bus continuous power for Single source supply DKC**.3-016-7

Note: Definition of terms, see page 5-10: "Mains supply options".

Allowed DC bus continuous power with single-phase mains connection

The operation of a single-phase mains supply reduces the allowed DC bus continuous power as per the following diagram.

Note: The single-phase mains connection is only permitted with single source supply!
 With single-phase operation peak power in the DC bus is the same as continuous power.

Allowed DC bus continuous power in single-phase mode at supply networks with a frequency of 50 Hz

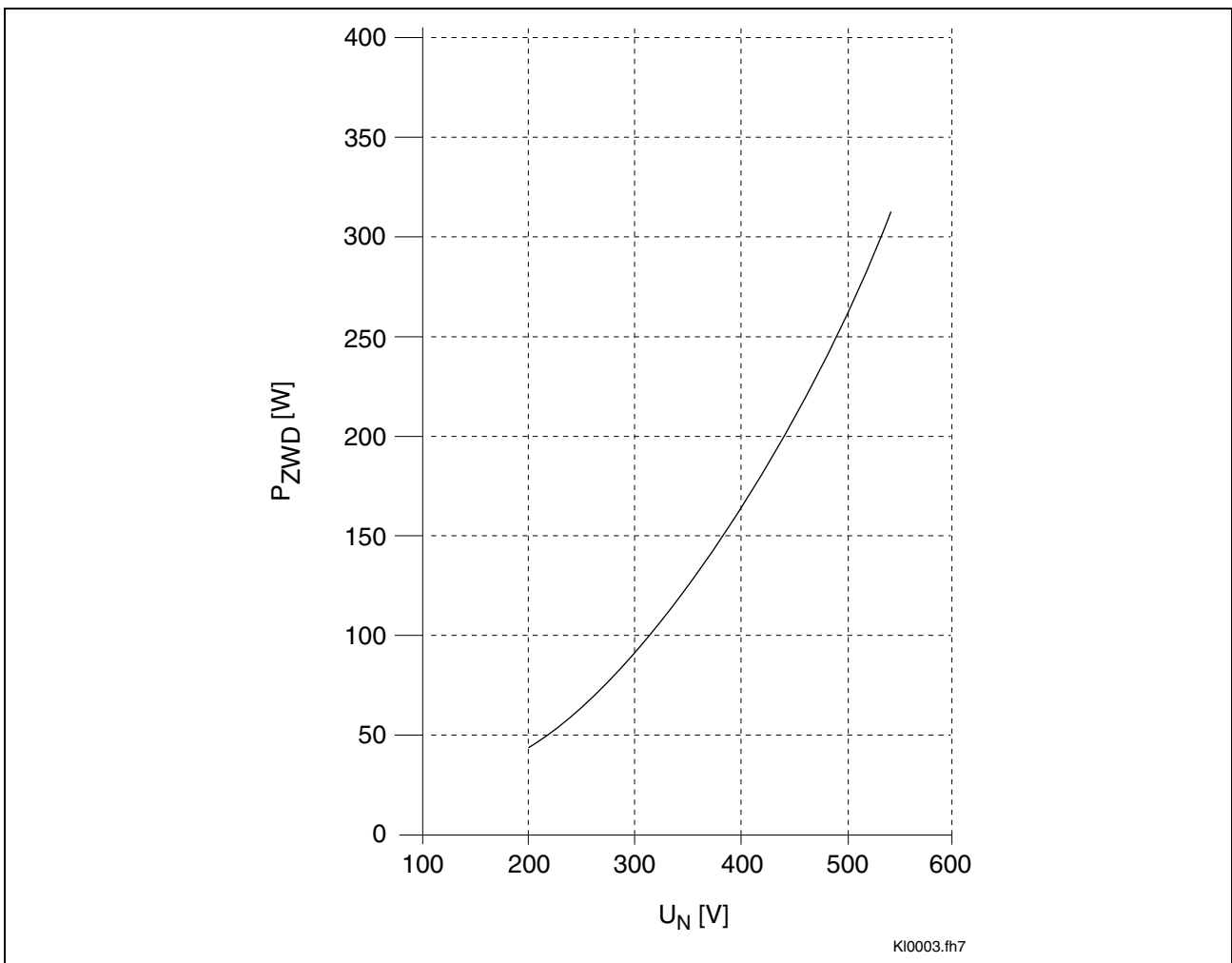

Fig. 5-14: Allowed DC bus continuous power in single-phase mode with 50 Hz

**Allowed DC bus continuous power in single-phase mode
at supply networks with a frequency of 60 Hz**

Fig. 5-15: Allowed DC bus continuous power in single-phase mode with 60 Hz

CE label, C-UL listing, Tests

CE label:

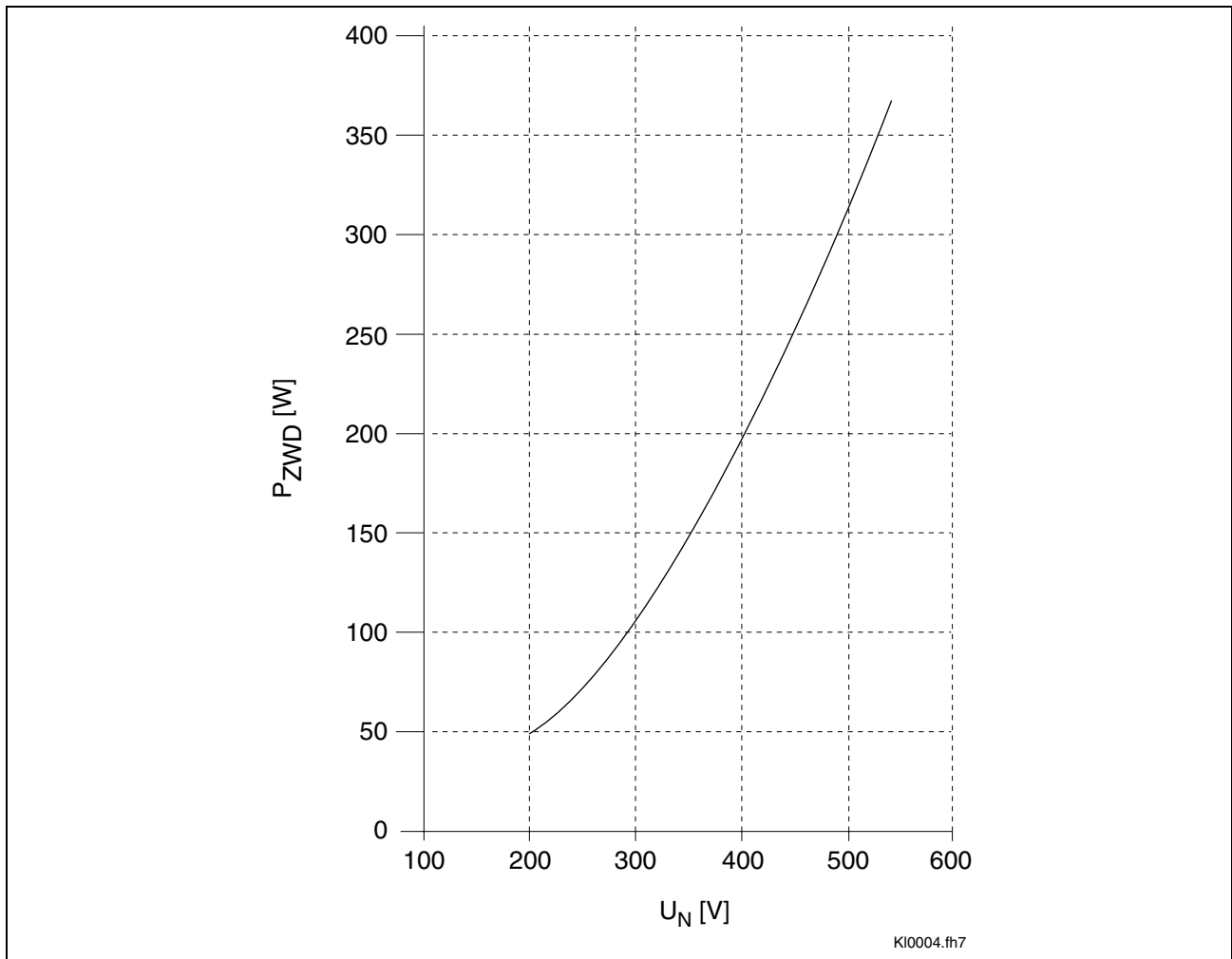
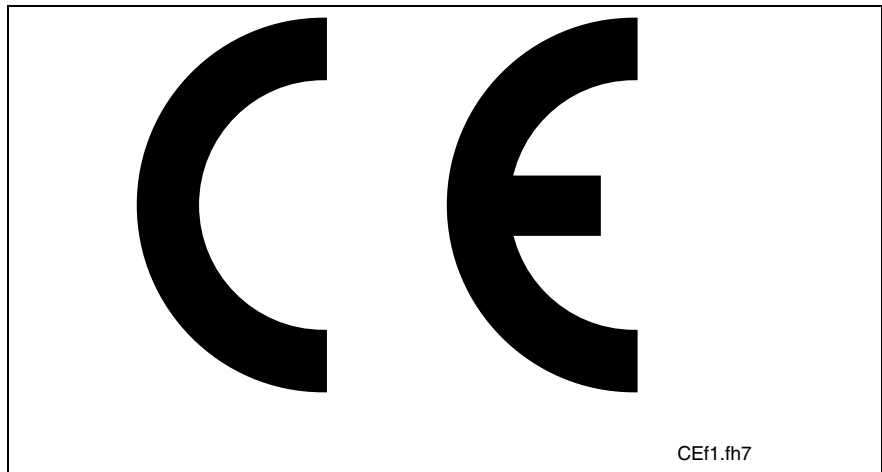

Fig. 5-16: CE label

C-UL listing: • Per UL508 C under file no. E134201

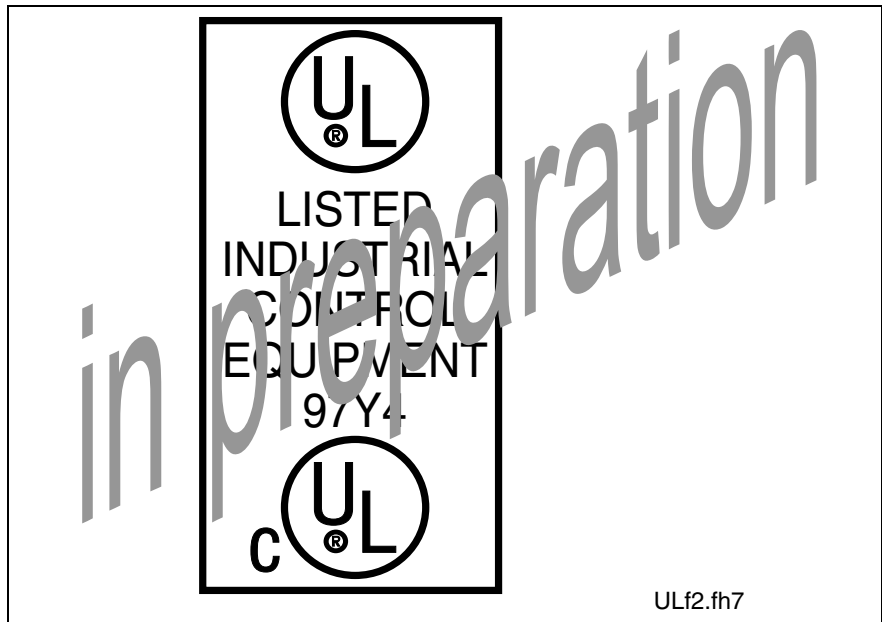

Fig. 5-17: C-UL listing

Tests:

High-voltage test according to EN50178	Routine test with DC2100V	1 s
Insulation test according to EN50178	Routine test with DC500	1 s
Separation between the electrical circuits of the control and high voltage power	safe separation according to EN50178	
Clearances and creepage distances	according to EN50178	

Fig. 5-18: Tests

5.2 Electrical connections

A look at the drive controller and connector designations

Front view

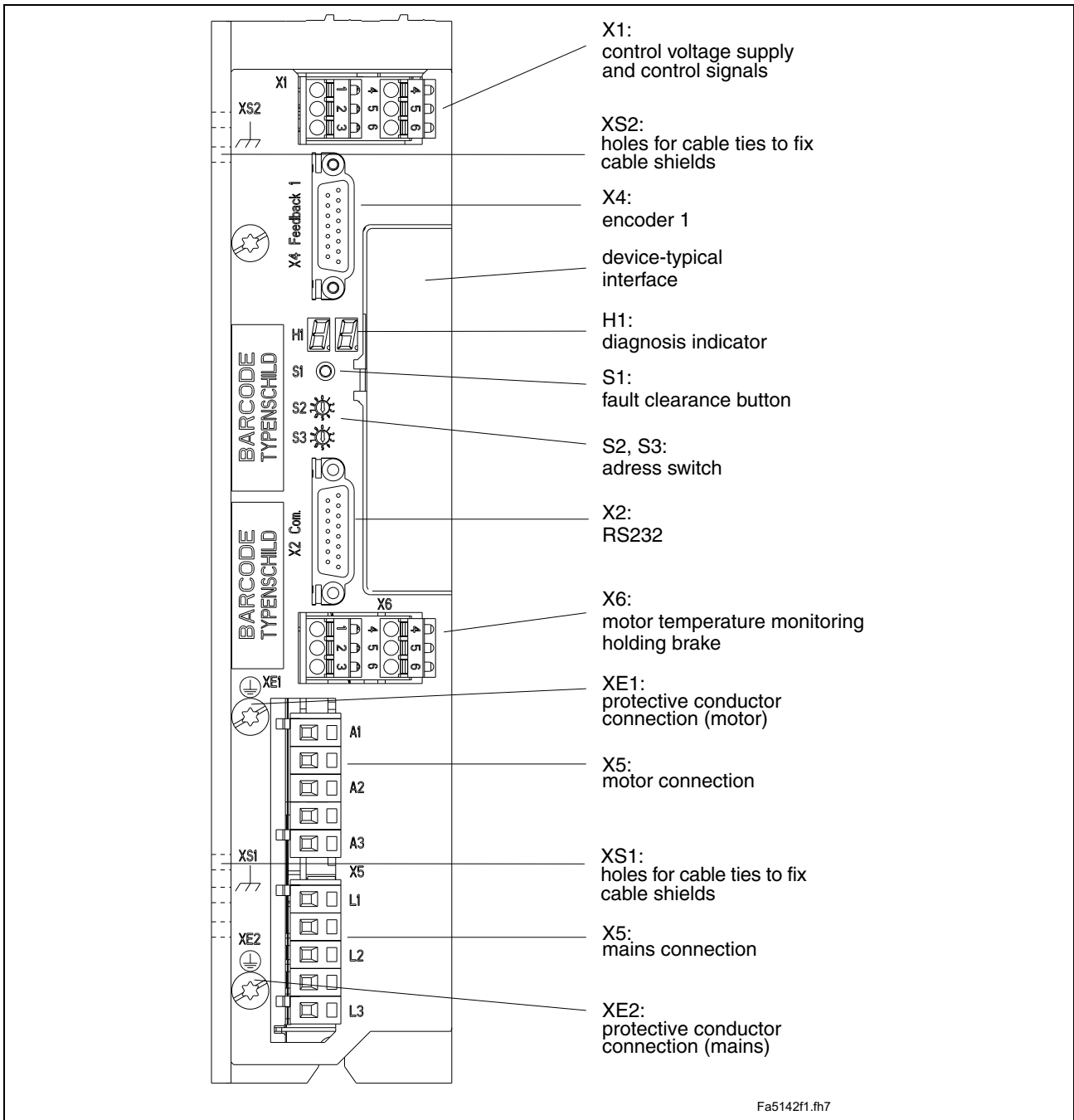

Fig. 5-19: Front view DKC**.3-016 with connectors

Connections on top of the drive controller

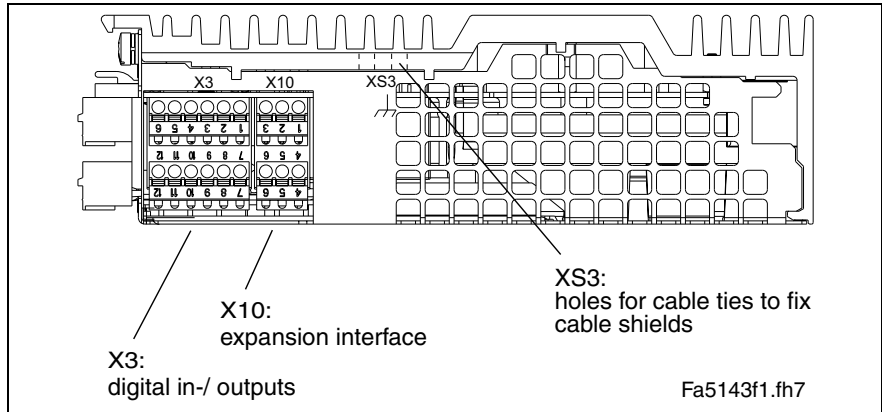

Fig. 5-20: Connections on top of unit for DKC**.3-016-7-FW

Independent of the drive controller type – total connecting diagram

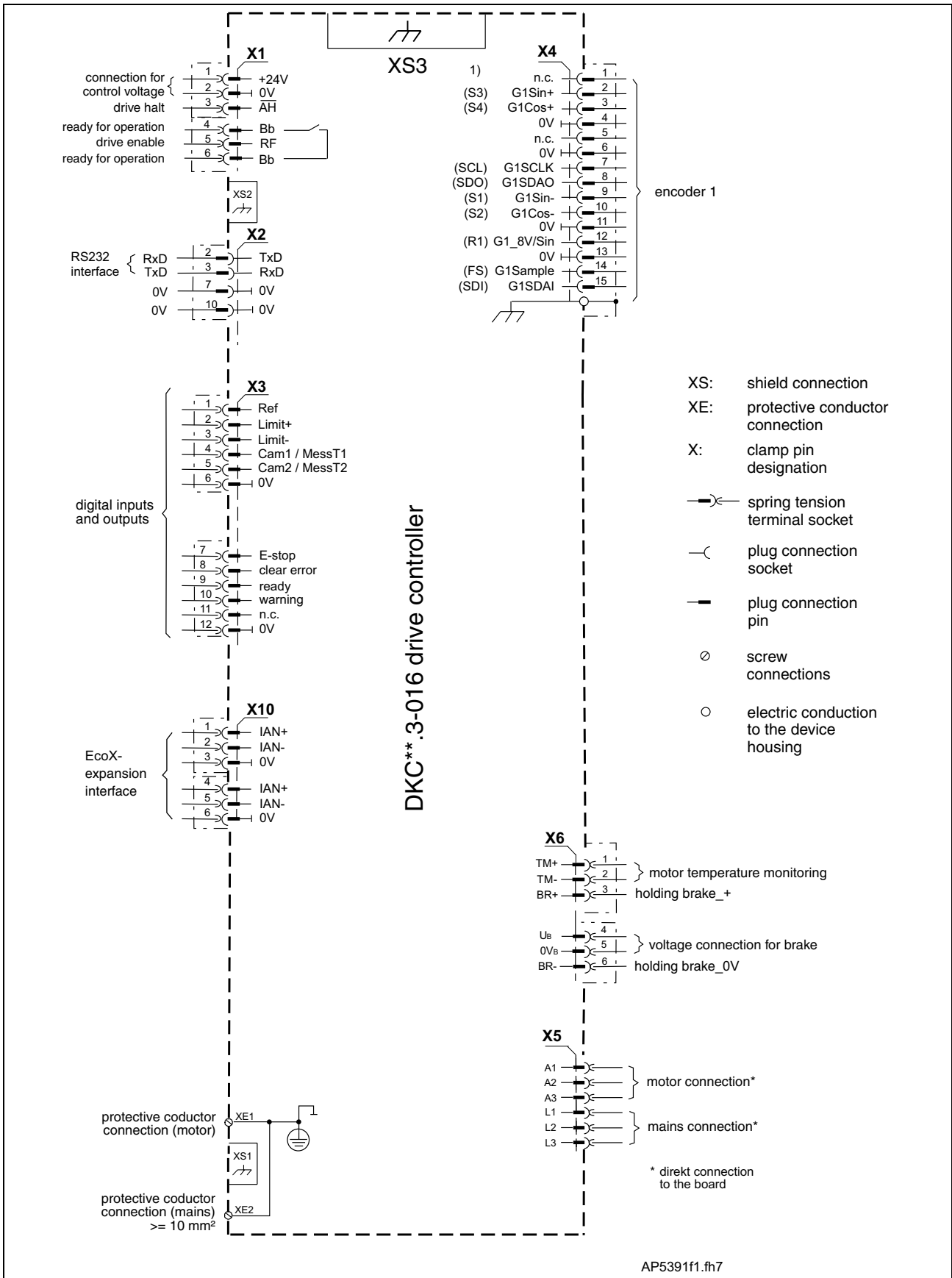

Fig. 5-21: Total connection diagram for DKC**.3-016

X1, Connections for control voltage

Technical description of connector

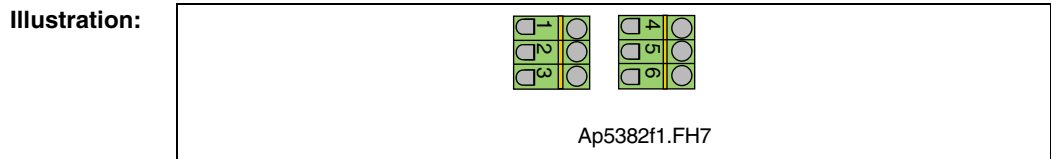

Fig. 5-22: Connector X1

Design:

Type	No. of pins	Design
Spring contact	2 x 3	Bushing on connector

Fig. 5-23: Design

Connection cross section:

Cross section single wire [mm ²]	Cross section multi core wire [mm ²]	Cross section in AWG Gauge no.:
0,2-2,5	1,5-2,5	16-12

Fig. 5-24: Connection cross section

24V control voltage supply (+24V and 0V)

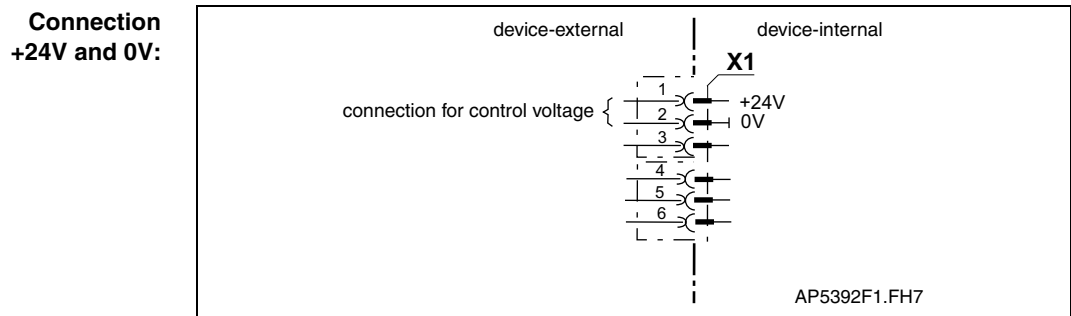

Fig. 5-25: Connections for control voltage

Connection loads +24V and 0V:

Voltage at X1/1 against X1/2:	see page 5-6 "Control voltage connection"
Current or power consumption X1/1:	
Reverse voltage protection:	Via allowed voltage range using internal protection diodes

Note: Strong mechanical influence on the test tap of the terminals can increase the transition resistance and destroy the terminals.

Note: The input 0 V is connected directly to the device potential. The utilization of an insulation monitoring for +24 V and 0 V against device is therefore not possible!

wire +24V and 0V:

wire cross section:	min. 1 mm ²
wire routing:	parallel if possible
Max. allowed inductance between 24V source and X1:	100 μH (equals about 2 x 75 m)

Note:

- Exceeding allowed control voltage generates error message "+24 volt error". (=> See also functional firmware description.)
 - Control voltage failure causes the running motor to coast torque-free (without brake).
-

**DANGER****Dangerous movements due to unbraked coasting of motor with control voltage failure!**

- ⇒ Personnel should not remain within the area of the machine with moving parts. Possible preventive steps against unauthorized access are:
 - protective fencing
 - bars
 - covers
 - light barriers
 - ⇒ The fences must be able to withstand the maximum possible force that the machine can generate.
-

Drive halt (AH) and Drive enable (RF)

Note:

- Inputs work with inactive bus communication.
- Inputs don't work with active bus communication (SERCOS interface, Profibus-DP, ...).

**Connection
AH and RF:**

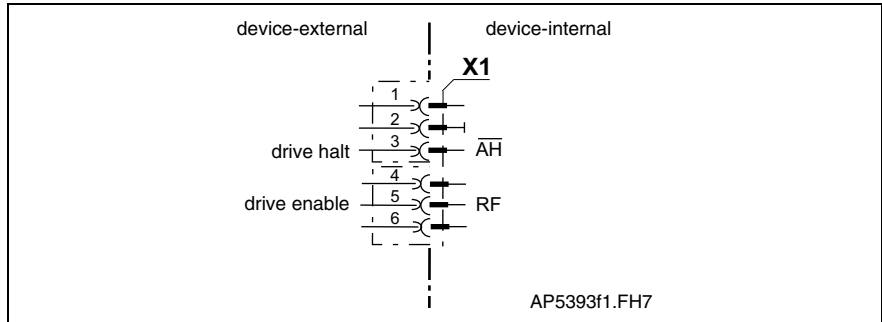
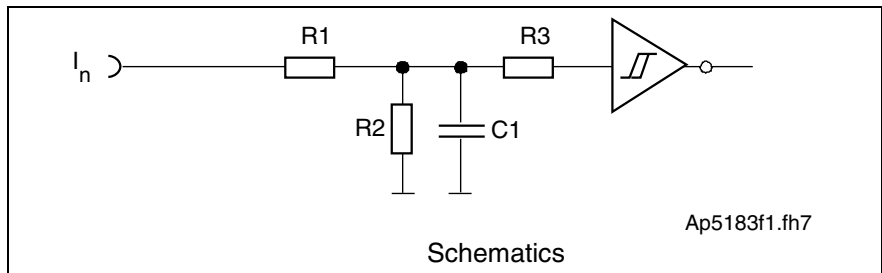

Fig. 5-26: Connections for drive halt and drive enable

**Input circuit
AH and RF:**



- R1: 10k
- R2: 3k3
- R3: 10k
- C1: no data

Fig. 5-27: Input circuit

**Inputs
AH and RF:**

Input voltage:	min.	max.
High	16 V	30 V
Low	-0.5 V	3 V
Input resistance	13.3 kOhm ± 5%	
Reaction time	See functional firmware description	

Fig. 5-28: Inputs

AH: The drive halt function is used to bring an axis to standstill with defined acceleration and jerk (see functional firmware description).

RF: The input drive enable (RF) activates the drive with a 0-1 edge.

Note: If the inputs are controlled by a power supply other than the DC24 volt supply of the DKC, then the reference lead of the other power supply must be connected to X1.2 (0 V).

Ready to operate contact Bb

Connection
Bb:

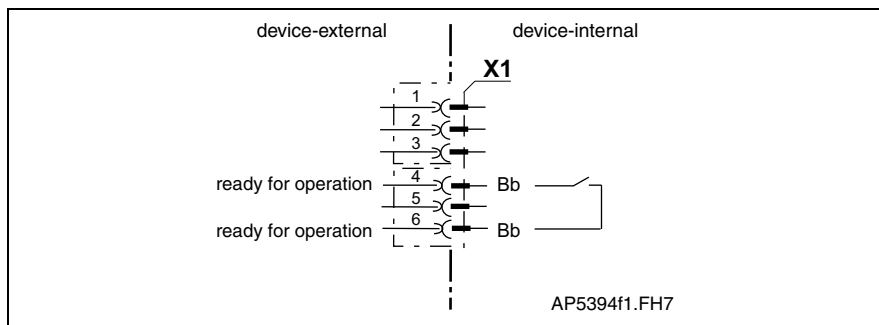

Fig. 5-29: Connections for ready to operate contact

Loadability of the connection
Bb:

Max. switching voltage:	DC 40 V
Max. switching current:	DC 1 A
Max. continuous current:	DC 1 A
Minimum contact load:	10 mA
Guaranteed number of switching operations at max. time constant of load < 50 ms:	250,000

Switching states
Bb:

The Bb contacts opens:

- if control voltage for DKC is not applied
- if 24 volts not present at the emergency stop input when the E-stop function is activated (depends on parameterization, see function description).
- With an error in the drive (depends on parameterization, see functional firmware description: "Power off on error").

How to use the contact, see page11-2: "Control Circuits for the Mains Connection"



WARNING

Damage possible if Bb contact not connected !

The ready to operate contact Bb acknowledges the drive is ready for mains voltage.

- ⇒ Integrate Bb contact as per "Control Circuits for the Mains Connection".
- ⇒ The evaluation of the Bb contact by a PLC may not cause any operating delay of more than 10 ms.

X2, Serial Interface

Note: Serial interfaces (RS232) are generally used for programming, parameterization and diagnoses upon commission and during service.

Technical description of connector

Illustration:

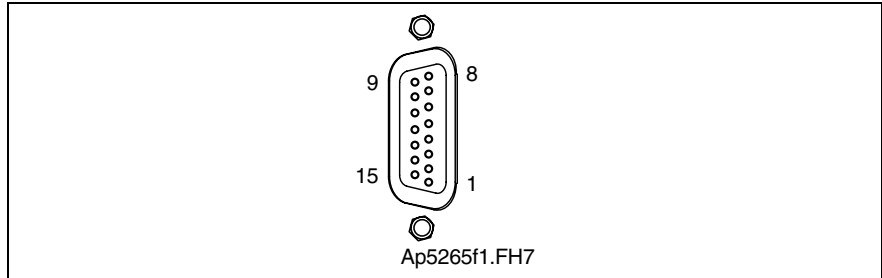

Fig. 5-30: Connector X2

Design:

Type	No. of pins	Design
D-SUB	15	Bushings on unit

Fig. 5-31: Design

Connection cross section:

Cross section single wire [mm ²]	Cross section multi core wire [mm ²]	Cross section in AWG gauge no.:
--	0.25-0.5	--

Fig. 5-32: Connection cross section

Short circuit protection:

RS232	pin 2, 3 against each other against 0 V	present present
-------	---	-----------------

Fig. 5-33: Short circuit protection

RS232 interface

The RS232 interface is used for programming, parameterization and diagnoses at start up and service.

It makes possible:

- a participant number of maximum 1
- a transmission length of up to 15 m
- transmission rates of 9600/19200 baud

Using an RS232 interface only one drive at a time can be parameterized with the DriveTop start up program.

Connection RS232:

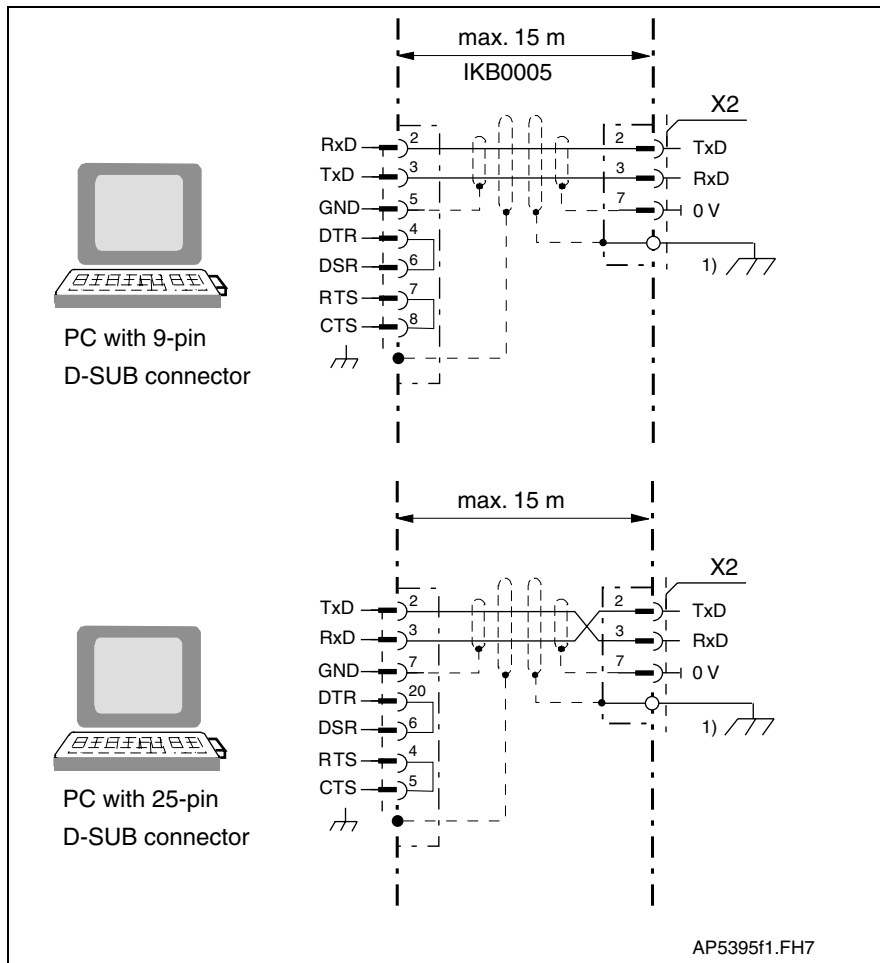

- 1) Connect the metallic connector case with the device potential using the fastening screws of the connector

Fig. 5-34: Connecting a PC to the RS232 interface on a DKC

See also page 13-4 "Additional Accessories".

X3, Digital I/Os

Technical description of connector

Illustration:

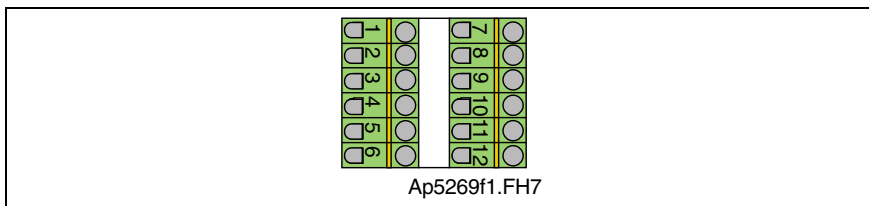

Fig. 5-35: Connector X3

Design:

Type	No. of pins	Design
Spring contact	2 x 6	Bushing on connector

Fig. 5-36: Design

Connection cross section:

Cross section single wire [mm ²]	Cross section multi core wire [mm ²]	Cross section in AWG Gauge no.:
0,2-2,5	0.2-1.5	24-16

Fig. 5-37: Connection cross section

Digital Inputs (Ref, Limit+, Limit-, Cam1/ MessT1, Cam2/ MessT2, E-stop, Clear error)

Connection Digital inputs:

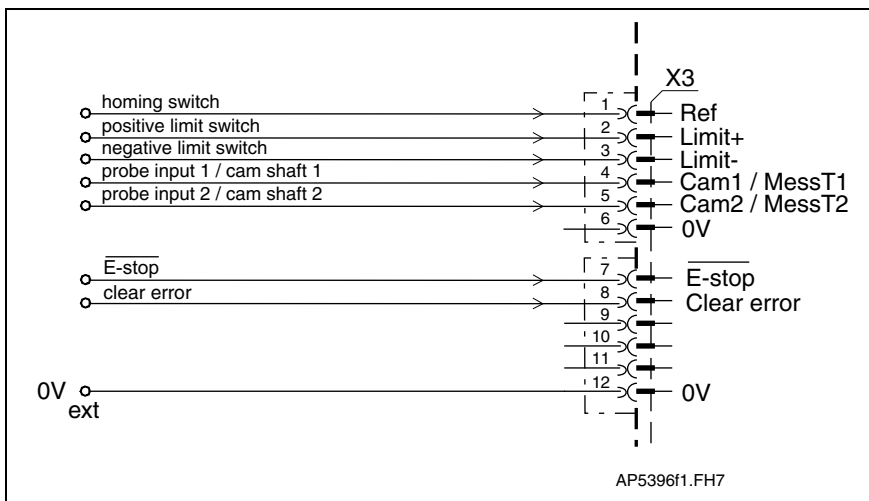
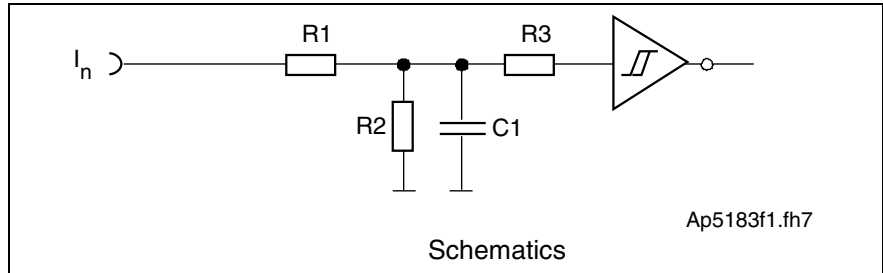

Fig. 5-38: Digital inputs

**Input circuit
Digital inputs:**



- R1: 10k
- R2: 3k3
- R3: 10k
- C1: no data

Fig. 5-39: Input circuit

**Inputs
Digital inputs:**

Input voltage:	min.	max.
High	16 V	30 V
Low	-0,5 V	3 V
Input resistance	13,3 kOhm ± 5%	
Reaction time	See functional firmware description	

Fig. 5-40: Inputs

Note: If the inputs are controlled by a power supply other than the DC24 volt supply of the DKC, then the reference lead of the other power supply must be connected to X3.12 (0 V).

- Homing switch:** The positive edge of the homing switch is always evaluated.
- Limit+, Limit-:** End switches can be N/C or N/O depending on how the drive is parametrized. See functional firmware description.
- Probes:** Position and time measurements are read using two binary input signals.
- Cams:** Switching-signal dependent continuous block switching makes transition to the next block possible with the use of an external switching signal.
- Note:** If the functions probe and following block mode are simultaneously activated, then both functions evaluate the inputs independently of each other.
- E-Stop:** At delivery, the E-stop function is deactivated depending on what has been parameterized. See functional firmware description.
- Clear error:** With a positive edge at the input "clear error", all errors (up to four) are cleared. With the actuation of the S1 button (firmware module) only the error in the display is cleared and any other errors present are then shown.
- Note:** The errors entered in the back-up memory are not cleared with the "clear error" input.

Digital outputs (ready and warning message)

Connection
Digital outputs:

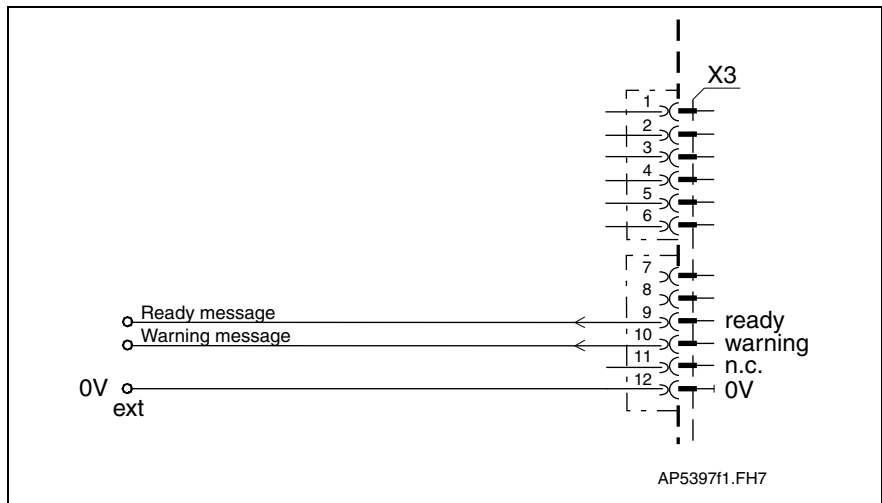
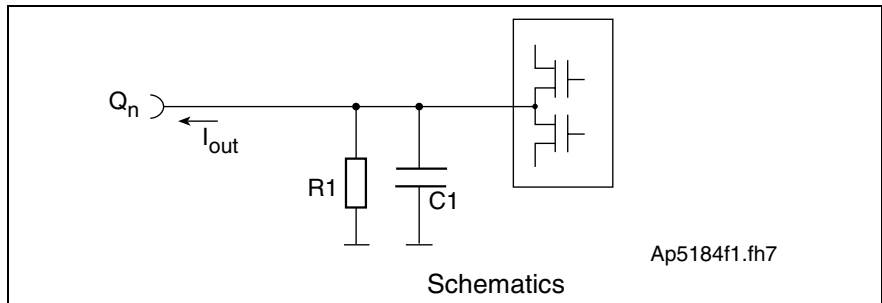

Fig. 5-41: Control outputs

Output circuit connection
Digital outputs:



R1: 20k
C1: no data

Fig. 5-42: Output circuit

Output connections
Digital outputs:

Output voltage:	min.	max.
High	16 V	U_{ext} (an X1.1) - 1 V
Low	-0.5 V	1.5 V
Output current I_{out}	80 mA	
Rise and drop time	about < 600 ns	
Overload protection	- short circuit protection - thermal shutdown	

Fig. 5-43: Outputs

Warnings: Depending on operating mode and parameter programming a number of monitoring functions are conducted. If a condition is detected that still allows for correct operations but would eventually lead to an error, then the warning is set to high.

⇒ See also functional firmware description.

Ready: If the unit is ready for the drive enable, then the output ready is set to high.

The output is set to low

- with a pending error
- with DC bus voltage < (0.75 x threshold value of applied mains voltage)
- with lacking control voltage

⇒ See also functional firmware description: "Ready"

X4, Encoder 1

Technical description of connector

Illustration:

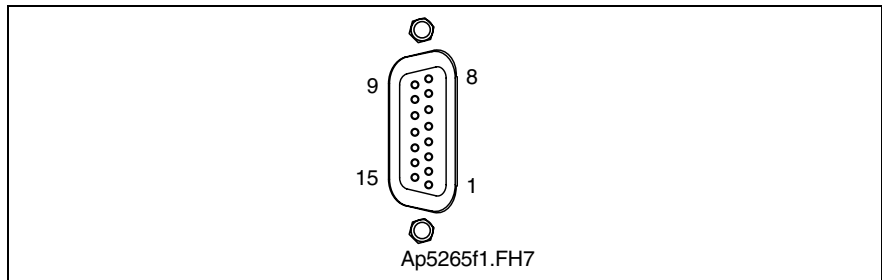

Fig. 5-44: Connector X4

Design:

Type	No. of pins	Design
D-SUB	15	bushing on unit

Fig. 5-45: Design

Connection cross section:

Cross section single wire [mm ²]	Cross section multi core wire [mm ²]	Cross section in AWG gauge no.:
--	0.25-0.5	--

Fig. 5-46: Connection cross section

Connection Encoder 1:

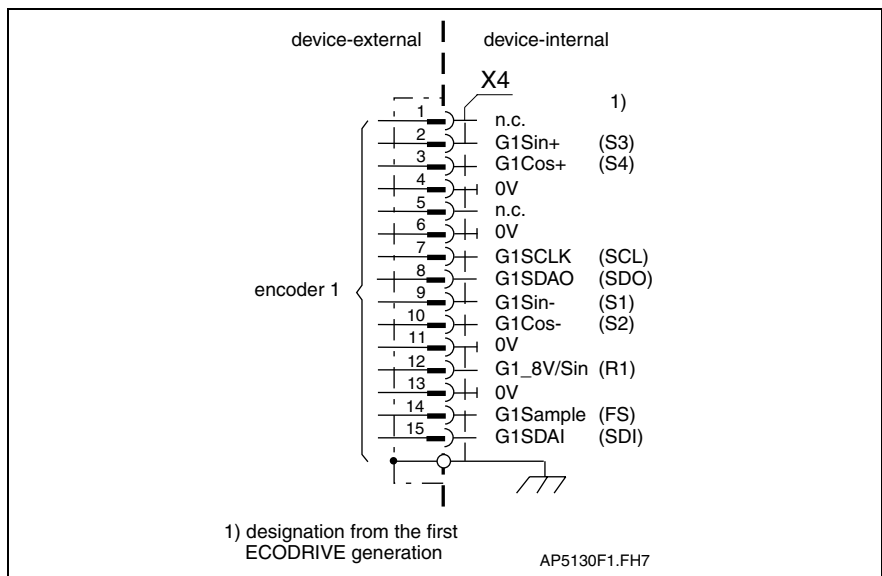

Fig. 5-47: Encoder 1

Shield connection: Via D-subminiature mounting screws and metal connector housing.

G1SCLK: Clock lead for I²C interface

G1SDA0, G1SDAI: Data lead for I²C interface

G1Sample: Control signal for encoder initialization

G1Sin+ (S3), G1Sin- (S1): Input circuit G1Sin+ (S3), G1Sin- (S1):

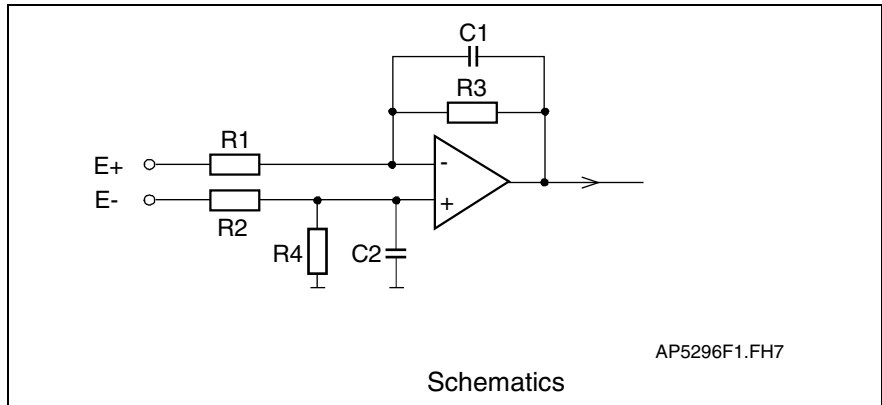

- R1: 4k
- R2: 4k
- R3: 8k25
- R4: 8k25
- C1: no data
- C2: no data

Fig. 5-48: Input circuit

Features of the differential input circuit G1Sin+ (S3), G1Sin- (S1):

	Resolver
max. allowed amplitude encoder signal	9,0 Vss
Evaluation AD converter	12 Bit
Limit frequency	--
Input resistance	8k ± 5%

Fig. 5-49: Features of the differential input circuit

G1Cos+ (S4), G1Cos- (S2): see G1Sin+ (S3), G1Sin- (S1)

G1_8V/Sin: Features of the encoder output amplifier stage G1_8V/Sin:

	Resolver
Output voltage	18,2 Vss (sine with 4 kHz)
max. output current	AC 70 mA eff.
min. D.C. resistance of the load	35 R

Fig. 5-50: Features of the encoder output amplifier stage

Signal allocation to the actual position value

Signal allocation (X4)	signal designation	signal form	actual position value (with default setting)
 <p>amplitude-modulated signal</p>	<p>G1Sin+(S3)</p> <p>G1Sin- (S1)</p> <p>G1Cos+(S4)</p> <p>G1Cos- (S2)</p> 	Resolver	increasing

Fig. 5-51: Signal allocation to the actual position value

Note: default setting:
=> see functional firmware description: "Motor Encoder" (Encoder 1).

Connecting the Measuring System

See page 1-4 "An Overview of Measuring Systems Supported".

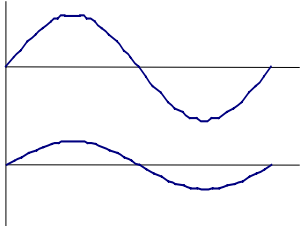
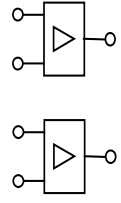
X5, Motor and Mains Connections



DANGER

Lethal electric shock caused by live parts with more than 50 V!

- ⇒ Before working on the drive controller, switch off the power supply via the main switch or the fuse.
- ⇒ Always mount or dismount both connectors (motor connector and mains connector) on the drive controller at the same time.
- ⇒ Observe the information contained in chapter 3 "Safety Instructions for Electric Drives and Controls".

Technical description of connector

Illustration:

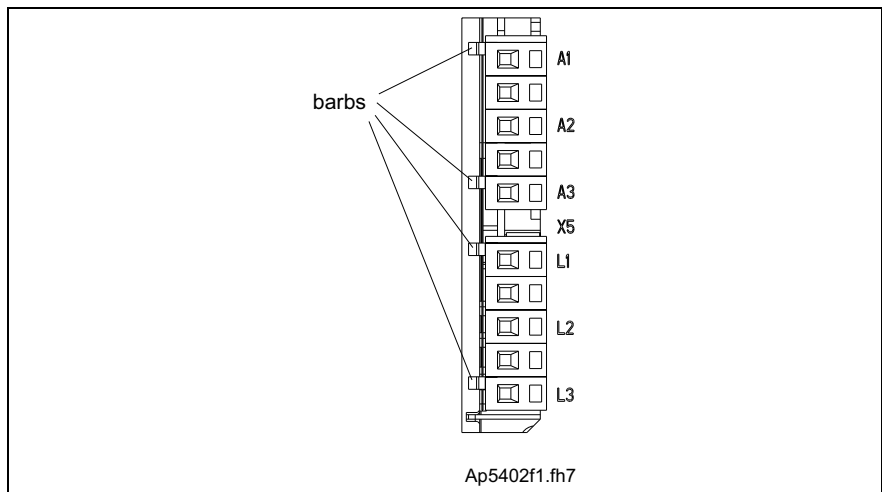

Fig. 5-52: Connector X5

Note:

- To pull off the connectors, loosen the barbs.
- The maximum number of insertion/withdrawal cycles is limited to 15.

Design:

Type	No. of pins	Design
connection block	2 x 3	bushing on connector

Fig. 5-53: Design

Connection cross section:

Cross section single wire [mm ²]	max. connectable cross section [mm ²]	max. Cross section in AWG gauge no.:
1,5	1,5	16

Fig. 5-54: Connection cross section

Motor connection

Connection Motor:

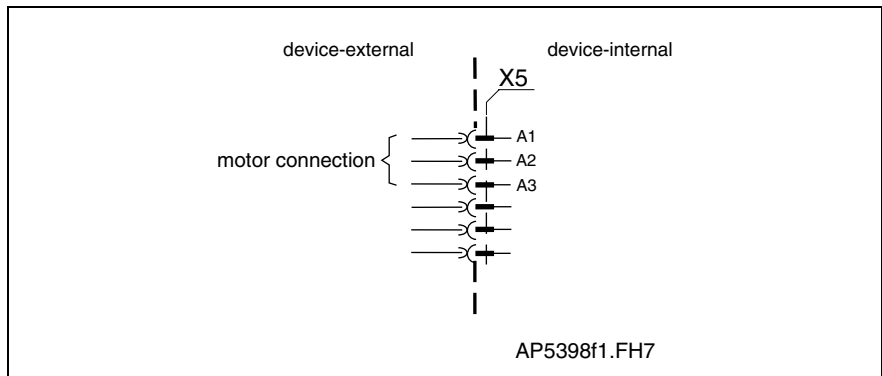

Fig. 5-55: Motor connections

Cable Motor: Use Rexroth Indramat motor power cables to connect motor and controller.

Note: For technical data on connections and cross sections, see the motor project planning manual.

Cable length:

Maximum length equals 35 m:

- With two connections between controller and motor (e.g., plugs at exit of control cabinet and at machine)
- Standard cables from Rexroth Indramat and
- Ambient temperatures of $\leq 40\text{ }^\circ\text{C}$ per EN 60 204
- Switch frequency of 4 kHz

Maximum allowed capacitance per unit length at A1, A2, A3:

- with regard to ground: 0.5 nF/m
- cable to cable: 0.5 nF/m

Maximum allowed inductance per unit length an A1, A2, A3:

- 100 nH/m

To maintain EMC values, the motor cable length is limited with a switching frequency of $> 4\text{ kHz}$. It is largely dependent on the application and ambient conditions at the installation and machine.

A guide value is listed below:

Cycle frequency drive controller	Max. length for class B, EN 55011	Max. length for class A, EN 55011
standard setting switching frequency 4 kHz	35 m	35 m
parameter setting switching frequency 8 kHz	35 m	35 m

Fig. 5-56: Guide value for maximum motor cable lengths

**WARNING****No guarantee!**

If third party cables are used, then the guarantee is forfeited for the entire system.

⇒ Use Rexroth Indramat cables!

Illustration of the correctly connected motor cable: See page 16-19
Connection of motor and mains cable DKC**.3-016-7".

Mains connections

The mains connector serves as the connection of the drive controller with the power supply.

Single-phase mains connection:

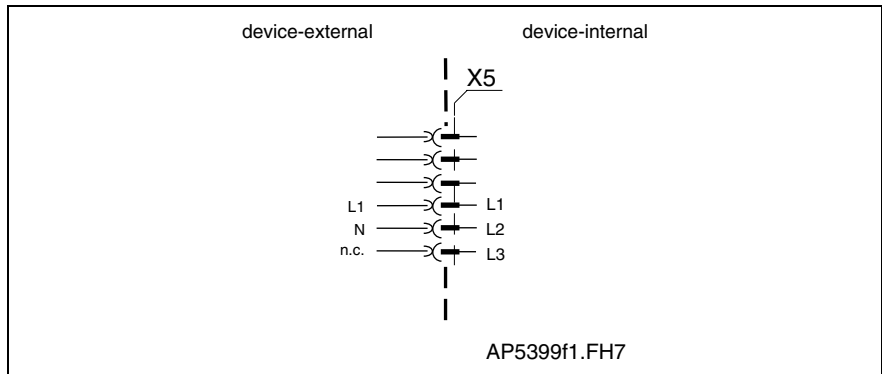

Fig. 5-57: Single-phase mains connection

Three-phase mains connection:

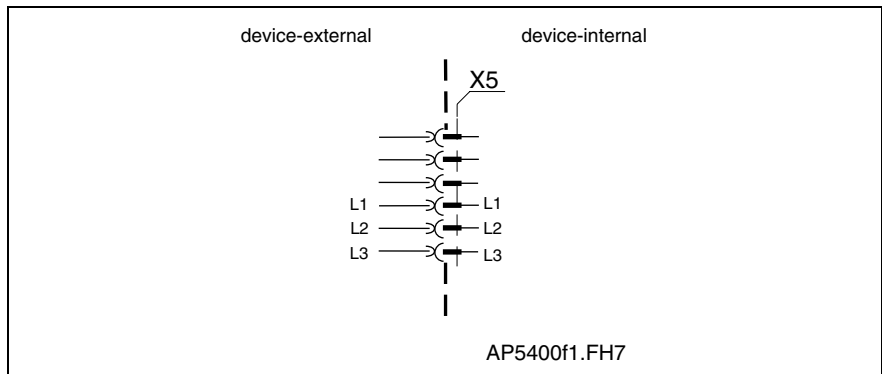

Fig. 5-58: Three-phase mains connection

Note: Mains connections should not be daisy-chained between the units (intermediate connectors for the supply source should be used).

Illustration of the correctly connected mains cable: See page 16-19 Connection of motor and mains cable DKC**.3-016-7".

See also page 11-1 "Mains Connections"

X6, Motor temperature monitoring and holding brakes

Technical description of connector

Illustration:

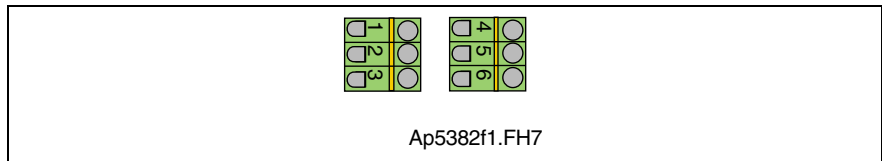

Fig. 5-59: Connector X6

Design:

Type	No. of pins	Design
Spring contact	2 x 3	Bushing on connector

Fig. 5-60: Design

Connection cross section:

Cross section single wire [mm ²]	Cross section multi core wire [mm ²]	Cross section in AWG Gauge no.:
0.2-2.5	1.5-2.5	16-12

Fig. 5-61: Connection cross section



CAUTION

Damages by exchanging the connectors X6.1-3 and X6.4-6!

- ⇒ Do not exchange connectors X6.1-3 and X6.4-6.
- ⇒ Only use lines with sufficient cross section.
- ⇒ Strong mechanical influence on the test tap of the terminals can increase the transition resistance and destroy the terminals.

Motor temperature monitoring (TM+, TM)

Connections TM+ and TM- are used to evaluate the temperature of connected Rexroth Indramat motors. These are equipped with a temperature-dependent resistor (either PTC or NTC dependent on the motor type) to monitor temperature. The connection leads are in the motor power cable.

Connection monitoring TM+, TM-:

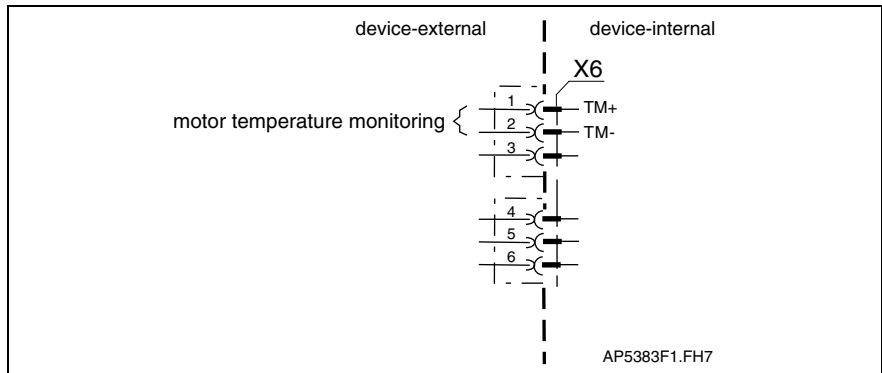
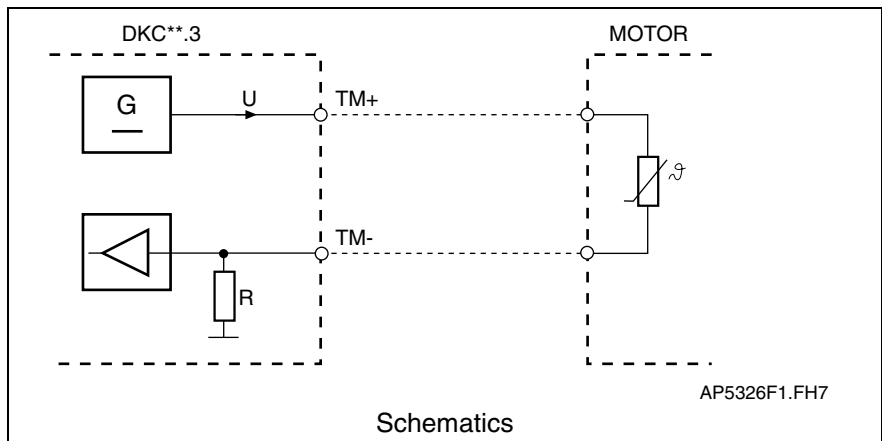

Fig. 5-62: Motor temperature monitoring

Motor temperature evaluation:



U: approximately 5V
R: approximately 2k

Fig. 5-63: Motor temperature evaluation

Note: Connections TM+ and TM- are only to be used with Rexroth Indramat motors.

⇒ See also functional firmware description: "Temperature monitoring".

Holding brake (BR+, BR-)



Dangerous movements! Danger to personnel from falling or dropping axes!

- ⇒ The standard equipment motor brake or an external brake controlled directly by the servo drive are not sufficient to guarantee the safety of personnel!
- ⇒ Personnel safety must be acquired with higher-ranking procedures:
 - Dangerous areas should be blocked off with fences or grids.
 - Secure vertical axes against falling or slipping after switching off the motor power by, for example:
 - Mechanically securing the vertical axes
 - Adding an external brake / clamping mechanism
 - Balancing and thus compensating for the vertical axes mass and the gravitational force

These control the holding brakes in the connected motors.

For the switching performance, see function description.

To connect external loads note allowed contact loads.

**Connection
BR+, BR-:**

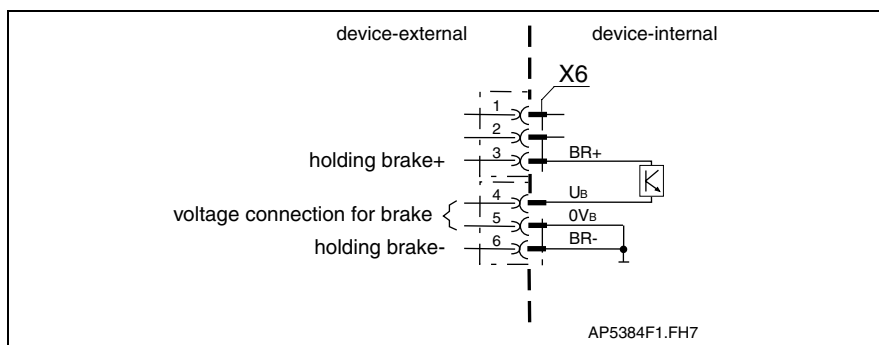

Fig. 5-64: Holding brake and voltage connection

Loadability of connections BR+, BR-:

max. switching voltage:	DC 36 V
max. switching current:	DC 1 A
max. continuous current:	DC 1 A
Minimum contact load:	100 mV
Guaranteed number of switches at max. time constant of load < 50 ms ($L_{\text{Bremsel}}/(24V/I_{\text{Bremsel}})$):	unlimited (electronic contact free of wear)
Short-circuit and overload protection in the row to the contact	present

Voltage connection for brakes

Note: The motor holding brake is not supplied by the controller. Given one voltage source for brake and control voltage, use parallel leads from the voltage source. Note the voltage range for the motor holding brake according to the motor projection.

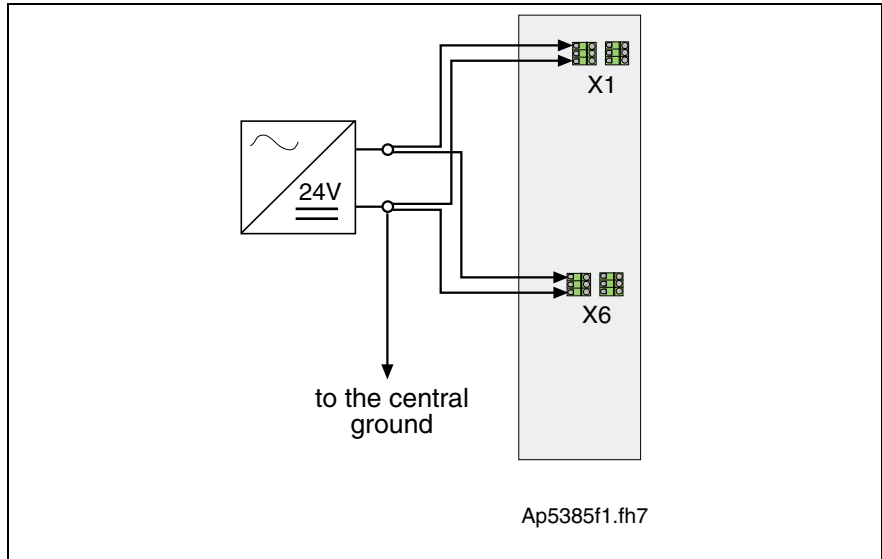

Fig. 5-65: Shared voltage source for brakes and control voltage supply

Note: Looping through the voltages to other drive controllers is impossible. Other drive controllers have to be connected in radial arrangement around the voltage source.

Voltage connection for brakes on DKC:

max. voltage at X6.4 against X6.5:	DC 36 V
current consumption at X6.3 and needed supply voltage:	see "Technical data" brake in the motor manual

wire voltage connection for brake:

wire cross section:	min. 1 mm ²
voltage resistance of single wire to ground	≥ 750 V (e.g.: litz wires - H07)
wire routing	parallel if possible (twisted)
max. inductance between 24 V source and X6	100 μH (equals about 2 x 75 m)

Motor holding brake

Controlling the motor holding brake:

The controller controls the holding brake.

Technical data Motor holding brake:

Supply voltage, current consumption, linking, separating time, holding torque, etc. see motor manual.

Basic connection of motor power, holding brake and motor temperature monitoring

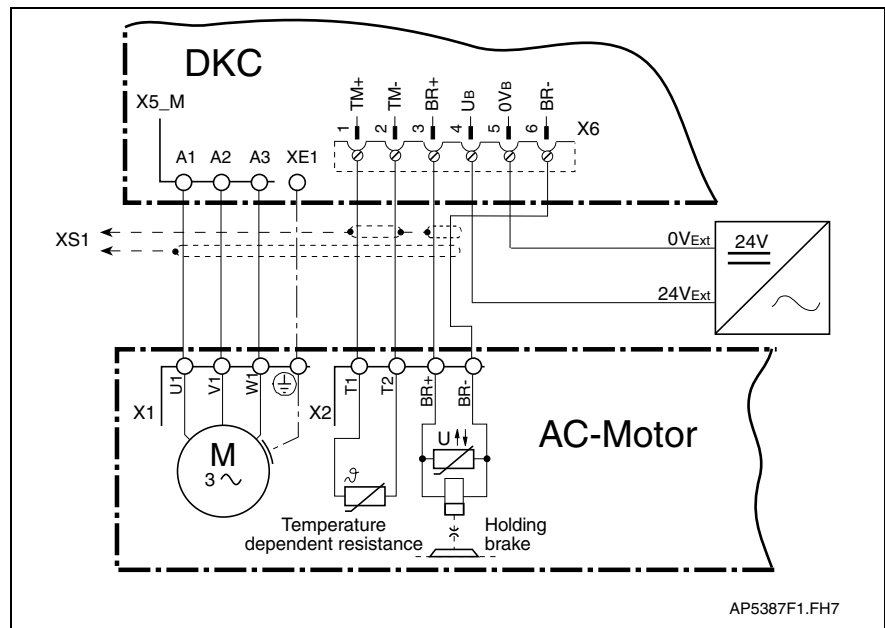

Fig. 5-66: Connection of motor cable, holding brake and temperature monitor for motors with connector box

Note: The cable designations and all details on making cables are outlined in the cable or motor document.

X10, EcoX Expansion interface

See page 4-86.

XE1, XE2 Protective conductor connections for motor and mains

Technical description of connector

Illustration: See page 5-16: "A look at the drive controller and connector designations".

Design:	Type	No. of pins	Design
	screw-in connection	2 x 1	screw-in connection for ring terminals M5

Fig. 5-67: Design

Tightening torque:	min. tightening torque [Nm]	max. tightening torque [Nm]
	2.5	3.0

Fig. 5-68: Tightening torque

Connection cross section:	Cross section single wire [mm ²]	Max. connectable cross section in mm ²	Max. cross section in AWG gauge no.:
	--	25	--

Fig. 5-69: Connection cross section

XE1, Protective conductor connection for motor

See page 5-33: "Motor connection".

XE2, Protective conductor connection for mains

Note: PE connection $\geq 10 \text{ mm}^2$
Reason: high leakage currents (EN 50178/1998, section: 5.3.2.1)

XS1, XS2, XS3 Shield Connections

XS1

Connection for shield:

- Total motor cable shield
- Holding brake
- Motor temperature monitoring

XS2

Connection for shields of cables at X1 and those for the command communication interfaces.

XS3

Connection for shields of cables at X3 and X10.

Allowed outside diameter: 6 - 15 mm (for all shield connections)

Note: Always connect the shield connections of the cables (especially of the motor cables) with a large contact surface.

H1, S1, S2, S3: Diagnostic display, Reset key, Address switch

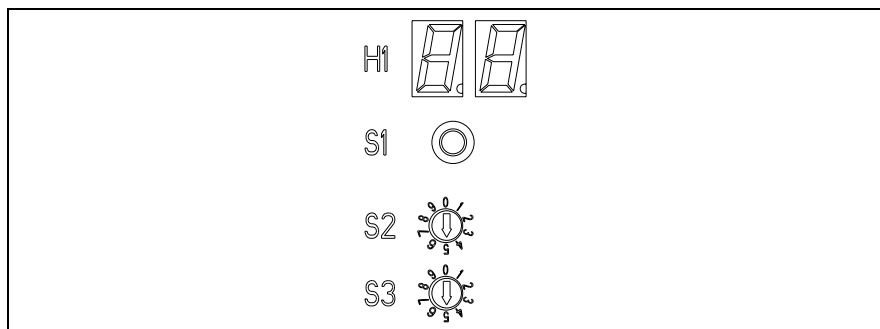

Fig. 5-70: H1: Diagnostic display, S1: Reset key, S2, S3: Address switch

H1

Number of diagnostic messages (errors and operating states).

S1

- Key for resetting diagnostic displays of errors
- Key for updating firmware

S2, S3

Switch for setting the drive address.

**Address switch S2, S3;
Drive address** Two decade switches are used to set the drive address. It can be set to any number between 1 and 99.

Example:

Switch setting S3 = 9 (value of tens)

Switch setting S2 = 1 (value of ones)

Drive address = $9 * 10 + 1 = 91$

Note: The address is not set at delivery.

The setting of switches S2 and S3 depends on the model, firmware and the drive address wanted.

⇒ see functional firmware description

Setting the Drive Address

Switch S2, S3 drive address Two decade switches are used to set the drive address. It can be set to any number between 1 and 99.

Example:

Switch setting S3 = 9 (value of tens)

Switch setting S2 = 1 (value of ones)

Drive address = $9 * 10 + 1 = 91$

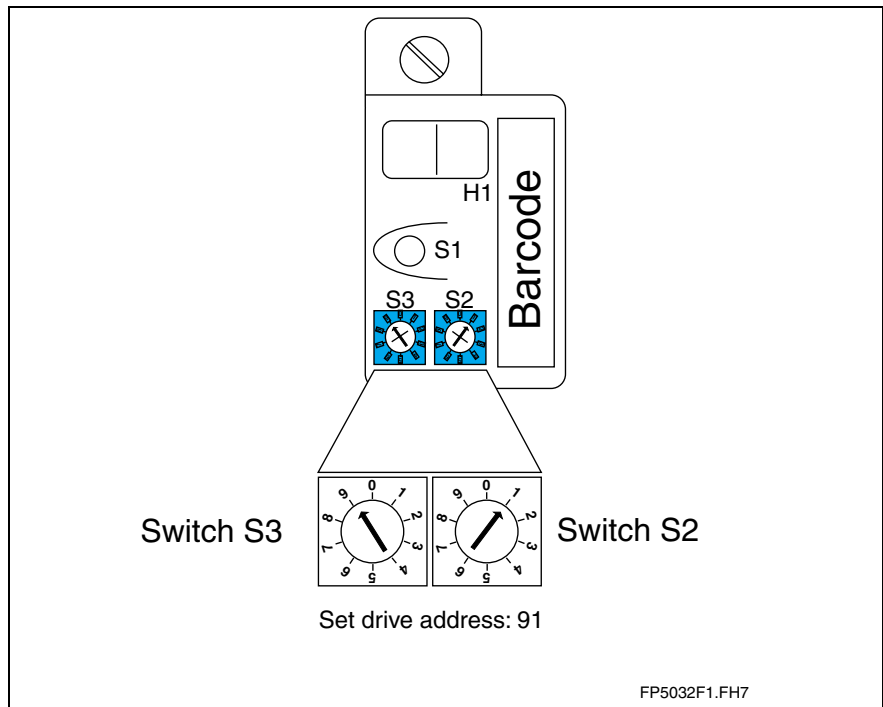

Fig. 5-71: Setting the drive address using a decade switch

Note: The address is not set at delivery.
The setting of switches S2 and S3 depends on the model, firmware and the drive address wanted.

⇒ See functional firmware description.

Notes

6 ECDRIVE03 Auxiliary Bleeder Module BZM01.3

6.1 General

The Auxiliary Bleeder Module BZM01.3 is advantageously utilized to:

- To increase the allowed continuous regenerative power
- To increase the allowed peak regenerative power
- For internal DC bus dynamic brake (ZKS) with DKC**.3-040-7-FW

6.2 Technical data

Dimensions

Dimensions Auxiliary Bleeder Module BZM01.3

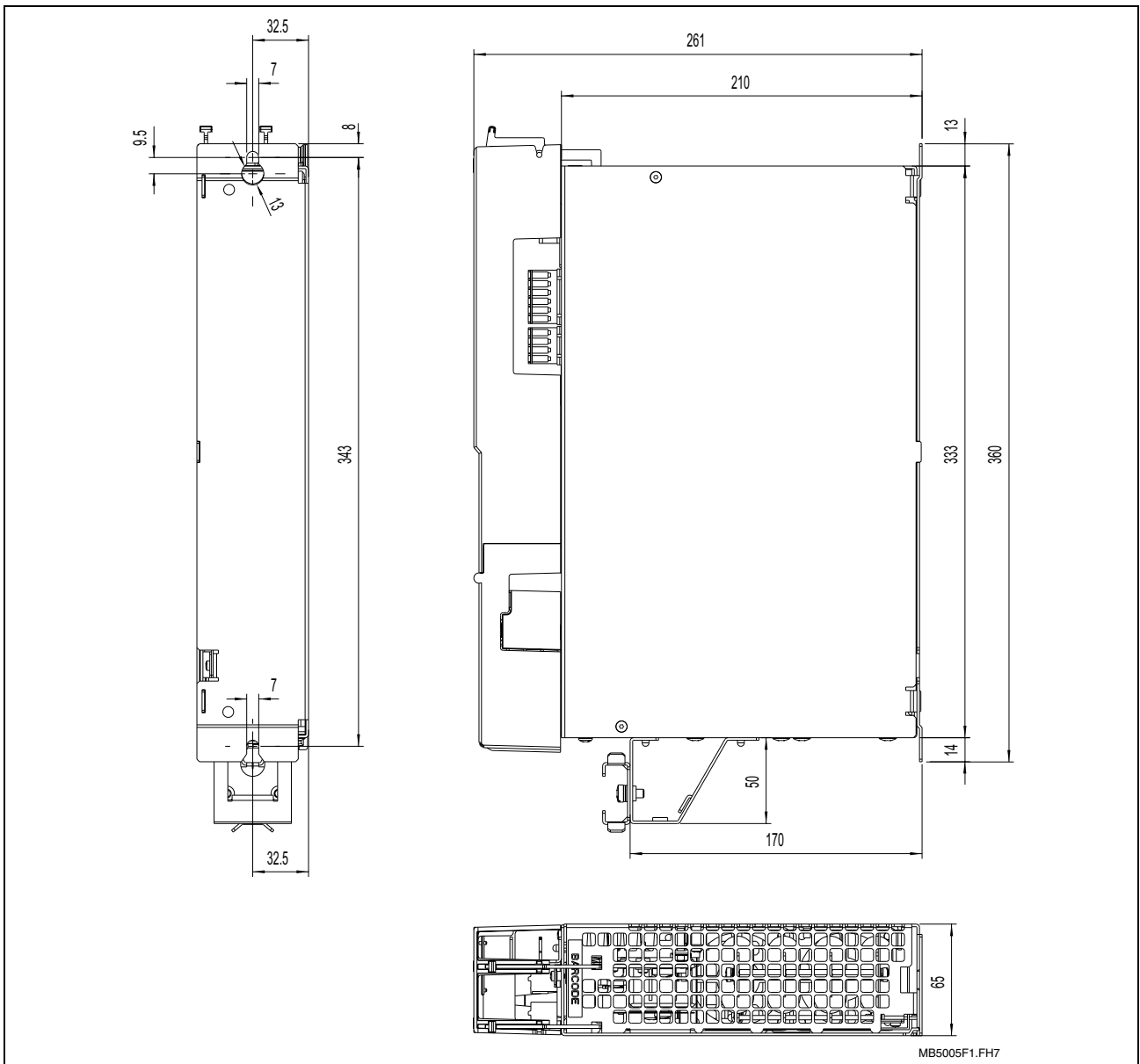

Fig. 6-1: Dimensions Auxiliary Bleeder Module BZM01.3

Also see page 12-1: "Constructing the Control Cabinet".

Materials used, Mass

Designation	Symbol	Unit	BZM01.3
Mass	m	kg	6.5
Materials	-	-	asbestos and silicone free

Fig. 6-2: Materials used, Mass

Ambient and operating conditions

See page 4-4: "Ambient and operating conditions"

Electrical data of auxiliary component BZM01.3

Power section

Designation	Symbol	Unit	BZM01.3	
Operating mode at the mains			single phase	three phase
			The connection is for protection purposes. See page 6-14: "ZKS control input" and page 11-5: "Control Circuits with internal DC bus dynamic brake (ZKS)"	
Nominal charging current (dependent on mains input voltage)	I_{EIN1}	A	~ 0	
Mains input voltage	U_{N1}	V	See page 4-6: "Mains connections, Power section"	
Mains frequency	f_{N1}	Hz		
Rotary field			clockwise or counter-clockwise	
Device power dissipation without internal continuous bleeder power	P_{V}	W	12	
Peak bleeder power BZM	$P_{\text{BS,BZM}}$	kW	120	
Continuous bleeder power BZM when $T_{\text{a}} \leq 45^{\circ}\text{C}$ under max. temperature range at a distance	$P_{\text{BD,BZM}}$	kW	1	
	ΔT d	K mm	110 80	
max. available continuous bleeder power in the DC bus if operating: 1 x DKC**.3-040-7 1 x DKC**.3-100-7 1 x DKC**.3-200-7		kW	0.92	
		kW	1.2	
		kW	1.6	
with symmetry factor	f		0.8	
Max. energy Max. energy dissipation BZM	$W_{\text{R,MAX,BZM}}$	kWs	100	
Internal DC bus dynamic brake (ZKS)			contained	
nominal DC bus capacitance BZM	C_{ZW}	mF	0.33	
Allowed input voltage at L+, L- at X5	U_{ZW}	V	DC bus voltage ECODRIVE DC (300 ... 800)	
Cooling power section and bleeder resistor			with internal blowers	
Volumetric capacity of the forced cooling		m ³ /h	approx. 48	
Insulation resistance at DC500V	R_{is}	MOhm	> 15	

Fig. 6-3: Technical data mains connection and power section

DC24V voltage supply for BZM01.3

Designation	Symbol	Unit	BZM01.3
Input voltage	U_{N3}	V	see page 4-13 Control voltage connection for DKC"
maximum ripple effect	w	%	
max. allowed overvoltage	U_{N3max}	V	
current consumption	I_{N3}	A	0.5
max. charging current	I_{EIN3}	A	2.4
max. input capacitance	C_{N3}	mF	$0.22 * 1.2$

Fig. 6-4: Control voltage connection for BZM01.3

Amplitude of the BZM control voltage charging current at startup, to selecting power source

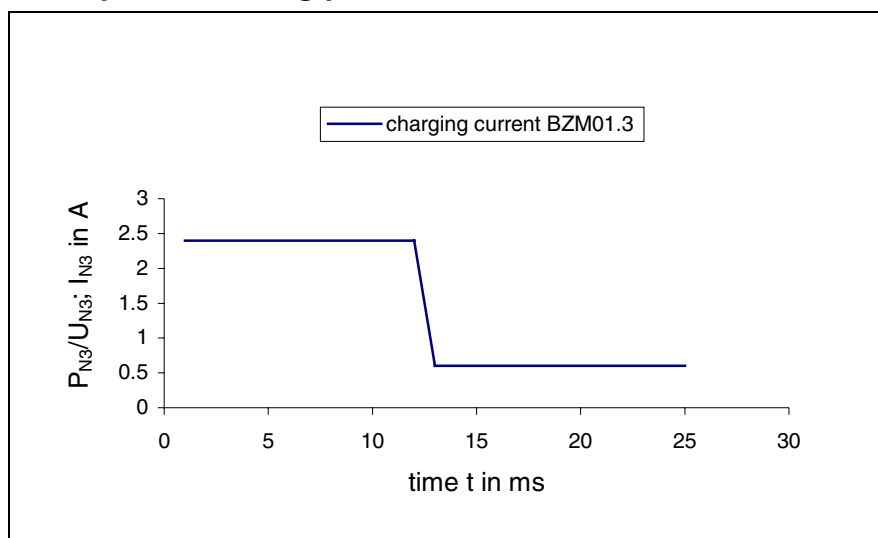

P_{N3} : Power consumption

U_{N3} : Control voltage

I_{N3} : Current consumption after charging current inrush

Fig. 6-5: Example of charging current inrush of control voltage

Note: For n parallel-switched inputs the charging current inrush is n-fold.

CE Label, Tests

CE label:

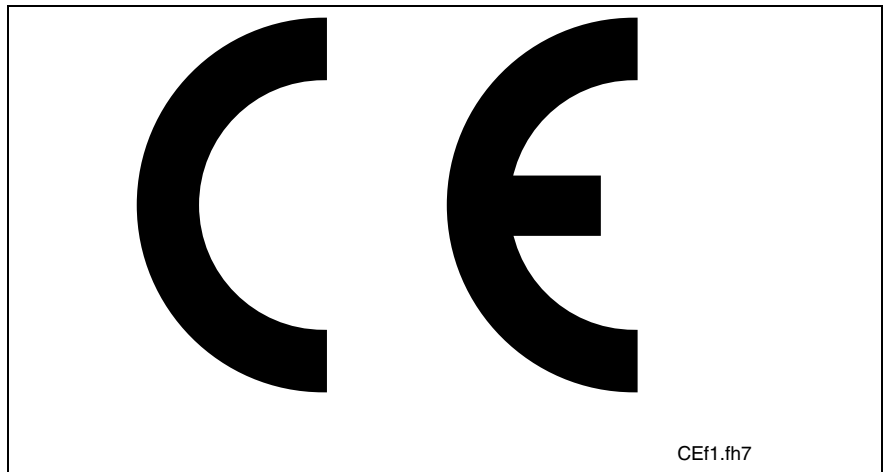

Fig. 6-6: CE marking

Tests:

High-voltage test according to EN50178	Routine test with DC2100V	1 s
Insulation test according to EN50178	Routine test with DC500V	1 s
Separation between the electrical circuits of the control and high voltage power	safe separation according to EN50178	
Clearances and creepage distances	according to EN50178	

Fig. 6-7: Tests

6.3 Electrical Connections BZM01.3

Front View

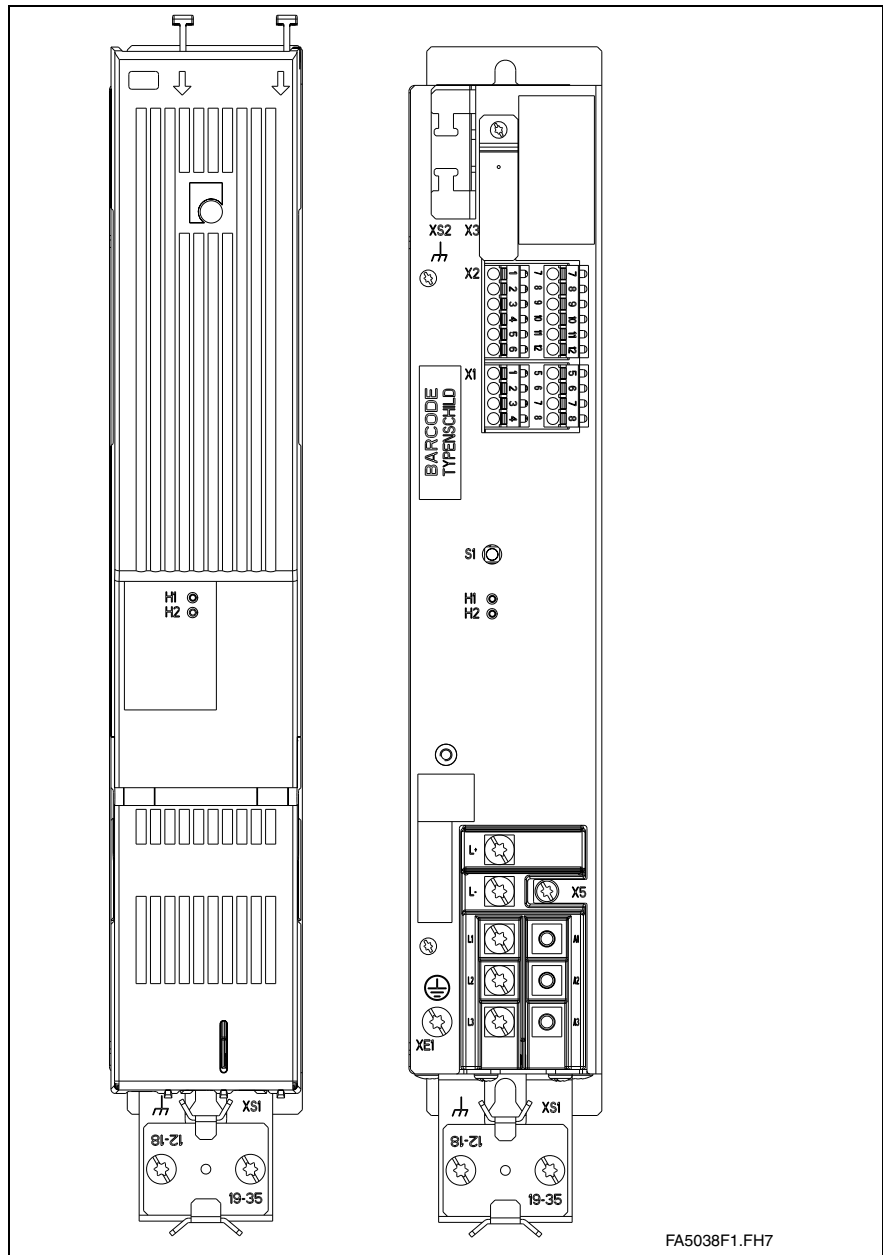

Fig. 6-8: Front view Auxiliary Bleeder Module BZM01.3

- S1: Reset key
- H1: Diagnosis green
- H2: Diagnosis red

Complete Terminal Diagram

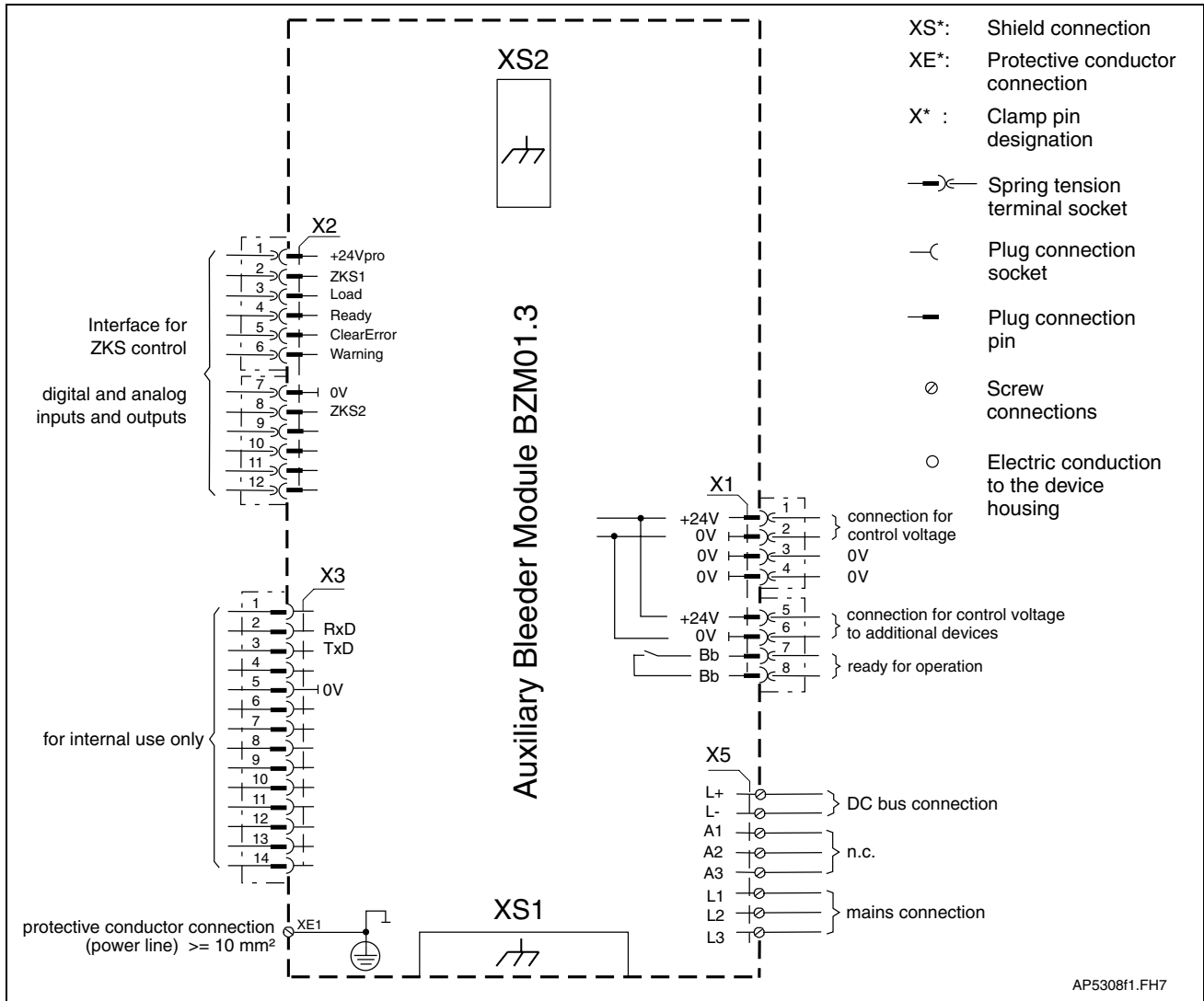

Fig. 6-9: Terminal diagram - BZM01.3

**CAUTION**

Mains power not applied to L1, L2, L3 causes damages to the drive controller device and to the BZM!

⇒ Apply switched mains power
see also page 6-15: "Fig. 6-25: Block diagram interlock ZKS/Mains".

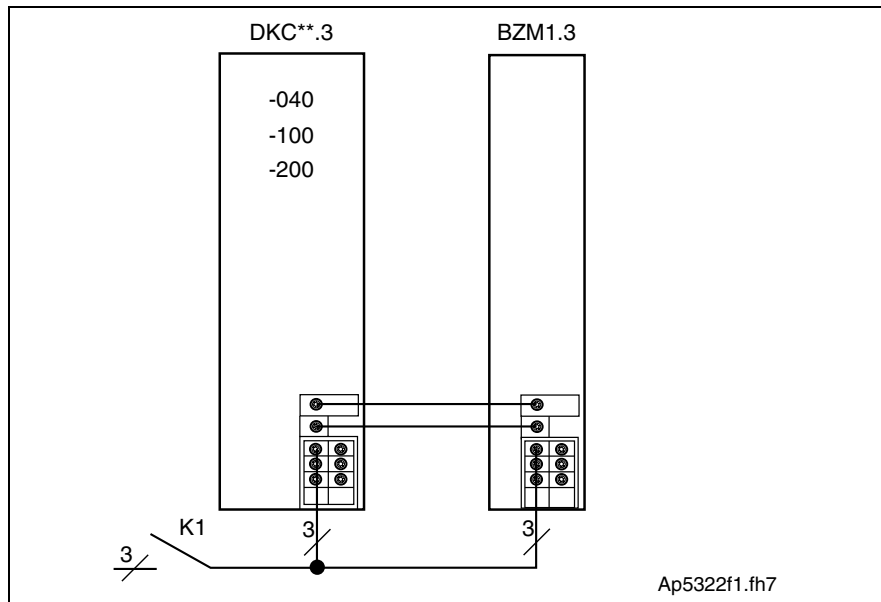

Fig. 6-10: DC bus and mains connection

Note: In addition to the illustrated connections of the BZM01.3 at the DC bus, the following connections must be wired as well:

- Bb contact
- control voltage supply

X1, Control voltage connections

Technical description of connector

Illustration:

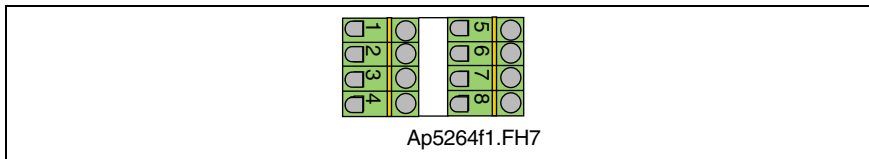

Fig. 6-11: Connector X1

Design:

Type	No. of pins	Design
spring contact	2 x 4	bushing at connector

Fig. 6-12: Design

Connection cross section:

Cross section single wire [mm ²]	Cross section multi core wire [mm ²]	Cross section in AWG gauge no.:
0.2-2.5	0.2-1.5	24-16

Fig. 6-13: Connection cross section

24V control voltage supply (+24V and 0V)

Connection +24V and 0V:

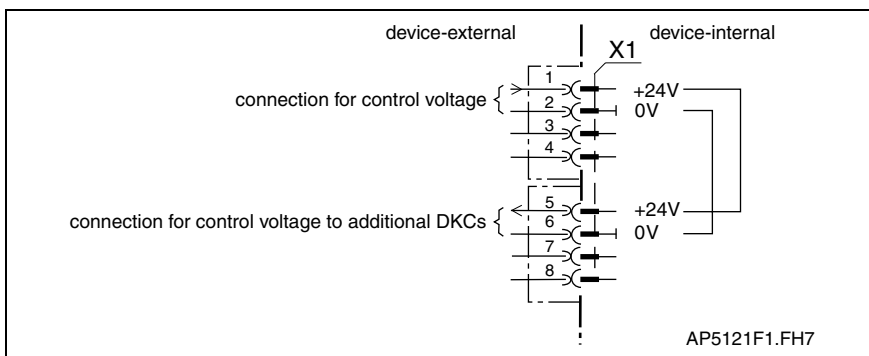

Fig. 6-14: Connections for control voltage

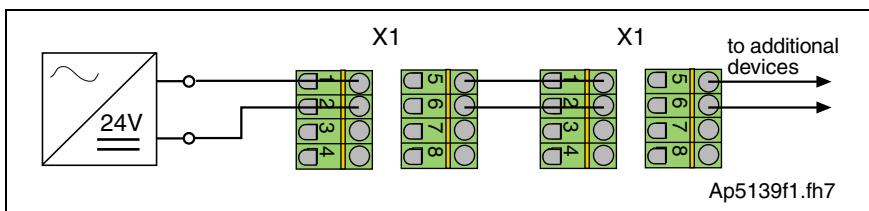

Fig. 6-15: Looping through the control voltage

**Load capacity of connection
+24V and 0V:**

Voltage at X1/1 against X1/2:	see page 4-13 Control voltage connection for DKC"
Reverse voltage protection:	Via allowed voltage range using internal protection diodes
Current or power consumption X1/1:	See page 6-5 : "Technical data → DC24V voltage supply for BZM01.3"
Max. allowed current load with looping through the control voltage via X1.1/2 to X1.5/6:	DC 10 A

**wire
+24V and 0V:**

wire cross section:	min. 1 mm ²
wire routing:	parallel if possible
Max. allowed inductance between 24V source and X1:	100 μH (equals about 2 x 75 m)

Note:

- Bleeder not available once control voltage fails.
- Control voltage failure causes the running motor to coast torque-free (without brake).
See page 11-5: "Control Circuits with internal DC bus dynamic brake (ZKS)"



DANGER

Dangerous movements due to unbraked coasting of motor with control voltage failure!

- ⇒ Personnel should not remain within the area of the machine with moving parts. Possible preventive steps against unauthorized access are:
 - protective fencing
 - bars
 - covers
 - light barriers
- ⇒ The fences must be able to withstand the maximum possible force that the machine can generate.

Ready to operate contact Bb

**Connection
Bb:**

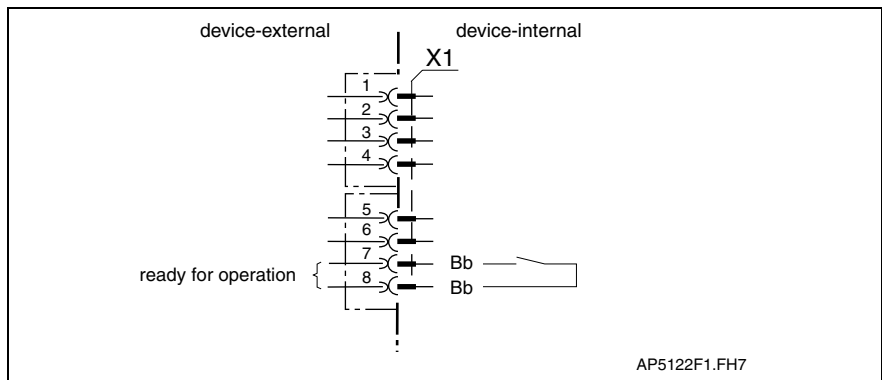

Fig. 6-16: Connections for ready to operate contact

Loadability of the connection Bb:

max. Switching voltage:	DC 40 V
max. Switching current:	DC 1 A
max. continuous current:	DC 1 A
Minimum contact load:	10 mA
Guaranteed number of switching operations at max. time constant of load < 50 ms:	250.000

Switching states Bb:

The Bb contact is open if:

- the control voltage for the BZM01.3 has not been applied or
- if there is an error in the BZM01.3

How to use the contact, see page 11-2: "Control Circuits for the Mains Connection".



WARNING

Damage possible if Bb contact not connected!

The Bb contact acknowledges auxiliary bleeder readiness to the application of power.

⇒ Integrating the Bb contact of the BZM01.3 as per "Control Circuits for Connect the Mains".

X2, DC bus dynamic brake (ZKS), Diagnostic Signals

Technical description of connector

Illustration:

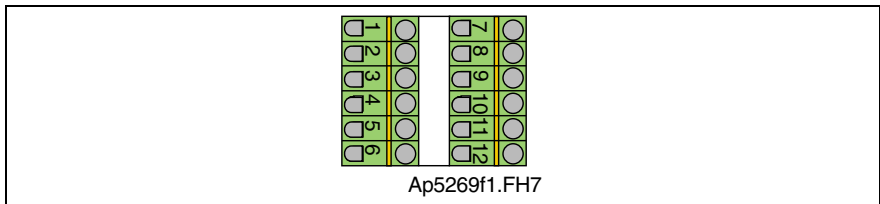

Fig. 6-17: Connector X2

Design:

Type	No. of pins	Design
spring contact	2 x 4	bushing on connector

Fig. 6-18: Design

Connection cross section:

Cross section single wire [mm ²]	Cross section multi core wire [mm ²]	Cross section in AWG gauge no.:
0.2-2.5	0.2-1.5	24-16

Fig. 6-19: Connection cross section X2

ZKS control supply

Connection
+24V pro and 0V:

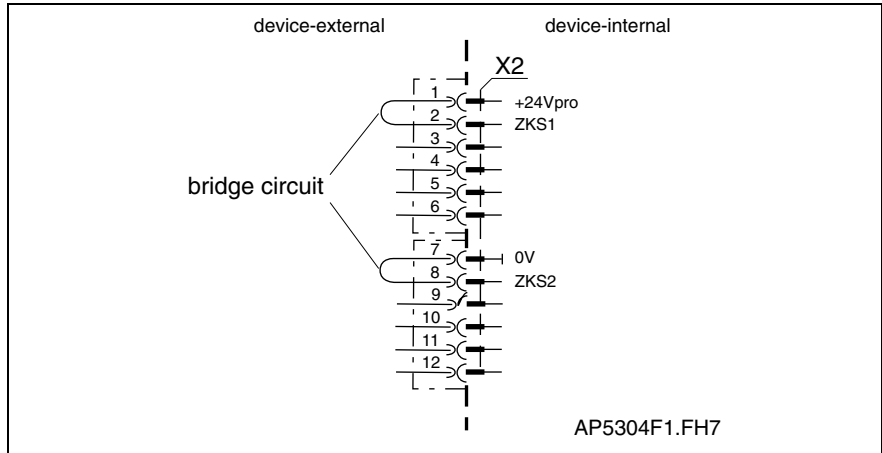
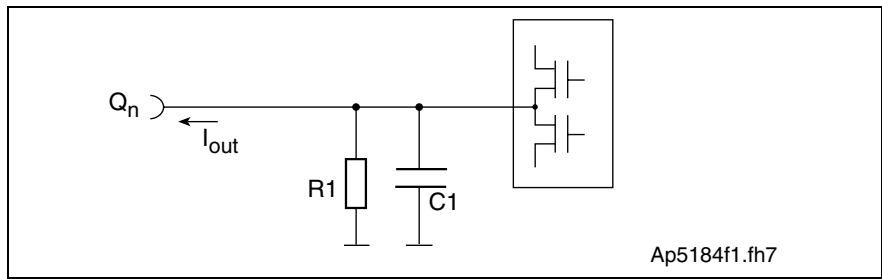

Fig. 6-20: Connection +24V pro, 0V

At delivery with bridges at: X2.1 to X2.2
X2.7 to X2.8

Output
+24V pro:



R1: approximately 50 R
C1: 100 μF
Fig. 6-21: Voltage source from X2.1

Loadability of the connection
+24Vpro:

max. output voltage (dependent of control voltage at X1.1)	voltage at X1.1 – 2V
max. allowed output current:	DC 0.1 A
max. allowed lead length	10 m
thermal overload protection	via charging current limiter behind X1.1
max. short circuit current	2.4 A

Application
+24V pro:

The connections supply current to the ZKS input.

ZKS control input

Connection
ZKS1 and ZKS2:

See page 6-13 "Fig. 6-20: Connection +24V pro, 0V".

Input circuit
ZKS1 and ZKS2:

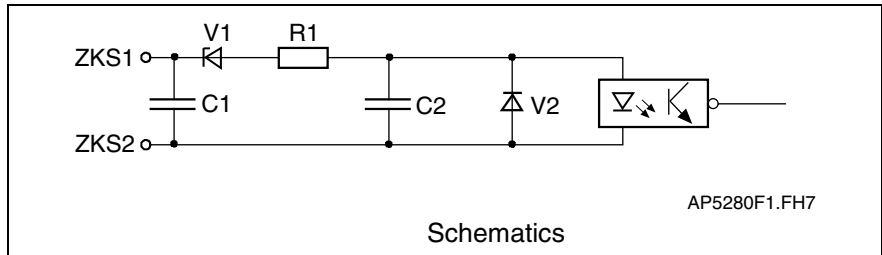

- R1: 2k2
- V1: 10V
- V2: 0.7V
- C1: 0.1µF
- C2: 0.1µF

Fig. 6-22: Input circuit

Inputs
ZKS1 and ZKS2:

Input voltage:	min.	max.
High	17.6 V	28.8 V
Low	0 V	5 V
trigger delay t_d due to contactor drop delay	min.	max.
	40 ms	80 ms
input resistance	about 2 kOhm \pm 5%	
potential isolation	to 50 Veff	
Polarity reversal protection within allowed input voltage range		

Fig. 6-23: Inputs

Use
ZKS1 and ZKS2:

The connections supply the ZKS input and permit potential free control of DC bus dynamic brake setup via a relay contact.

Trigger behavior of DC bus setup:

Mains voltage at X5	DC input	DC bus setup
not applied	no current	active
not applied	current	not active
applied	not current	not active
applied	current	not active

Fig. 6-24: Trigger behavior of ZKS setup

Protecting the ZKS setup with mains voltage applied:

Note: If mains voltage applied at X5 then DC bus dynamic brake not executed! The ZKS control is realized with the currentless input.

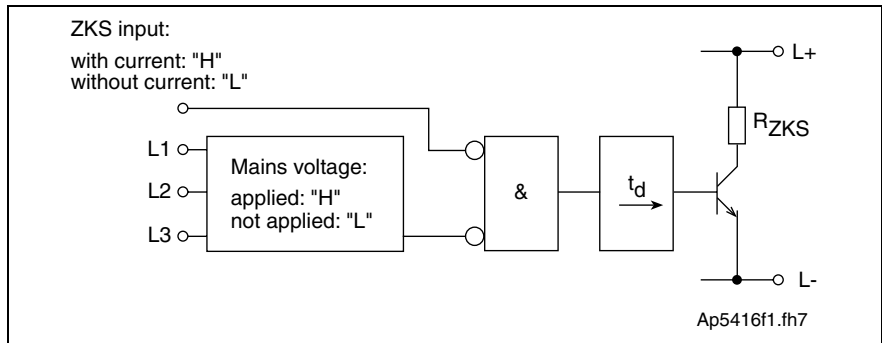

Fig. 6-25: Block diagram interlock ZKS/Mains

Also see page 4-25: "Arranging the Central supply" and page 11-5: "Control Circuits with internal DC bus dynamic brake (ZKS)".

Analog Output Load:

Connection:

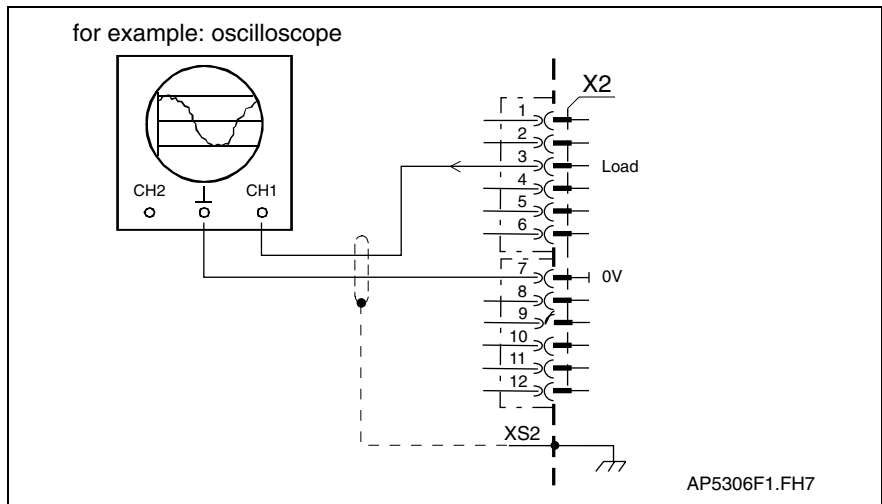
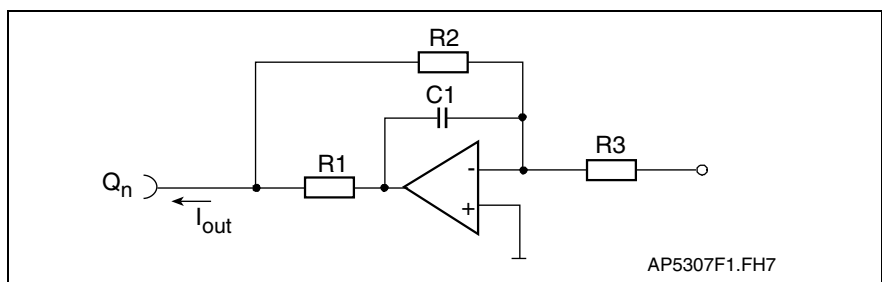

Fig. 6-26: Output load

Output circuit Load:



- R1: 150R
- R2: 20k
- R3: 10k
- C1: no data

Fig. 6-27: Output circuit

Output Load:	Output voltage between load and 0 V:	min 0 V	max. 10 V
	output current	Max. 2 mA	
	DA converter	no data	
	resolution per bit	no data	
	short circuit and overload protection	not present	
	evaluation	$\frac{U}{10V} \cdot P_{BD,BZM}$	

Fig. 6-28: Output load

Load: The connection is used to output an analog signal of the proportional load of the mounted bleeder resistor.

Ready, Warning:

Connection Ready, Warning:

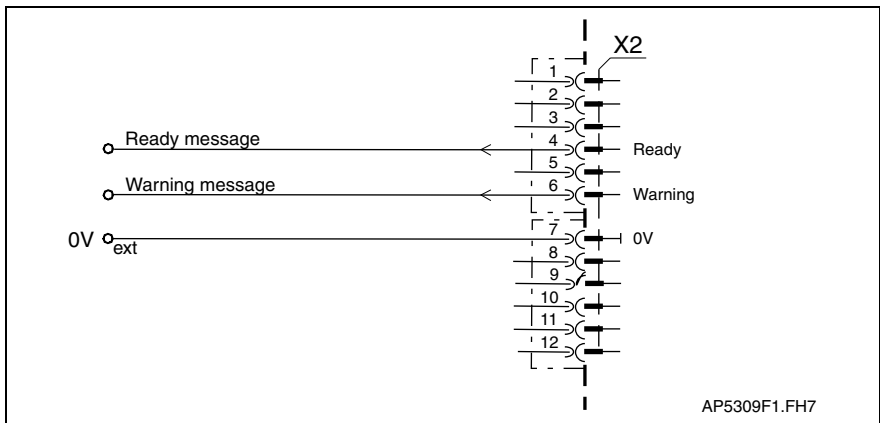
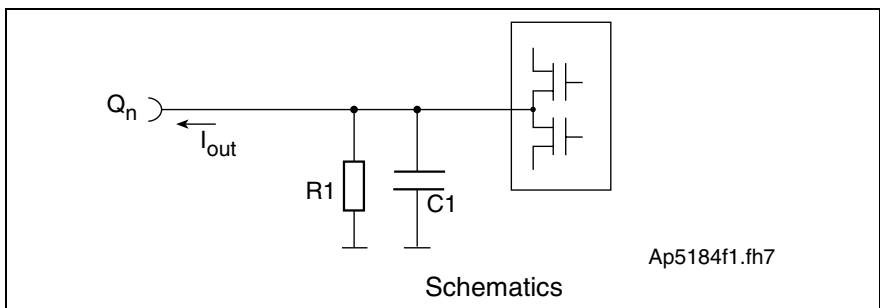

Fig. 6-29: Output Ready, Warning

Output circuit Ready, Warning:



R1: 20k
C1: 1nF

Fig. 6-30: Output circuit

Outputs Ready, Warning:

Output voltage:	min.	max.
High	16 V	U_ext (an X1.1-1V)
Low	-0.5 V	1.5 V
Output current I _{out}	80 mA	
Rise and drop time	about < 600 ns	
Overload protection	<ul style="list-style-type: none"> - short circuit protection at I_{out} > 300 mA outputs switch off - thermal shutdown 	

Fig. 6-31: Outputs Ready, Warning

- Warning message:** The signal is set to "High"
- if pre-warning signal threshold for maximum bleeder load exceeded (internally permanently set)
 - or if pre-warning signal threshold is exceeded for maximum bleeder temperature (internally permanently set).

Further operations up to the shutdown threshold is possible but this causes the Bb contact to open.

- Ready:** Output set to "low"
- if error is pending
 - if control voltage failed

Clear error

The clear error input supports the resetting of the unit's internal error memory.

Connection clear error:

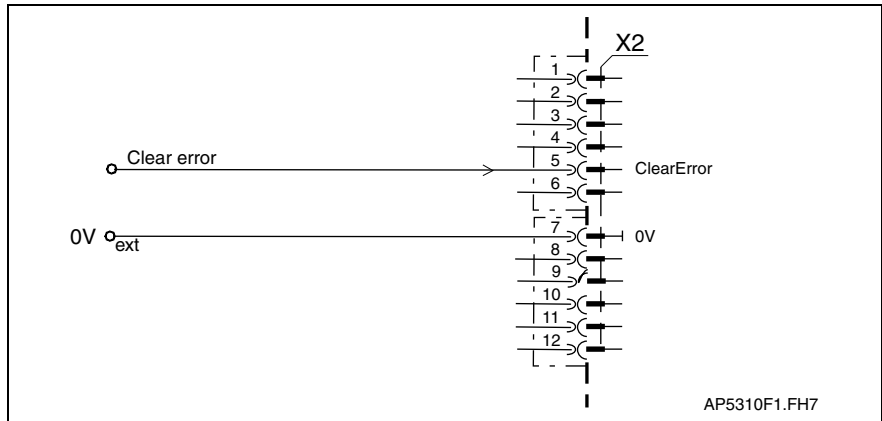
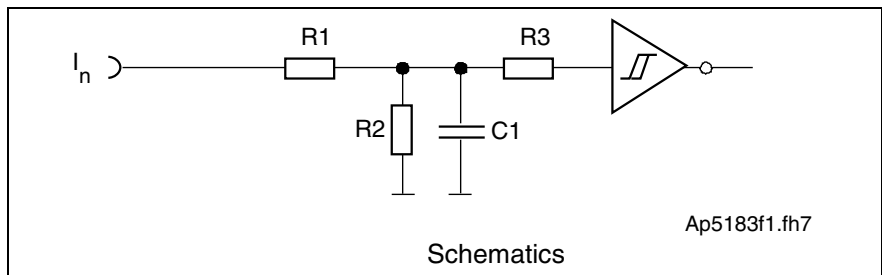

Fig. 6-32: Input clear error

Input circuit Clear error:



- R1: 10k
- R2: 3k3
- R3: 10k
- C1: 10nF

Fig. 6-33: Input circuit

Inputs Clear error:

Input voltage:	min.	max.
High	16 V	30 V
Low	-0.5 V	3 V
Input resistance	about 13.3 kOhm	

Fig. 6-34: Inputs

Clear error: Giving a positive edge at input the "Clear error", the entire error memory is deleted.

X3, RS 232 Interface

Note: For internal use only.

X5, DC bus and Mains connection

Technical description of connector

Illustration:

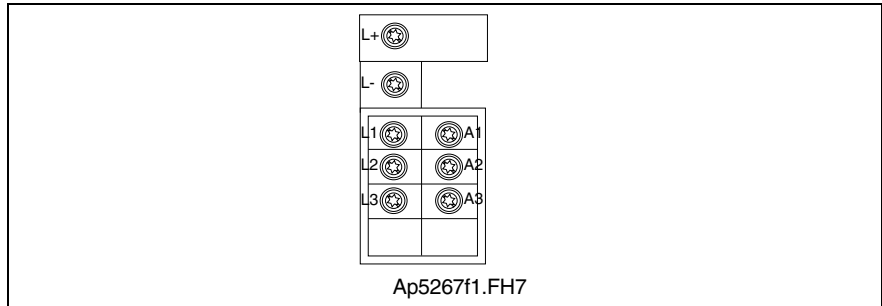

Fig. 6-35: Connector X5

Design:

Type	No. of pins	Design
Connection block	2 / 3 / 3	Screw connection for ring terminal M5

Fig. 6-36: Design

Tightening torque:

min. tightening torque [Nm]	max. tightening torque [Nm]
2.5	3.0

Fig. 6-37: Tightening torque

Connection cross section:

Cross section single wire [mm ²]	Cross section multi core wire [mm ²]	Max. Cross section in AWG gauge no.:
--	25	--

Fig. 6-38: Connection cross section

DC bus connection

Connection
DC bus:

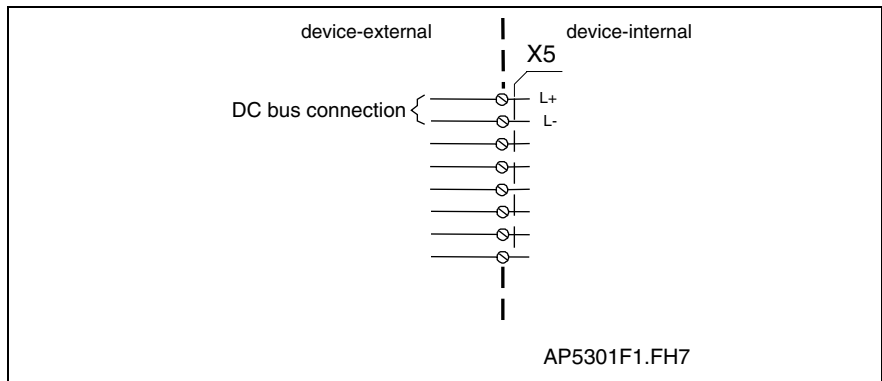

Fig. 6-39: Connection DC bus



CAUTION

Damage possible if DC bus connections L+ and L- are reversed!

⇒ Make sure polarity is correct.

wire
DC bus

If the DC bus rails supplied do not make a connection possible, then use short twisted wires to do so.

wire length:	max. 2 x 1 m
wire cross section:	min. 10 mm ² , not smaller than the cross section of the mains supply lead
wire protection	With a fuse in the mains connections
Voltage resistance of individual wires to ground	≥ 750 V (e.g., litz wires - H07)

Motor connection

Motor connection:

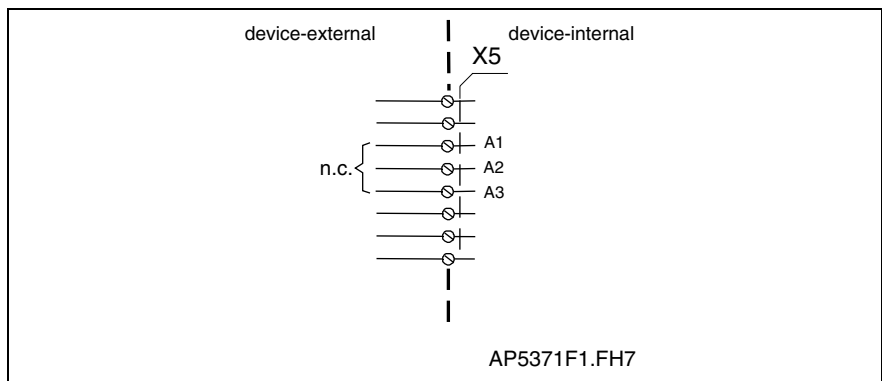

Fig. 6-40: Motor connection

Note: Connections A1, A2, A3 are not wired!

Mains connections

The mains connector serves as the connection of the drive controller with the power supply.

Single-phase mains connection:

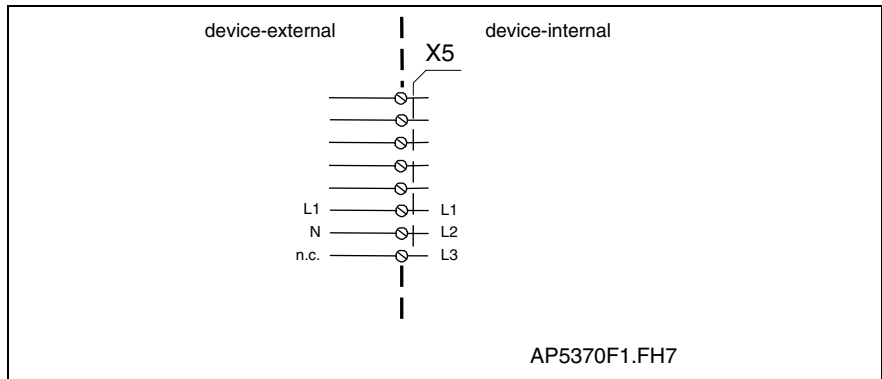

Fig. 6-41: Single-phase mains connection

Three-phase mains connection:

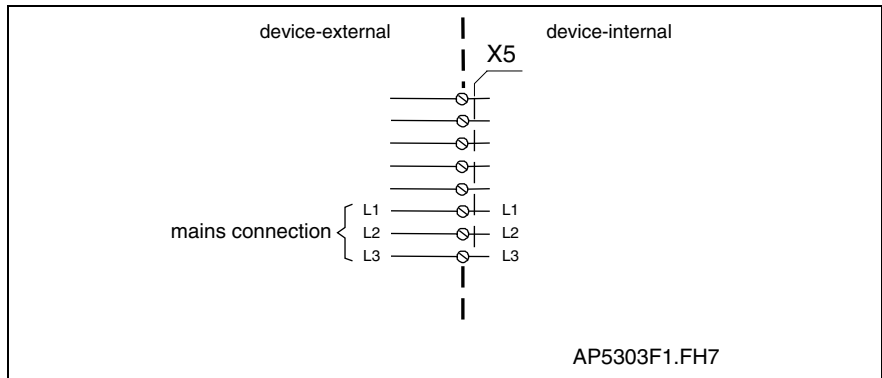

Fig. 6-42: Three-phase mains connection

Note: Mains connections should not be daisy-chained between the units (intermediate connectors for the supply source should be used).

See page 11-1: "Mains Connections"

XE1, Protective conductor connection for mains

Technical description of connector

Illustration: See "Fig. 6-8: Front view Auxiliary Bleeder Module BZM01.3" on page 6-7.

Design:	Type	No. of pins	Design
	screw	1	screw for ring terminals M5

Fig. 6-43: Version

Tightening torque:	min. tightening torque [Nm]	max. tightening torque [Nm]
	2.5	3.0

Fig. 6-44: Tightening torque

Connection cross section:	Cross section single wire [mm ²]	Cross section multi core wire [mm ²]	Max. cross section in AWG gauge no.:
	--	25	--

Fig. 6-45: Connection cross section

XE1, Protective conductor connection for mains

Note: PE connection $\geq 10 \text{ mm}^2$
Reason: high leakage currents (EN 50178/1998,
section: 5.3.2.1)

XS1, XS2, Shield connections

XS1 and XS2

Further shield connections.

Diagnostic LEDs and Reset Probe

Diagnostic LED (green) H1:

State	Definition
blinking LED	applied control voltage is ok and DC bus voltage $U_{ZW} \leq 50 \text{ V}$
continuous light	and DC bus voltage $U_{ZW} > 50 \text{ V}$

Fig. 6-46: Diagnostic LED (green) H1

Diagnostic LED (red) H2:

State	Definition
blinking LED	$W_{BZM} > 90\% * W_{MAX, BZM}$ OR $P_{BZM} > 90\% * P_{BD, BZM}$ OR Temperature pre-warning (internal heatsink)
continuous light	overload, overtemperature, internal error

Fig. 6-47: Diagnostic LED (red) H2

Reset probe S1: Reset the H2 diagnostic LED once overload or overtemperature problems have been cleared.

Notes

7 ECODRIVE03 Auxiliary Capacitance Module CZM01.3

7.1 General

The auxiliary capacitance module is advantageous in the following situations:

- reducing power loss within the control cabinet
- storing energy in drive applications with short cycle times
- increasing allowed continuous power in the DC bus of DKC controllers

7.2 Technical data

Dimensions

Dimension sheets auxiliary capacitance module CZM01.3

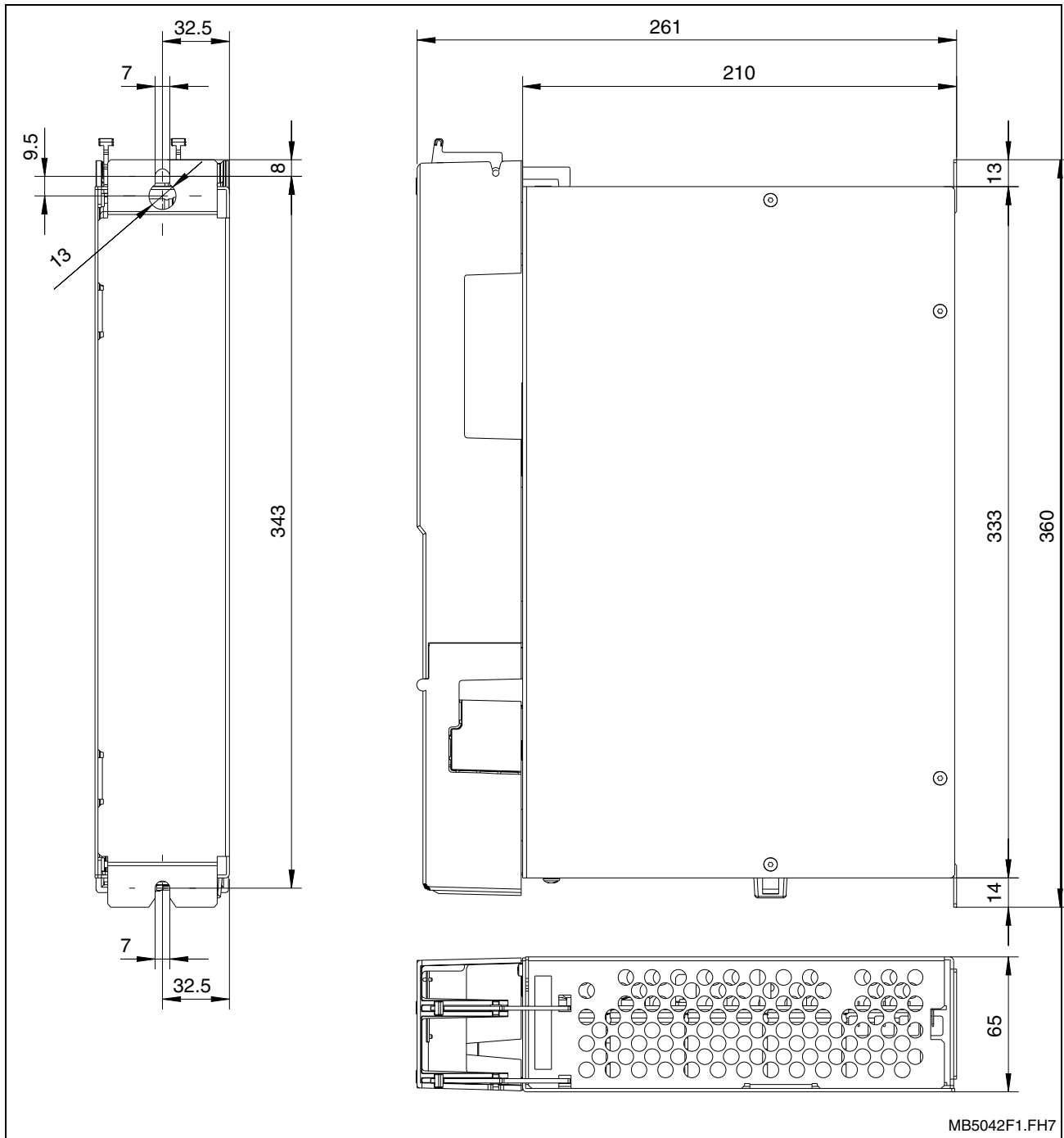

Fig. 7-1: Dimensions of the auxiliary capacitance module CZM01.3

Also see page 12-1: "Constructing the Control Cabinet"

Materials used, Mass

Designation	Symbol	Unit	CZM01.3
Mass	m	kg	5
Materials used	-	-	asbestos and silicone free

Fig. 7-2: Materials used, Mass

Ambient and operating conditions

See page 4-4: "Ambient and operating conditions"

Electrical Data of Auxiliary Component CZM01.3

Power section

Designation	Symbol	Unit	CZM01.3
nominal DC bus capacity	C_{ZW}	mF	2.4
Nom. discharge time constant	τ	s	43
Storable energy of the DC bus capacitors	$W_{ZW,CZM}$	Ws	See "Fig. 7-4: Storable energy in the DC bus for CZM01.3"
Allowed input voltage at L+, L- at X5	U_{ZW}	V	DC bus voltage ECODRIVE DC (300 ... 800)
Device power dissipation	P_V	W	50
Mains input voltage	U_N	V	n.c.
Cooling			natural convection
Insulation resistance at DC500V	R_{is}	MOhm	> 25

Fig. 7-3: Technical data CZM01.3

See also page 16-4 CZM01.3

Note: The higher the connection voltage the lower the energy that can be stored in the DC bus as the differential voltage between bleeder threshold and DC bus voltage (threshold value of connecting voltage) decreases.

Storable energy

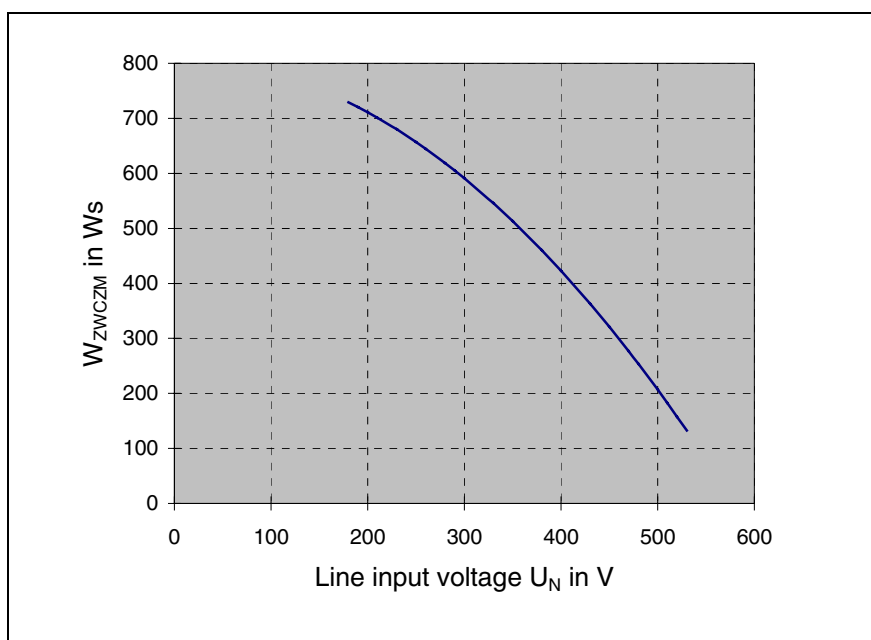

Fig. 7-4: Storable energy in the DC bus for CZM01.3

CE Label, Tests

CE label

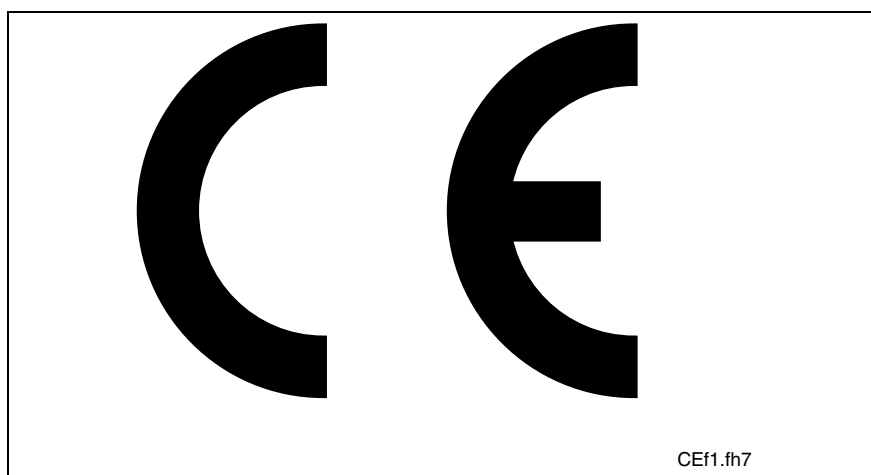

Fig. 7-5: CE label

Tests:

High-voltage test according to EN50178	Routine test with DC2100V	1 s
Insulation test according to EN50178	Routine test with DC500	1 s
Separation between the electrical circuits of the control and high voltage power	safe separation according to EN50178	
Clearances and creepage distances	according to EN50178	

Fig. 7-6: Tests

7.3 Electrical Connections of CZM01.3

Front View

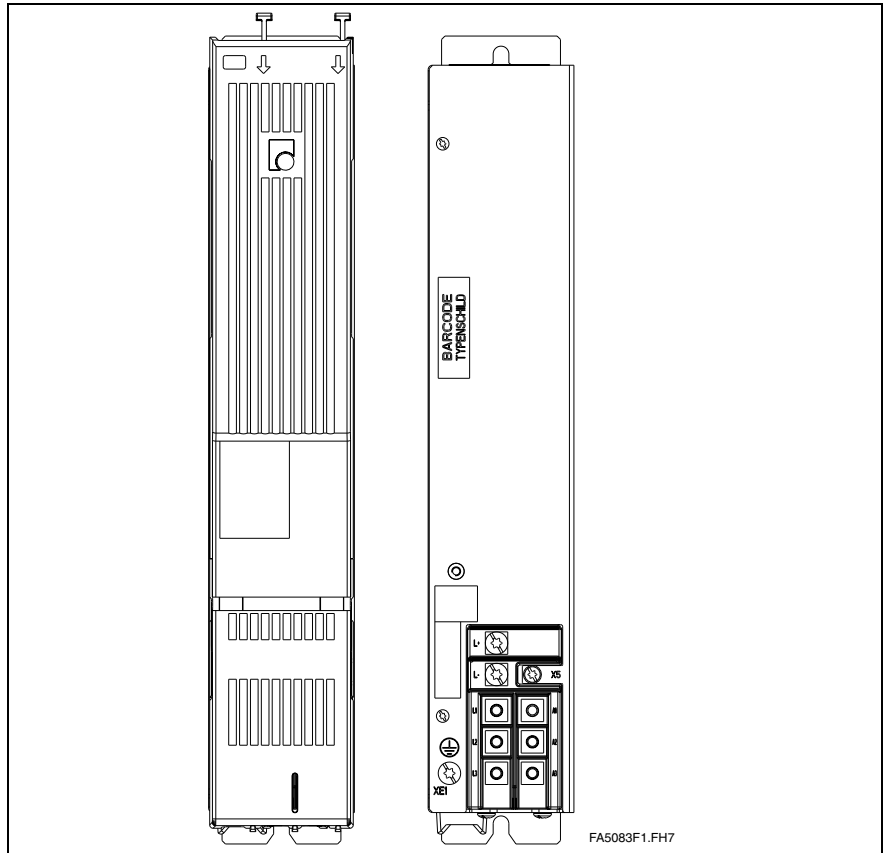

Fig. 7-7: Front view of auxiliary capacitance module CZM01.3

X5, DC bus connection

Technical description of connector

Illustration:

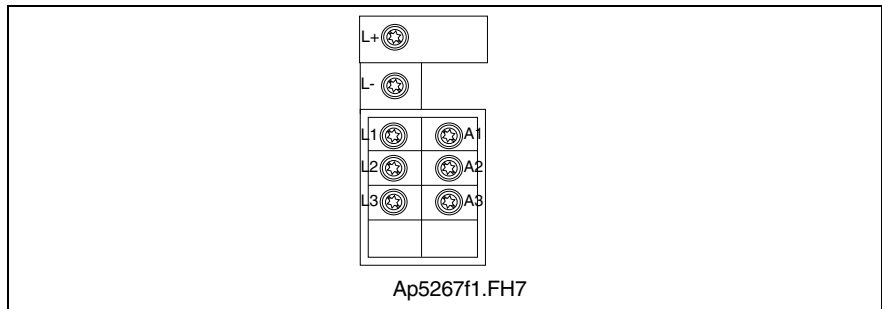

Fig. 7-8: Connector X5

Design:

Type	No. of pins	Design
Terminal block	2 / 3 / 3	Screw for ring terminals M5

Fig. 7-9: Design

Tightening torque:

min. tightening torque [Nm]	max. tightening torque [Nm]
2.5	3.0

Fig. 7-10: Tightening torque

Connection cross section:

Cross section single wire [mm ²]	Cross section multi core wire [mm ²]	Cross section in AWG gauge no.:
--	25	--

Fig. 7-11: Connection cross section

Connection:

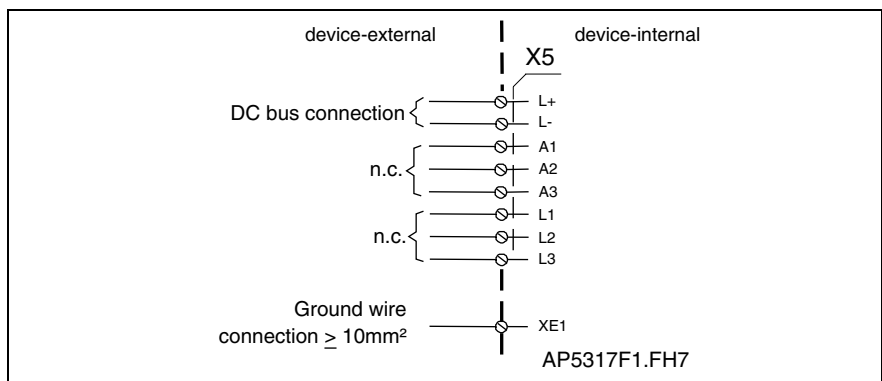

Fig. 7-12: DC bus connection of auxiliary capacitance module CZM01.3 – X5

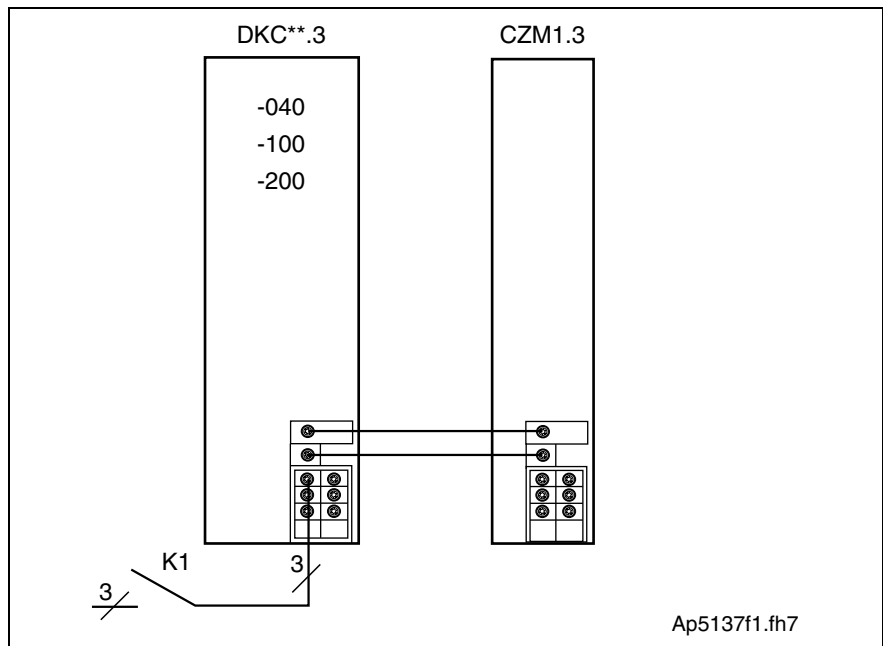

Fig. 7-13: Connection of auxiliary capacitance module CZM01.3



CAUTION

Damage possible if DC bus connections L+ and L- are reversed!

⇒ Make sure polarity is correct.

Wire DC bus: If the DC bus rails supplied do not make a connection possible, then use short twisted wires to do so.

wire length:	max. 2 x 1 m
wire cross section:	min. 10 mm ² , not smaller than the cross section of the mains supply lead
wire protection	with a fuse in the mains connections
voltage resistance of individual wires to ground	≥ 750V (e.g., litz wires - H07)

XE1, Protective conductor connection for mains

Technical description of connector

Illustration: See page 7-5: "Front View".

Design:	Type	No. of pins	Design
	screw	1	Screw for ring terminals M5

Fig. 7-14: Design

Tightening torque:	min. tightening torque [Nm]	max. tightening torque [Nm]
	2.5	3.0

Fig. 7-15: Tightening torque

Connection cross section:	Cross section single wire [mm ²]	Cross section multi core wire [mm ²]	Max. Cross section in AWG gauge no.:
	--	25	--

Fig. 7-16: Connection cross section

Note: PE connection $\geq 10 \text{ mm}^2$
Reason: high leakage currents (EN 50178/1998, section: 5.3.2.1)

8 Choke GLD 12

8.1 General

The use of choke GLD 12 increases the allowed DC bus continuous power.

8.2 Dimensions and Mounting Dimensions

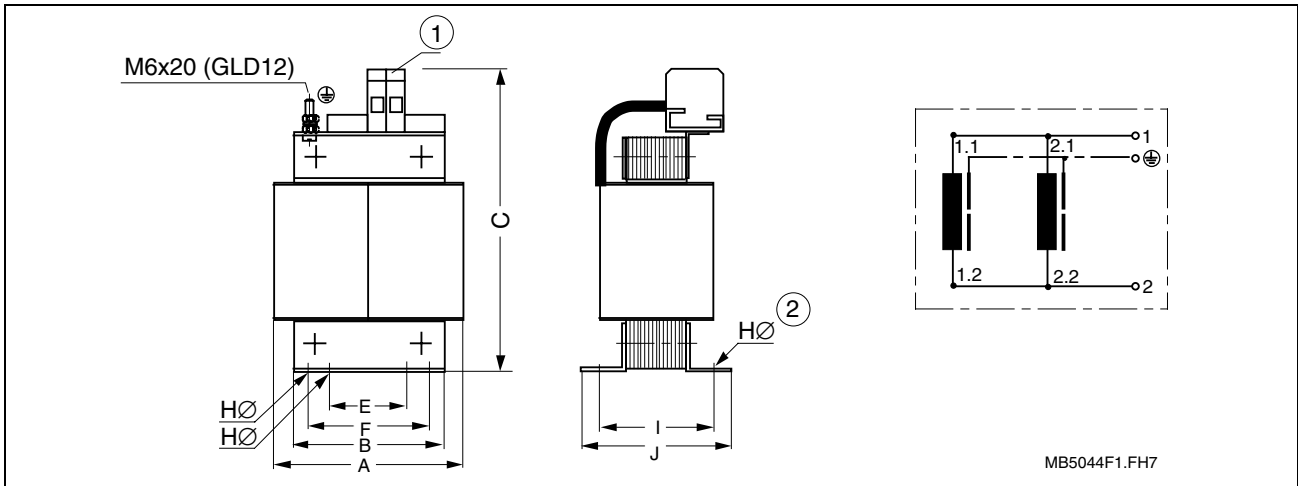

1: Electrical connection
 2: Slot in "J" direction
 Fig. 8-1: Dimensions GLD 12

Type	mH/A	Maße in mm								Maximum connection cross section	Mass kg	Power dissipation W
		A	B	C	E	F	HØ	I	J			
GLD12	1.0/100	160	121	285	60	100	7x14	97	121	35 mm ²	13.5	100

Fig. 8-2: Technical data for GLD 12

Connection GLD 12: see page 4-93: "X12, Optional Choke Connection for DKC**.3-200-7"

Notes

9 DC24V NTM power supplies

9.1 Application recommendations

If there is no external DC24V control voltage available, then Rexroth Indramat recommends the use of NTM power supply units.

- Features**
- The power supplies contain an overvoltage safety switch with automatic shutdown. After the automatic shutdown device has responded, operation can be resumed by switching the power supply off, briefly, and on again.
 - The power supplies always function with a starting current limiter. However, if you switch off and on again within a period of 10 s, the starting current limit do not work!
 - The NTM01.1-024-004 and NTM01.1-024-006 power supplies make it possible to measure the voltage applied to the load via cable sensor. If there is a voltage drop, the power supply will increase the output voltage accordingly.
 - Installation in enclosed control cabinet required.

Fuse protector Q2 Rexroth Indramat recommends a 10 A automatic circuit breaker with tripping characteristics C for DC24V NTM power supplies.

Line filter

Note: Mains filters are available to comply with EMC-limits. For a selection of information see project planning manual "Electromagnetic Compatibility (EMC) in Drive and Control Systems", doc.-type DOK-GENERL-EMV*****-PRxx.

9.2 Technical data

Designation	Symbol	Unit	NTM01.1-24-002	NTM01.1-24-004	NTM01.1-24-006
Output rated voltage	U_{out}	VDC	24	24	24
Adjustment range		%	+/-10	+/-10	+/-10
Rate current of the 24V output for 45 °C ambient temperature	I_N	A	2.1	3.8	5.5
Output power for 45 °C ambient temperature	P_{OUT}	VA	50	100	150
input current at 230 (115) V	I_{IN}	A	0.61 (1.2)	1.2 (2.2)	1.9 (3.2)
inrush current for 230 (115) V at the power input line when the NTM is switched on. Size the back-up fusing accordingly	I_{EIN}	A	32 (16)	32 (16)	32 (16)
Input voltage	U_N	V	Standard AC 170...265 by changing the bridge circuit setting AC 85...132		
Degree of protection	installation in enclosed control cabinet required				

Fig. 9-1: Technical data for DC24V NTM power supply units

9.3 Dimensional sheets and installation dimensions

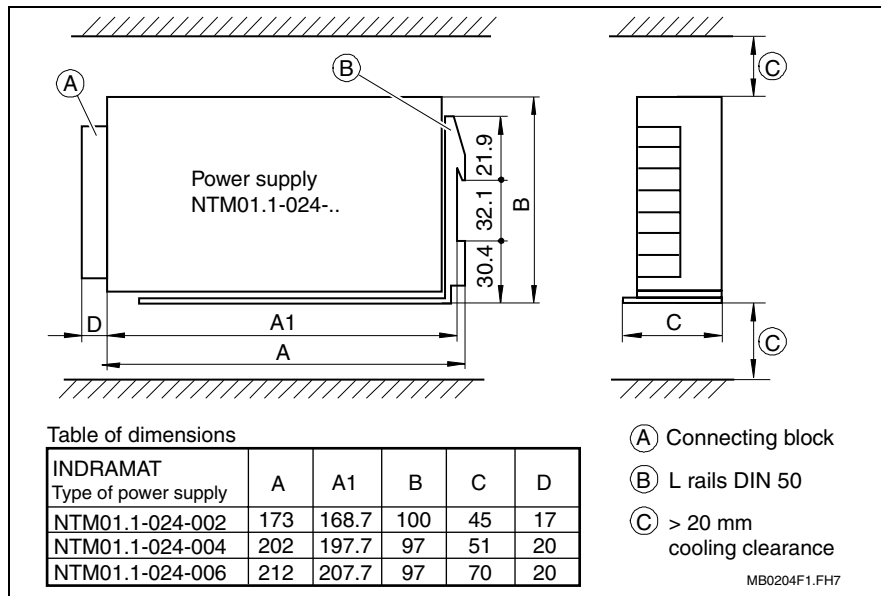

Fig. 9-2: Dimensional sheet DC24V – NTM power supplies

9.4 Front views

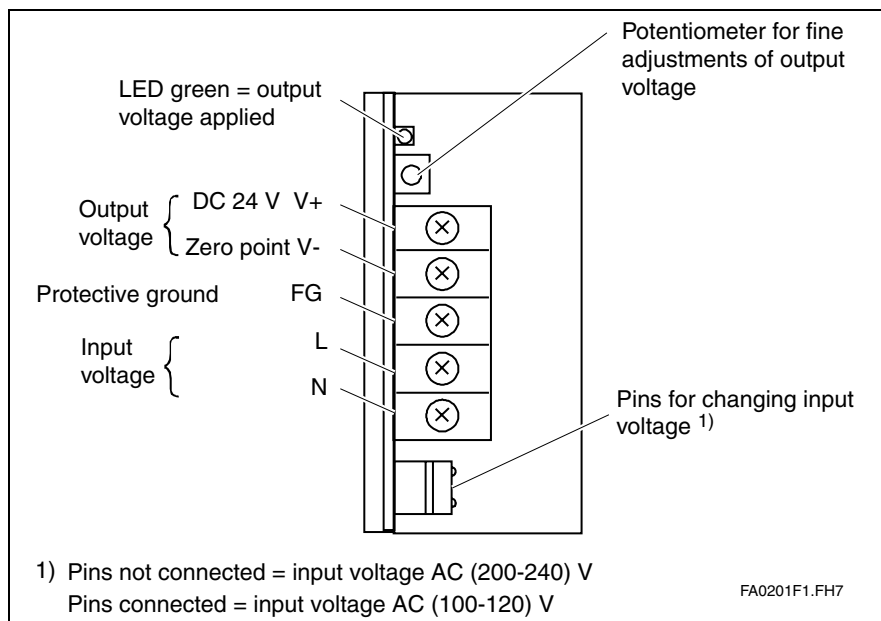

Fig. 9-3: Front view and terminal designations of the power supply NTM01.1-024-002

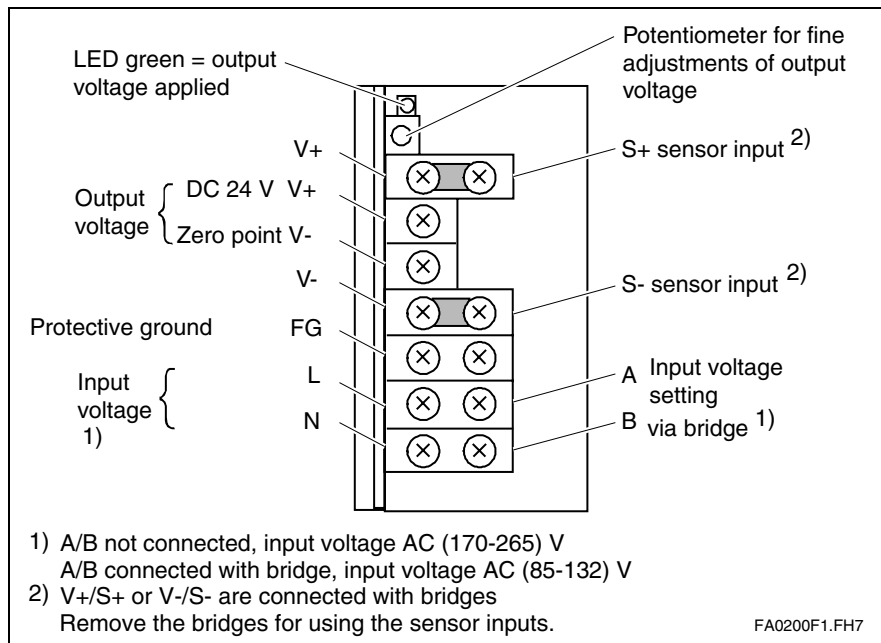

Fig. 9-4: Front view and terminal designation of the power supplies NTM01.1-024-004 and NTM01.1-024-006

9.5 Electrical connection

Note: Always use the NTM together with the line filter NFE01.1-250-006. For further information on NFE, see project planning manual "Electromagnetic Compatibility (EMC) in Drive and Control Systems", doc.-type DOK-GENERL-EMV*****-PRxx.

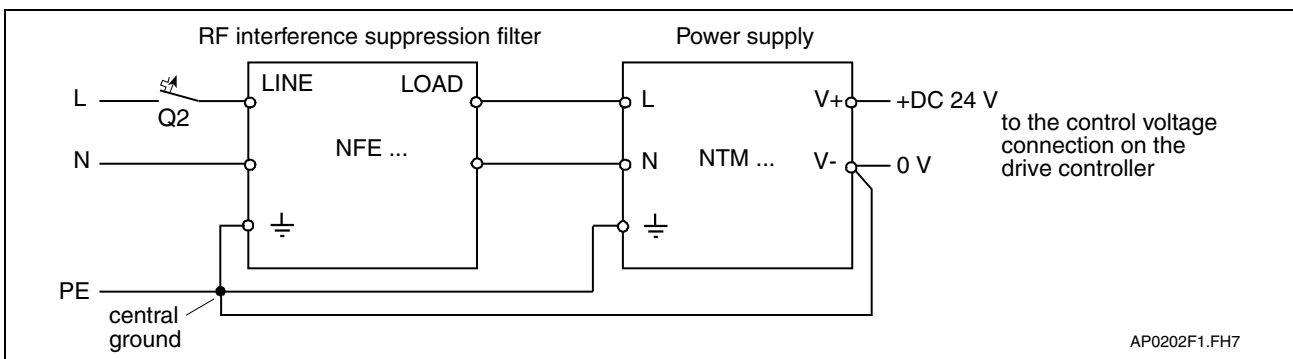

Fig. 9-5: Connecting the power supply to a line filter

Note: The contact bridge between V+/S+ and V-/S- must be removed if sensor inputs are used.

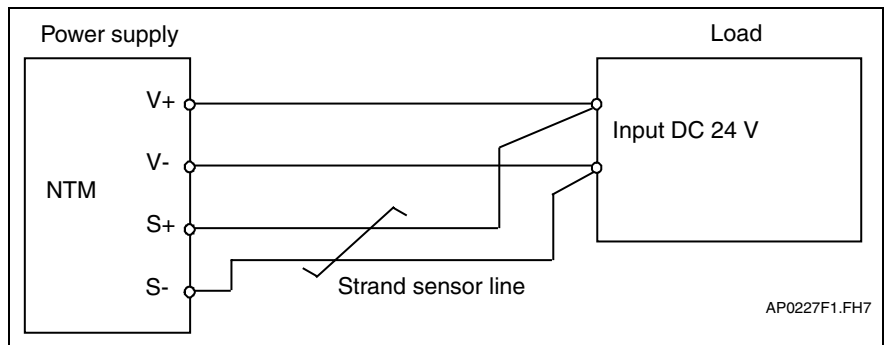

Fig. 9-6: Connecting the sensor cables NTM01.1-024-004 and NTM01.1-024-006

9.6 Type code

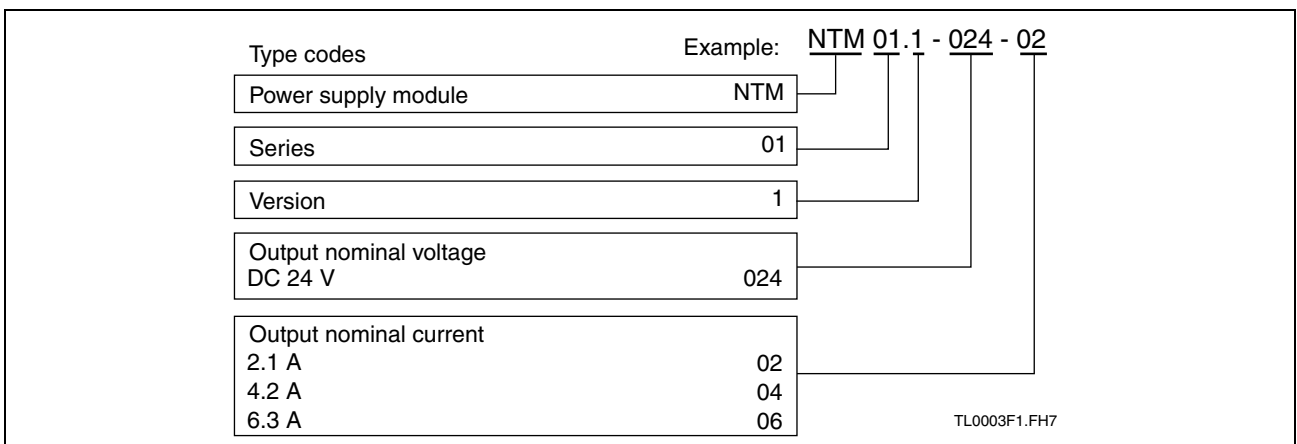

Fig. 9-7: Type code

10 DST transformers

10.1 Selection

Transformers are only needed if the systems voltage exceeds the rated voltage of the drive controller.

Grounded power supply lines For grounded power supply lines, the line voltage is matched to the rated voltage of the units using autotransformers which are suited to **one specific output voltage range**.

Ungrounded power supply lines To match the voltage for ungrounded power supply lines, always connect isolating transformers to prevent excess phase to ground voltages.

10.2 Autotransformers for Drive Controllers

Select an autotransformer suited to both the line voltage and the power requirements of the system.

Proceed with the selection as follows:

- ⇒ Determine the rating group using the required rated line voltage range in the diagram "Classification of the three-phase alternating current autotransformers and then locate the transformer ratio "i".
- ⇒ Calculate the actual transformer output voltage using the rated line voltage and the transformation ratio "i".
- ⇒ Check the drive data. The output voltage of the transformer has an effect on the drive data.
- ⇒ Select a three-phase autotransformer corresponding to the required connected load.

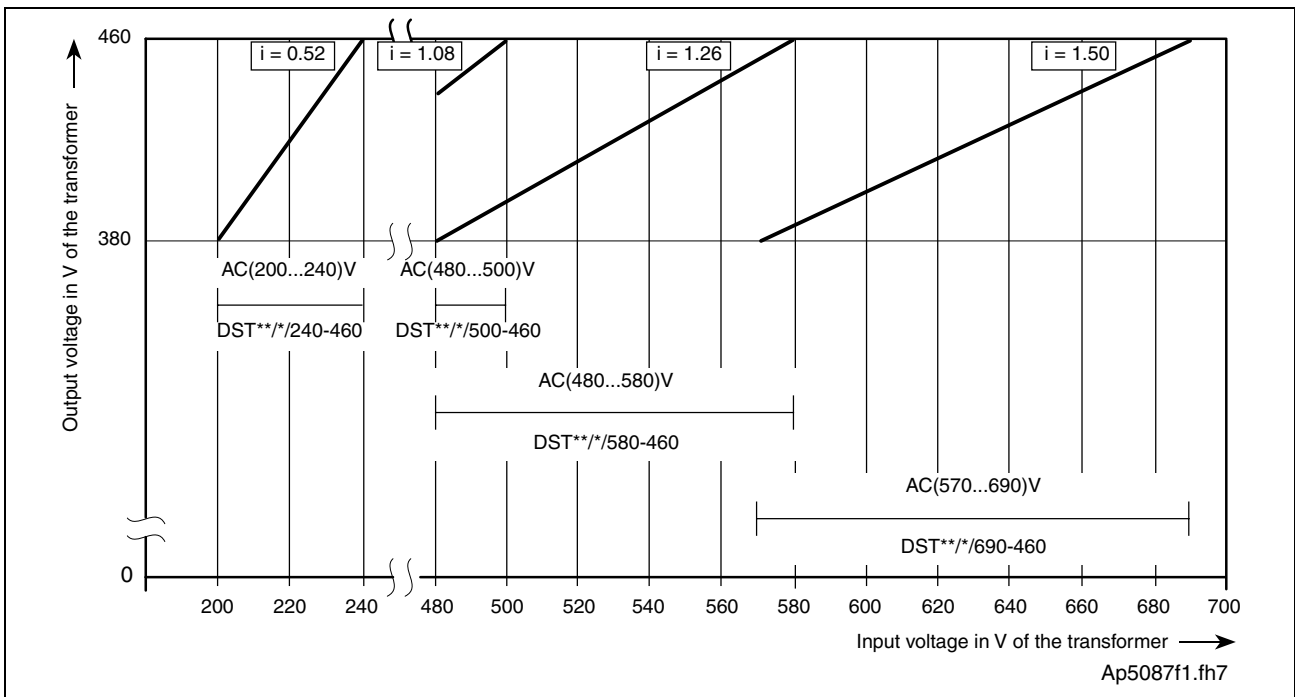
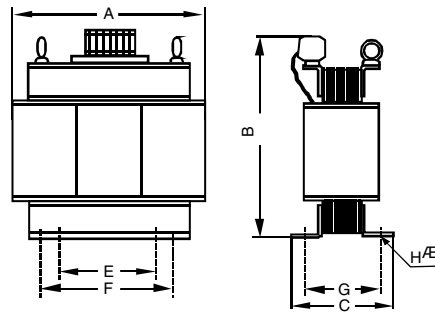

Fig. 10-1: Classification of three-phase autotransformers in rating groups

DST autotransformer with secondary or output voltage AC (380 to 460) V

Standing version for mounting with base: DST..../S



Rating plate (example)

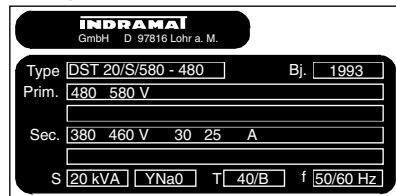

Block diagram

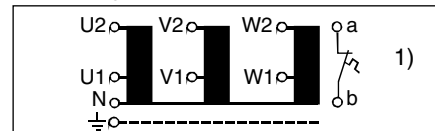

1) Temperature switch max. load:
DC 24V/1A; AC 230V/1A

Type designation DST...	Conn. output in KVA	Trans- mission ratio	Dimensions in mm							Power loss in W	max. cross section in mm ²	Weight in kg
			A	C	B	F	E	G	H \varnothing			
Input voltage: AC (200...240) V \pm 10%												
4/S/240-460	4		240	150	260	170	110	120	11	120	10	24.5
7,5/S/240-460	7.5		335	175	365	230	160	145	11	225	10	55
12,5/S/240-460	12.5	0.52	360	190	395	250	170	160	11	310	10	70
25/S/240-460	25		480	195	500	356	-----	158	13	500	35	135
50/S/240-460	50		580	265	540	400	270	215	18	750	70	195
Input voltage: AC (480...500) V \pm 10%												
4/S/500-460	4		180	105	190	125	80	75	7	160	4	8.5
7,5/S/500-460	7.5		205	130	210	145	95	95	7	260	4	13
12,5/S/500-460	12.5	1.08	240	140	260	170	110	110	11	440	10	22
25/S/500-460	25		300	155	325	210	140	125	11	750	16	36
50/S/500-460	50		335	175	365	230	160	145	11	1050	35	53
Input voltage: AC (480...580) V \pm 10%												
4/S/580-460	4		240	130	260	170	110	100	11	140	4	18
7,5/S/580-460	7.5		240	140	260	170	110	110	11	260	4	22
12,5/S/580-460	12.5	1.26	300	155	325	210	140	125	11	375	10	37
25/S/580-460	25		360	190	395	250	170	160	11	625	10	72
50/S/580-460	50		420	215	450	280	190	155	14	1000	35	95
Input voltage: AC (570...690) V \pm 10%												
4/S/690-460	4		240	140	260	170	110	110	11	140	10	22
7,5/S/690-460	7.5		300	155	325	210	140	125	11	225	10	37
12,5/S/690-460	12.5	1.5	335	175	365	230	160	145	11	375	10	57
25/S/690-460	25		420	205	450	280	190	145	14	500	16	88
50/S/690-460	50		480	222	500	356	-----	185	13	750	35	178

MB5007f1.fh7

Fig. 10-2: DST autotransformers for drive controllers to match the line voltage

10.3 Type code

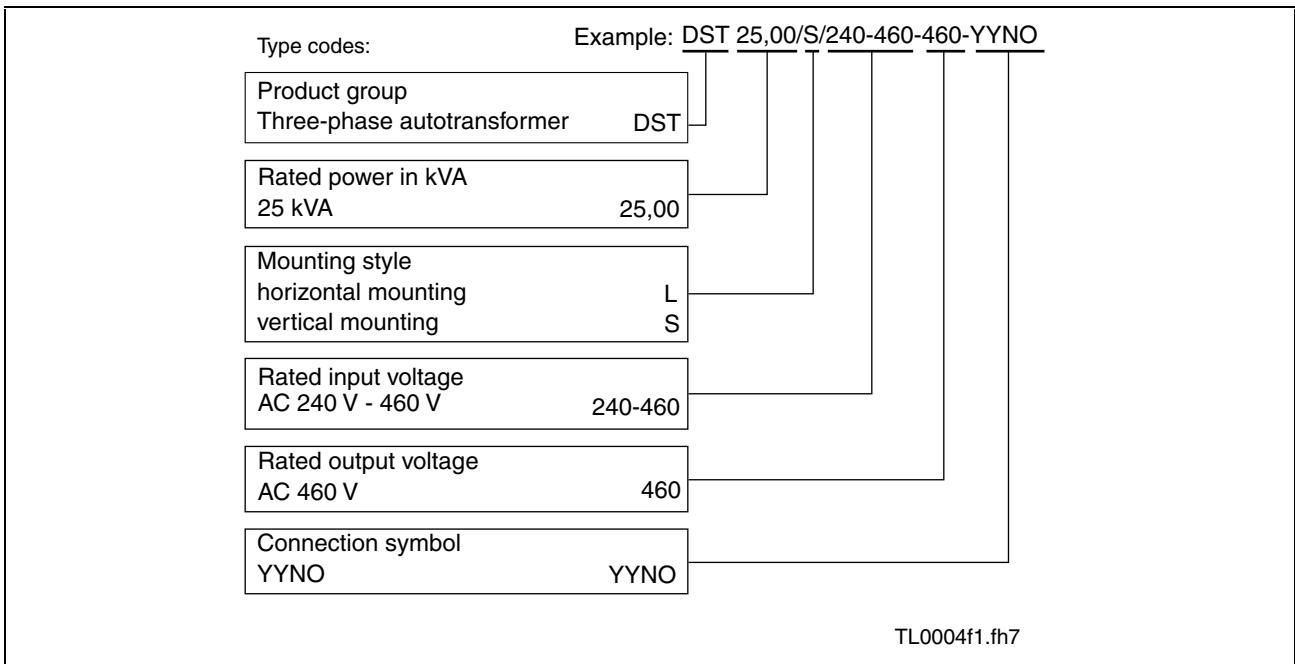

Fig. 10-3: Type code

11 Mains Connections

11.1 General

Note: An ECODRIVE03 drive controller must be permanently connected to the power supply network.

Connection DKC**.3-040/100/200-7-FW: see page 4-62 X5, DC bus, Motor and Mains Connections.
DKC**.3-016-7-FW: see page 5-32 X5, Motor and Mains Connections.

Line filter

Note: Mains filters are available to comply with EMC-limits. For a selection of information see project planning manual "Electromagnetic Compatibility (EMC) in Drive and Control Systems", doc.-type DOK-GENERL-EMV*****-PRxx.

11.2 The Ground Conditions of the Power Supply Network

Grounded three-phase current networks

Drive controllers of the ECODRIVE03 family can be operated on three-phase current networks with grounded star point or external conductors without potential isolation.

Ungrounded three-phase networks

Ungrounded networks (IT networks) present the increased danger of unallowable phase to ground overvoltages occurring. Drive controllers of the ECODRIVE03 family can be protected against overvoltages

- By connecting them via an isolating transformer (the star point of the output side and the PE connection of the power supply unit are linked on a shared ground rail)

- or -

- If the facility is protected via an overvoltage suppressor.

Connecting ECODRIVE03 drive controllers via an isolating transformer offers the best protection against overvoltage as well as the greatest operating safety.

Overvoltage

The periodic overvoltage of ECODRIVE03 drive controllers between phase (L1, L2, L3) and ground may not exceed 1000 V (threshold value). Transient overvoltage (< 50 μ s) may, as per EN61800-3/1996, equal a max value of 1000 V phase to phase and 2000 V phase to ground.

Note: If higher overvoltages occur, then they must be limited with the use of overvoltage suppressors in the cabinet or building.

Note: Mains voltages exceeding the specified range require the use of a step-down transformer.

11.3 Earth-leakage circuit breaker

It is not possible to use a earth-leakage circuit breaker in ECODRIVE03 drive controllers (EN 50178/1994, section: 5.3.2.3).

Protection against indirect contact is implemented by the protective grounded housing of the components of the drive system.

11.4 Control Circuits for the Mains Connection

The control circuits recommended by Rexroth Indramat specify the functional principle.

Note: The choice of control and its effects depends on the extent of the functions and the operating sequence of facility or machine. It is therefore the responsibility of the manufacturer of the installation and machine.

Signal contact Bb ready to operate

The ready to operate message is output via a relay contact (N/O). If the Bb contact closes, then the drive is ready to receive power. The contact is thus a precondition for connecting the mains contactor.



Danger of damage !

⇒ The effectiveness of the separation of, the mains connection via signal contact "Ready to operate Bb" or the multi-circuits of all ECODRIVE Bb contacts must be ensured !

Switching states

See also page 4-48: "Ready to operate contact Bb" resp. page 5-22 for DKC**.3-016.

⇒ See also firmware functional description: "Power shutdown with fault"

Note: When the mains contactor is shut off the mains coil causes overvoltages. These can cause the Bb contact to drop prematurely. To attenuate overvoltage use overvoltage limiters with diode combinations.

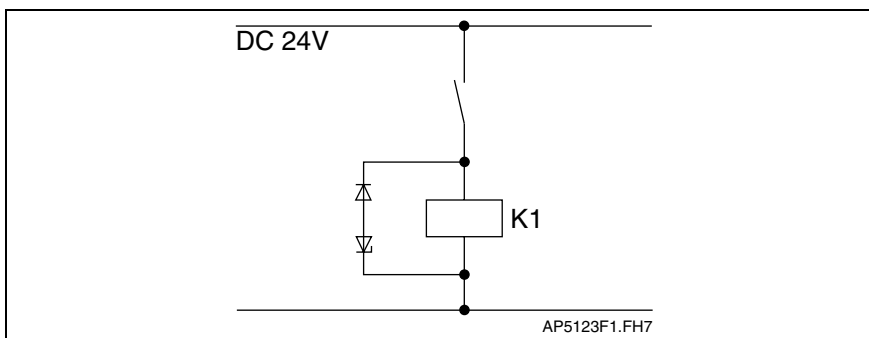

Fig. 11-1: Recommended protective circuits

The use of varistors and RC modules as protective circuits is not allowed. Varistors age and increase their locking currents. RC modules make excessive demands of the switching capabilities of the Bb contact. This leads to early failures of connected components and units.

Note: Load limits of the Bb contacts must be maintained. Contactors with AC excitation or those that exceed the load limits of the effected contact elements (Bb contacts, etc.) can be controlled with the use of auxiliary contactors.



CAUTION

Damages!

⇒ Before switching the device on again, wait at least 300 ms plus the fall-delay time of the mains contactor (see page 11-12).

Control Circuits with E-Stop

Pre-requisite:

The E-stop input is available if the E-stop function has been activated in the software (see firmware functional description).

Use the E-stop function if drive-internal error reactions must be activated as quickly as possible as a result of the following events:

- The emergency off button is pressed.
- Power is shut down.
- Error message from control (lag error monitor, emergency off actuated by the control).

If the E-stop function is not used, then the drive-internal error reaction is not triggered until the K1 contactor opens and, as a result, "undervoltage in DC bus" is detected in the controller.

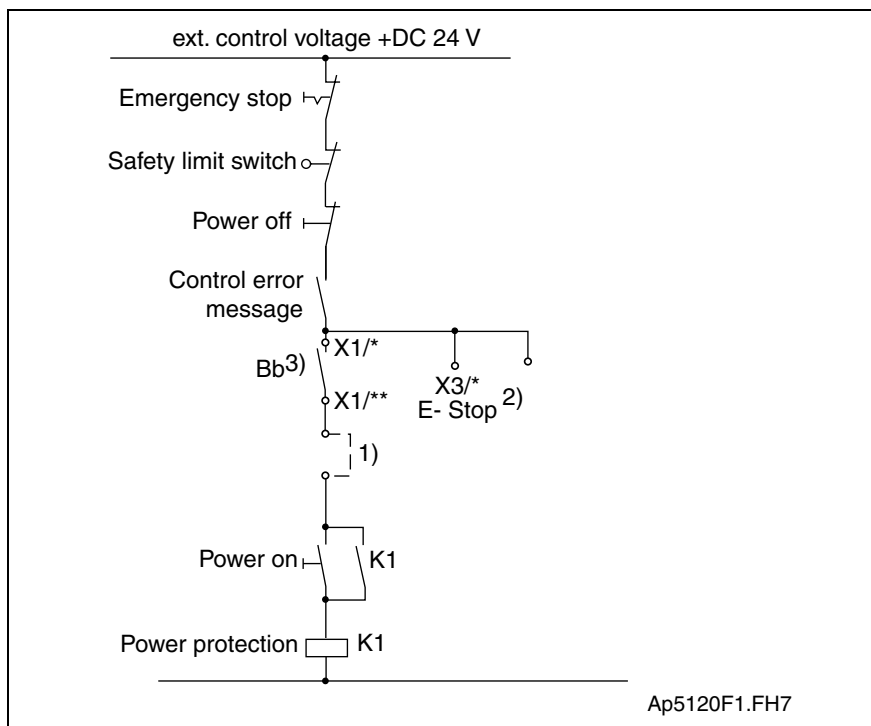

- 1): Integrating Bb contacts of more drive controllers and BZM**.* in series connection.
 (Bb contact: DKC**.3-040/100/200-7-FW: X1/* = X1/7; X1/** = X1/8;
 DKC**.3-016-7-FW: X1/* = X1/4; X1/** = X1/6)
- 2): E-stop for more drive controllers on same contactor.
 (Bb contact: DKC**.3-040/100/200-7-FW: X3/* = X3/6;
 DKC**.3-016-7-FW: X3/* = X3/7)
- 3): Switching power of Bb contact must be noted.
- Fig. 11-2: Example of generating the E-stop signal

Note: Do not pick off the E-Stop signal after the Bb contact.

If the safety end switches illustrated also function as a travel range limit, then a separate set-up must be created in case of actuation, which makes it possible to move back out of the end position!

=> See also firmware functional description: "Travel range limits".

Control Circuits with internal DC bus dynamic brake (ZKS)

The internal DC bus dynamic brake is used:

- To brake energized permanent-magnet servo motors, if a controlled braking with the drive controller is not possible as a result of a unit fault.
- For a quick discharge of the DC bus.

Note: DKC**.3-016-7-FWs and DKC**.3-040-7-FWs have no internal ZKS setup.

The ZKS connection have bridges installed at delivery, thus deactivating the ZKS function.

=> See page 4-62: "X5, DC bus, Motor and Mains Connections".



The ZKS does not guarantee personnel safety!

- ⇒ A DC bus dynamic brake will bring synchronous motors to a standstill regardless of whether the drive electronics are still working or not.
 - ⇒ Without this, synchronous motors run uncontrolled if the drive control electronics are faulty.
 - ⇒ Asynchronous motors do not brake if the DC bus voltage is short circuited!
-

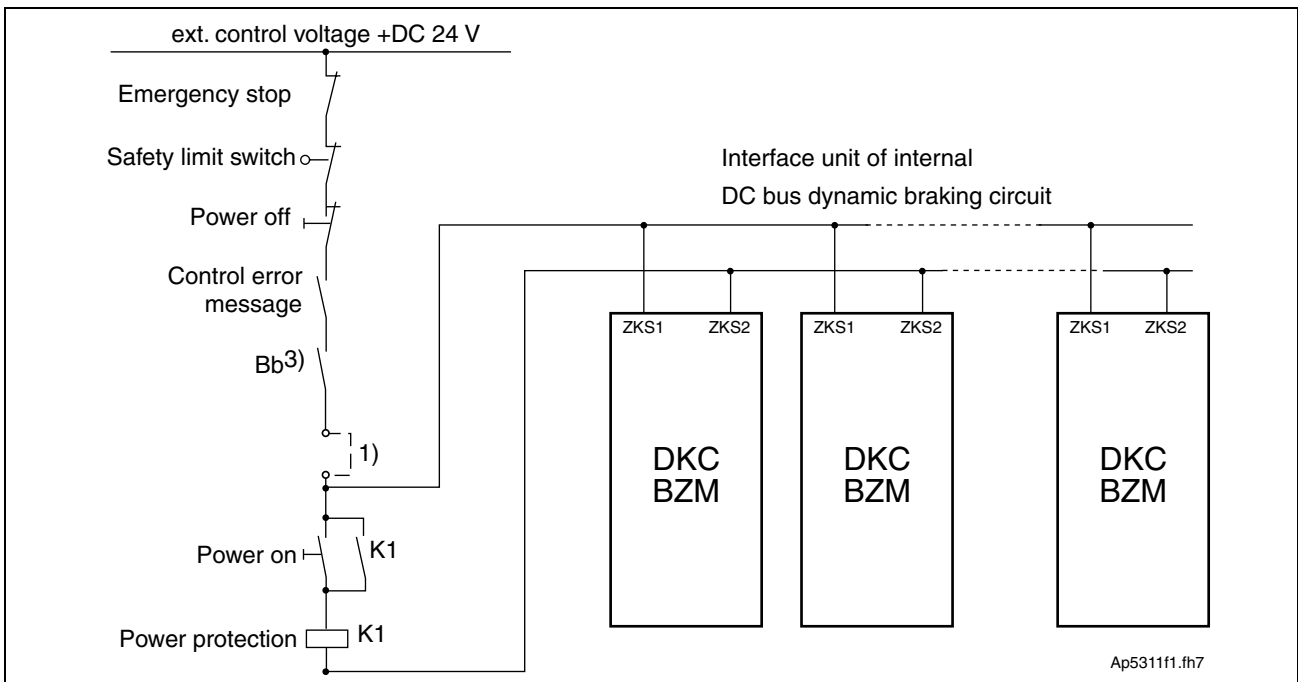

1): Integrate Bb contacts of more drive controllers and BZM**.* in series.
 3): Switching power of Bb contact must be noted.
 Fig. 11-3: Example of generating the DC ZKS signal

Note: All ZKS setups are controlled parallel on shared DC bus loop!
 Any delay in the drop out of the main contactor also causes a delay in the activation of the ZKS function.
 => See page 11-12: "Q1 Fuse and K1 Contactor".



Danger of damage!

=> If as a result of the application a manual actuation of the load contactor K1 is necessary then the built in DC bus dynamic brake setups must be protected by applying switched mains voltage to the mains connecting terminals of the DKC and BZM units in use.

11.5 Mains Contactor / Fuses

To select suitable mains contactor and fuses for the power connection, a selection table is available. Note the inrush current of the selected contactor.

Computing phase current on the mains

To select a suitable mains contactor and fuses for the power connections it is necessary to first compute the phase current I_N at the mains.

The mains-side phase current I_N is determined out of the mains connecting power S_{AN} .

Select the mains connecting power in the list or compute it according to the following formula. With multiple controllers, add the individual powers.

$$P_{ZWD} = \frac{M_{EFF} \cdot n_{MITTEL} \cdot 2 \cdot \pi \cdot k}{60}$$

- P_{ZWD} : required DC bus continuous power in W
 - M_{EFF} : rms torque in Nm
 - n_{MITTEL} : mean speed in min-1
 - k : factor for motor and controller efficiency = 1.25 (MKD, MHD)
- Fig. 11-4: Computing DC bus power

$$S_{N1} = P_{ZWD} \cdot F$$

- S_{N1} : connected load in VA
 - P_{ZWD} : DC bus continuous power in W
 - F : connected load factor
 - F=2.8 for single-phase feed
 - F for three-phase feed see page 11-9:
 - "Factor F for Computing the Connected Load"
- Fig. 11-5: Computing mains connected load

Single-phase load:	$I_{N1} = \frac{S_{N1}}{U_{N1}}$
Three-phase load:	$I_{N1} = \frac{S_{N1}}{U_{N1} \cdot \sqrt{3}}$

- I_{N1} : mains-side phase current in A
 - S_{N1} : connected load in VA
 - U_{N1} : voltage between phases of the mains in V
- Fig. 11-6: Computing mains-side phase current

Computing charging current inrush

$$I_{\text{Ein}} = \frac{U_{\text{N1}} * \sqrt{2}}{R_{\text{Softstart}}}$$
$$\sum I_{\text{Ein}} = I_{\text{EinGesamt}}$$

I_{Ein} : charging current inrush of unit in A
 $I_{\text{EinGesamt}}$: total charging current inrush in A (value relevant for fusing)
 U_{N1} : mains input voltage
 $R_{\text{Softstart}}$: softstart resistance of unit (see relevant technical data)

Fig. 11-7: Computing charging current inrush

Note: To compute the charging current inrush take all the units connected to the mains voltage into account.

Factor F for Computing the Connected Load

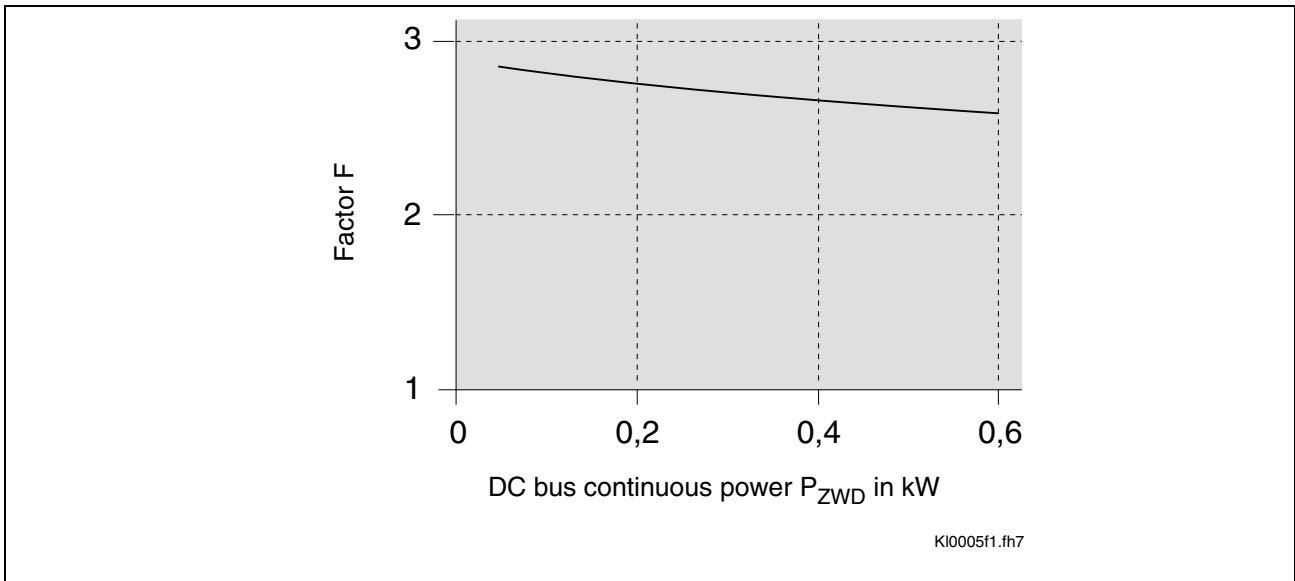

Fig. 11-8: Connected load factor for DKC**.3-016-7 (for 3*AC (200 ... 480) V)

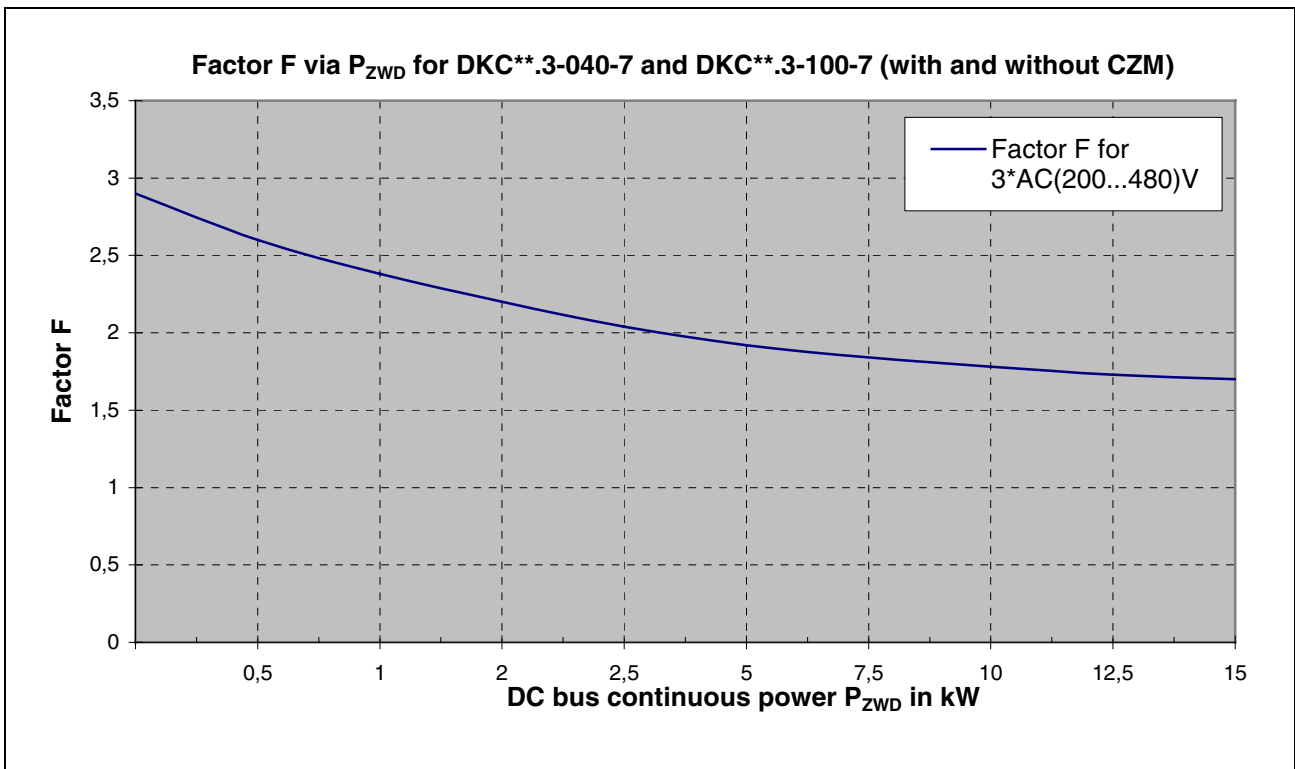

Fig. 11-9: Connected load factor for DKC**.3-040-7 and DKC**.3-100-7

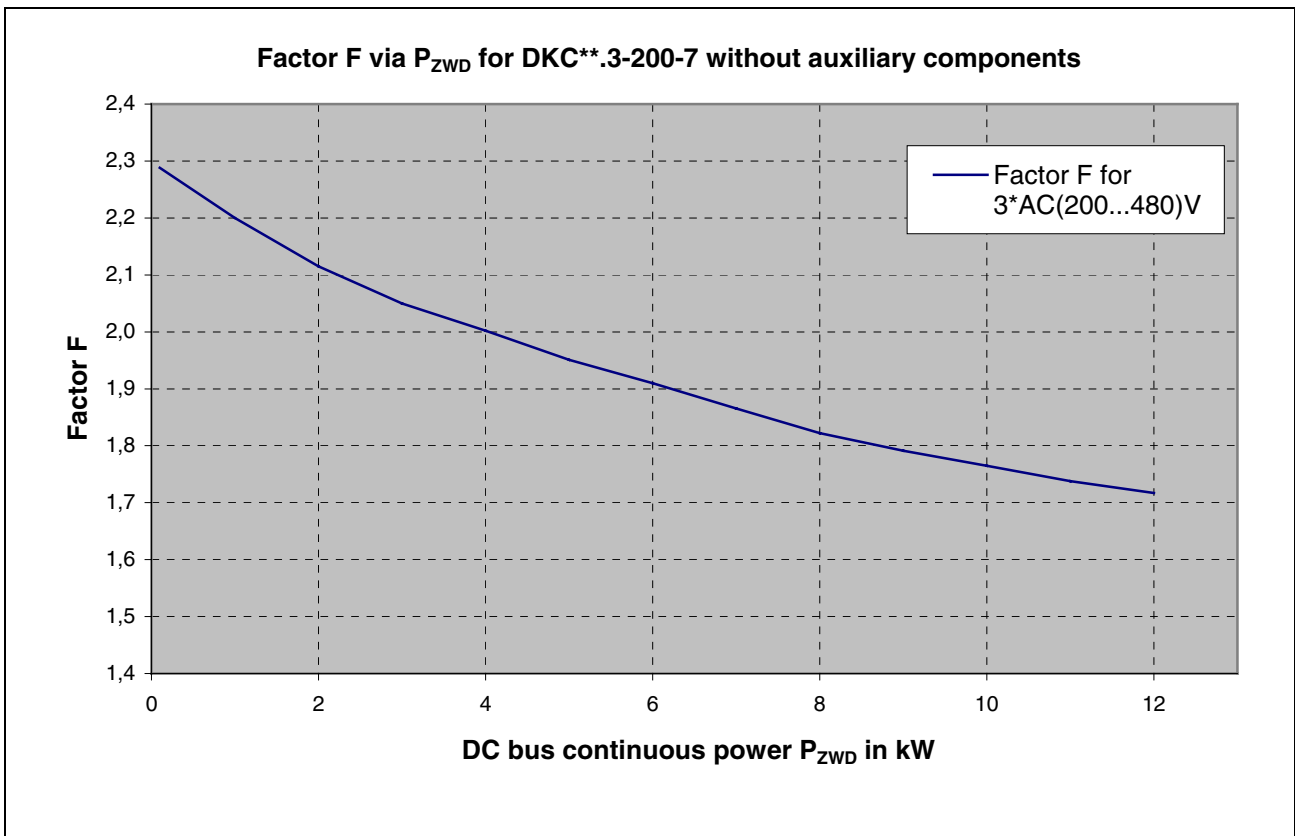

Fig. 11-10: Connected load factor for DKC**.3-200-7

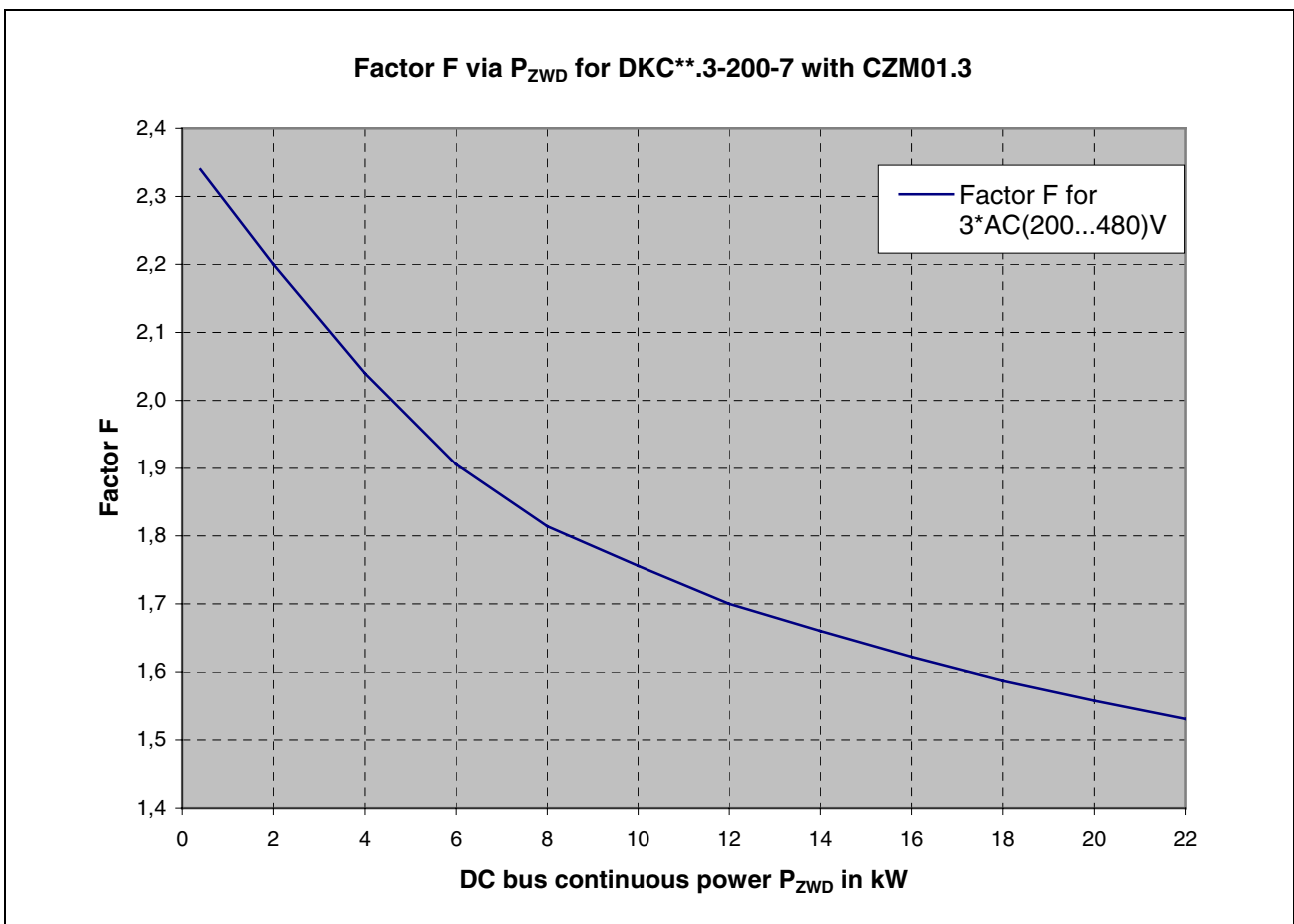

Fig. 11-11: Connected load factor for DKC**.3-200-7 with CZM01.3

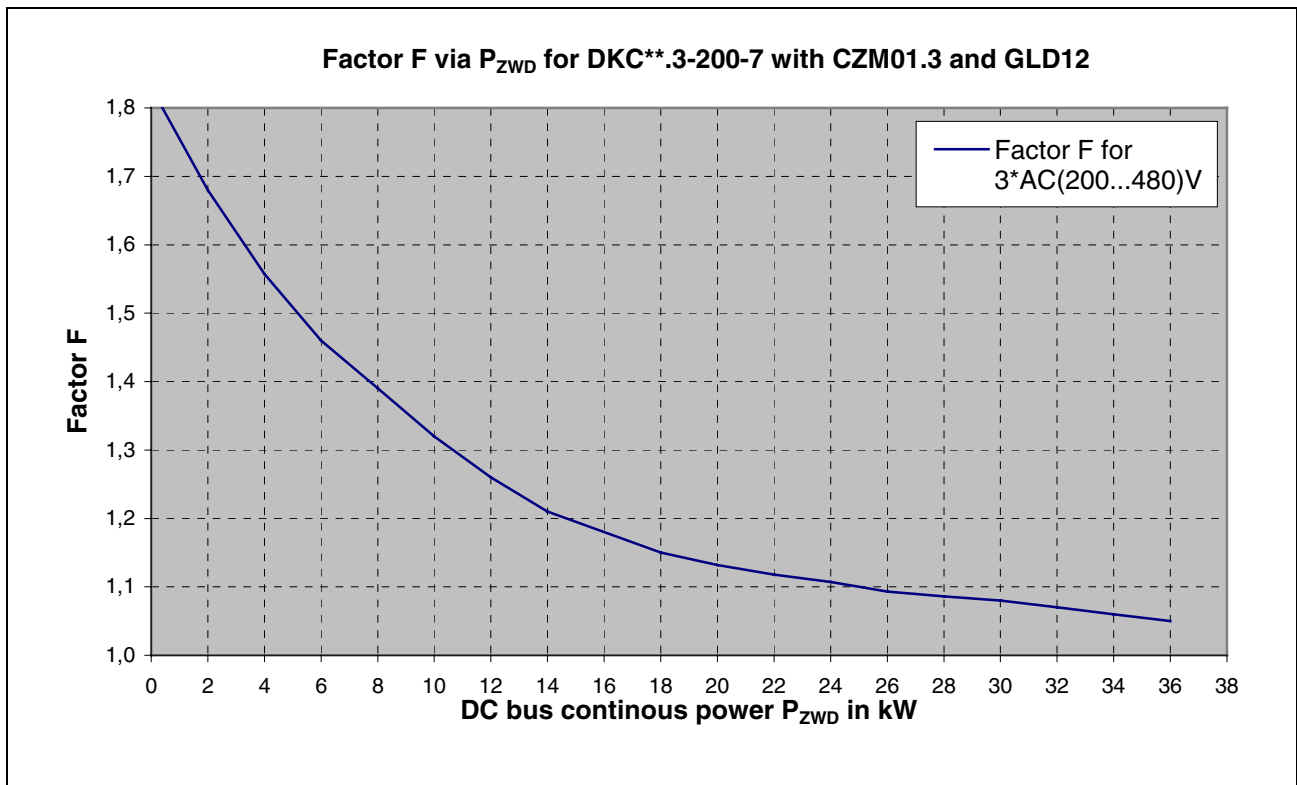

Fig. 11-12: Connected load factor for DKC**.3-200-7 with CZM01.3 and GLD12

Q1 Fuse and K1 Contactor

When selecting a mains contactor and fuses, the continuous current in the supply leads as well as the starting inrush current must be taken into account. Several controllers can be operated on a single fuse and mains contactor. The phase currents and inrush currents of the individual drives must then simply be added up. If a transformer is used, then the fuses and contactors must be installed on the primary side.

The Siemens type fuses and contactors in the selection table below are only examples. Products of equal rating from other manufacturers can be used.

Phase current	Lead cross sections	Fuses (triggering characte. C)	Power fuses	Fusible links (operating class gl)	Mains contactor	Inrush current	Dropout delay t_{Abmax}	Pull-up delay t_{Anmax}
	(1)	(2)	(3)	(2)	(3)			
in A	mm ²	Current in A	Siemens type	Current in A	Siemens type	in A	in ms	in ms
9	1.0	10	3VU1300- .ML00 or 3RV1011-1JA10	10	3TF40 or 3RT1016	54	80	120
12	1.5	16	3VU1300- .MM00 or 3RV1021-4AA10	16	3TF41 or 3RT1017	72	80	120
16	2.5	20	3VU1300- .MM00 or 3RV1021-4AA10	20	3TF42 or 3RT1025	96	110	190
22	4.0	25	3VU1300- .MP00 or 3RV1021-4DA10	25	3TF43 or 3RT1026	132	110	190
32	6.0	32	3VU1600- .MP00 or 3RV1031-4EA10	35	3TF44 or 3RT1034	186	200	120

1. Lead cross sections per EN 60204 – Installation B1 – correction factors not taken into account.
 2. With recommended fuses short-term operating loads can be used by the drive for two minutes. If this is needed for extended periods, then use a bigger fuse.
 3. Allocation "2" per DIN IEC 60947-4: easily separable contact welding at contactors are permitted as a result of short circuits.

Fig. 11-13: Selecting table for Q1 fuses and K1 contactors

Note: To make sure the mains contactor is not overloaded by the load current in the case of frequent switching off, you first have to switch off the drive via the drive enable in the master communication and then switch off the mains contactor.

12 Constructing the Control Cabinet

12.1 Notes on Control Cabinet Project Planning

All ECODRIVE drive components, with the exception of motors, are intended for mounting into a control cabinet. When planning the control cabinet, take the technical data of the drive components into account.

To determine the necessary control cabinet size, not only the mechanical dimensions (dimension sheets, etc.) but also such thermal features as the power dissipation of the individual components, cooling air effluent temperatures and so on must be taken into consideration.

The power dissipation of ECODRIVE03 drive controller are specified in the diagrams on page 12-2.

The temperature increases of the cooling air occurring in the effluent range of the drive controller DKC and the auxiliary braking resistor module BZM are specified in the diagrams "Temperature increase vs. P_{BD} " on page 12-8. The distances to the temperature-sensitive control cabinet components such as leads and cable channels must be maintained.

Power dissipation

Power dissipation is determined by the current load and the regenerated power. The actual generated power dissipation depends on the relevant load cycle, which is limited by the servo motor being used.

On the average, the maximum continuous standstill current I_{dN} of the motor flows through the drive controller

Determining power dissipation

- ⇒ Look up in the relevant motor document both the continuous standstill current I_{dN} and torque M_{dN} .
- ⇒ Determine rms torque M_{eff} of the application (see motor document).
- ⇒ Determine the following relationship current I

$$I = \frac{I_{dN} * M_{eff}}{M_{dN}}$$

Fig. 12-1: Determining current I

- ⇒ Using current I , find the corresponding value of the current-dependent power dissipation $P_{V, DKC}$, using the diagrams "Determining Power Dissipation in the control cabinet".
- ⇒ Add both power losses ($P_{V,DKC}$ and $P_{V,Braking resistor}$). Use the sum ($P_{V,ges}$) when planning the control cabinet.
- ⇒ Consider further components such as smoothing chokes, filters etc.

DKC**.3-016-7-FW
4 kHz

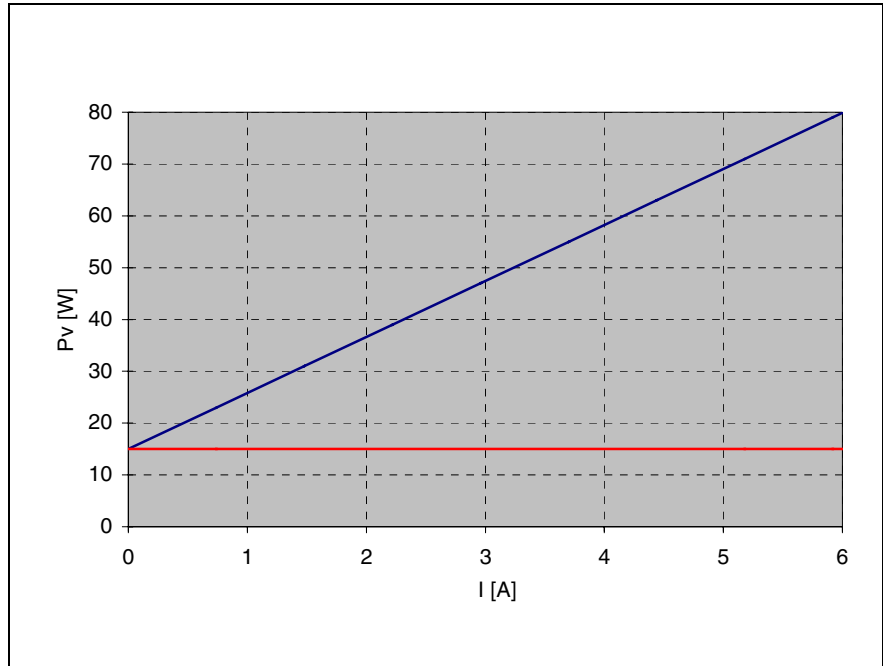

P_v: Power dissipation
I: Current (Sine threshold value)

Fig. 12-2: Determining power dissipation in the control cabinet for each drive controller DKC**.3-016-7-FW without braking resistor power with 4 kHz

DKC**.3-016-7-FW
8 kHz

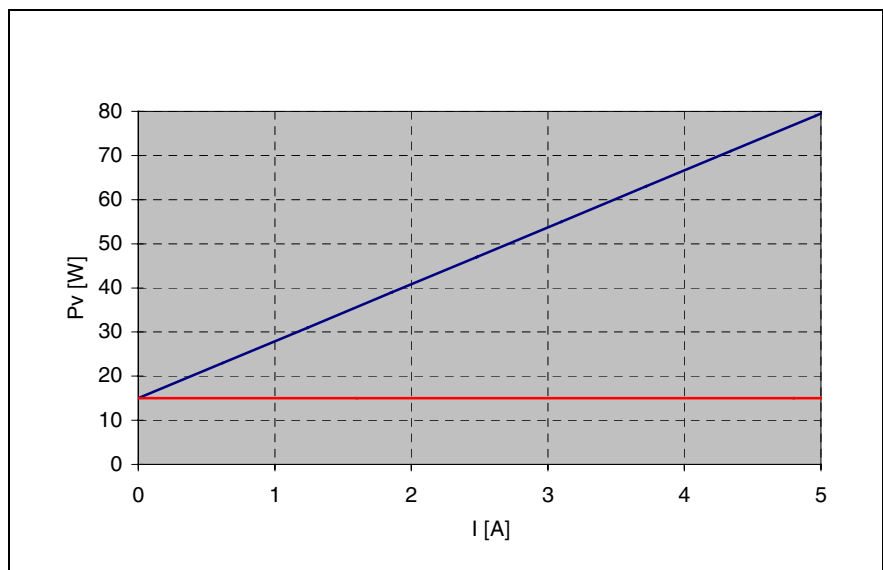

P_v: Power dissipation
I: Current (Sine threshold value)

Fig. 12-3: Determining power dissipation in the control cabinet for each drive controller DKC**.3-016-7-FW without braking resistor power with 8 kHz

DKC**.3-040-7-FW
4 kHz

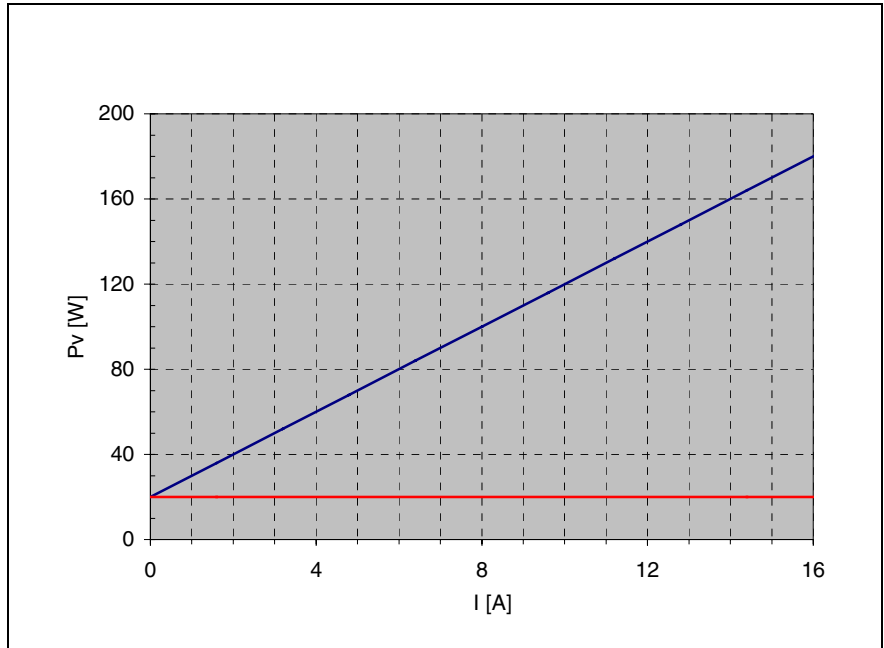

P_v: Power dissipation
I: Current (Sine threshold value)

Fig. 12-4: Determining power dissipation in the control cabinet for each drive controller DKC**.3-040-7-FW without braking resistor power with 4 kHz

DKC**.3-040-7-FW
8 kHz

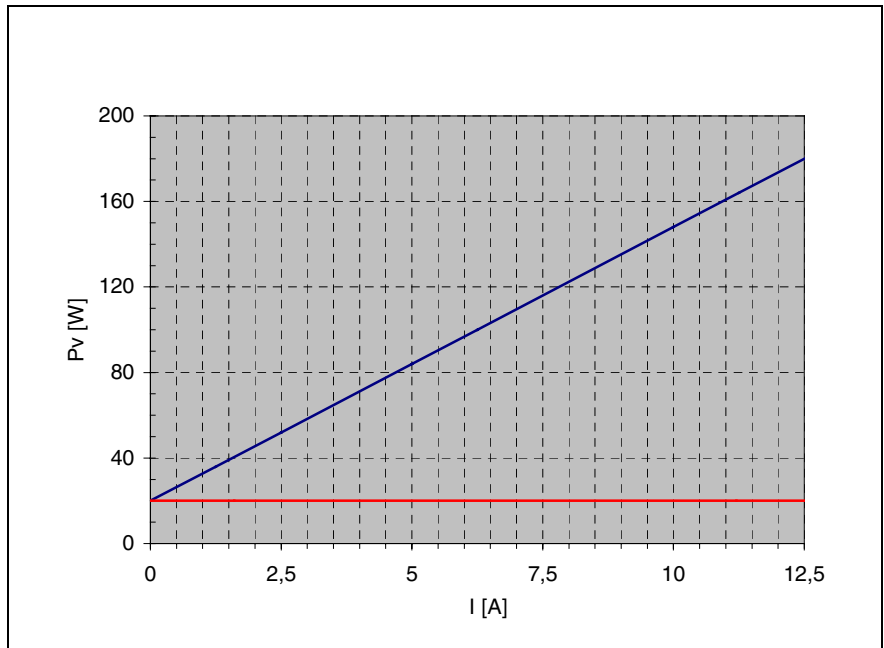

P_v: Power dissipation
I: Current (Sine threshold value)

Fig. 12-5: Determining power dissipation in the control cabinet for each drive controller DKC**.3-040-7-FW without braking resistor power with 8 kHz

DKC.3-100-7-FW**
4 kHz

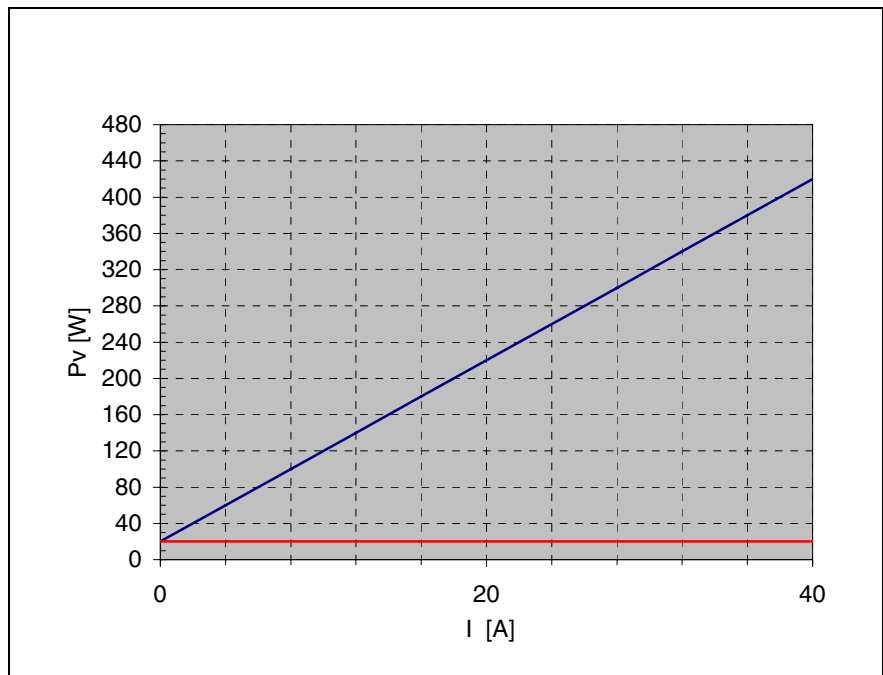

P_v: Power dissipation
I: Current (Sine threshold value)

Fig. 12-6: Determining power dissipation in the control cabinet for each drive controller DKC**.3-100-7-FW without braking resistor power with 4 kHz

DKC.3-100-7-FW:**
8 kHz

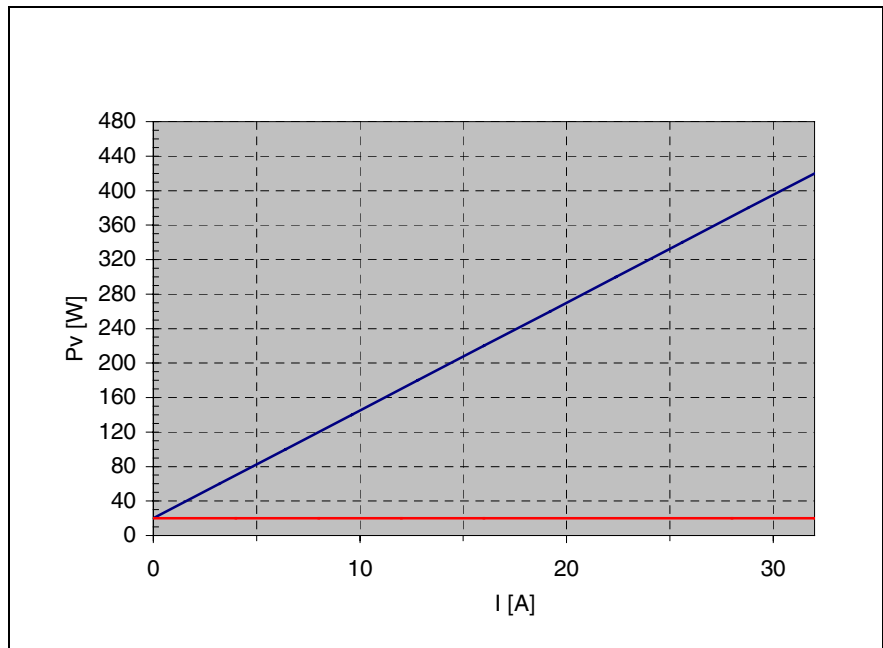

P_v: Power dissipation
I: Current (Sine threshold value)

Fig. 12-7: Determining power dissipation in the control cabinet for each drive controller DKC**.3-100-7-FW without braking resistor power with 8 kHz

DKC**.3-200-7
4 kHz

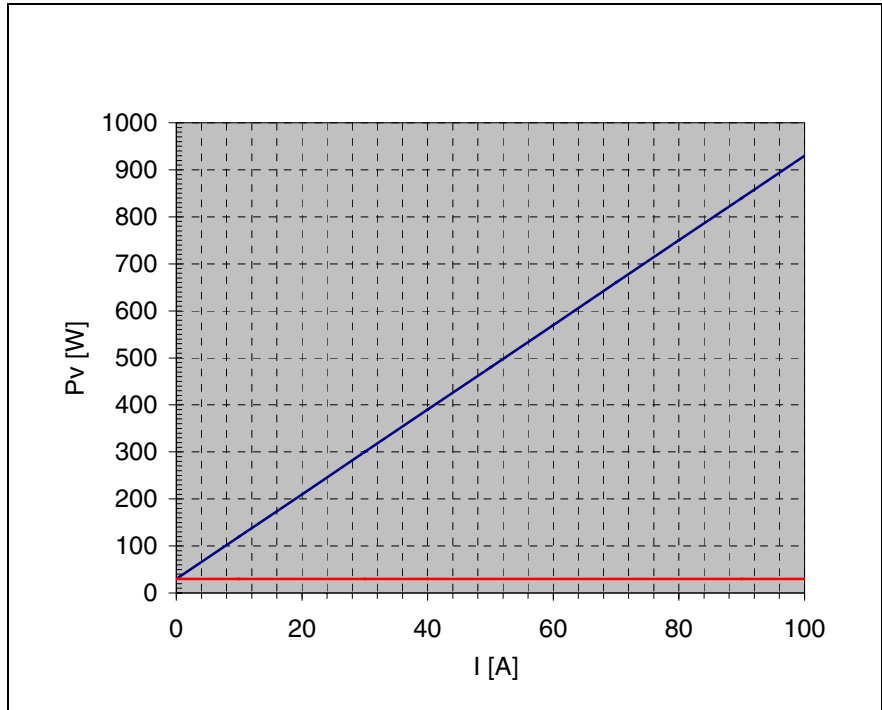

P_v: Power dissipation
I: Current (Sine threshold value)

Fig. 12-8: Determining power dissipation in the control cabinet for each drive controller DKC**.3-200-7-FW without braking resistor power with 4 kHz

DKC**.3-200-7
8 kHz

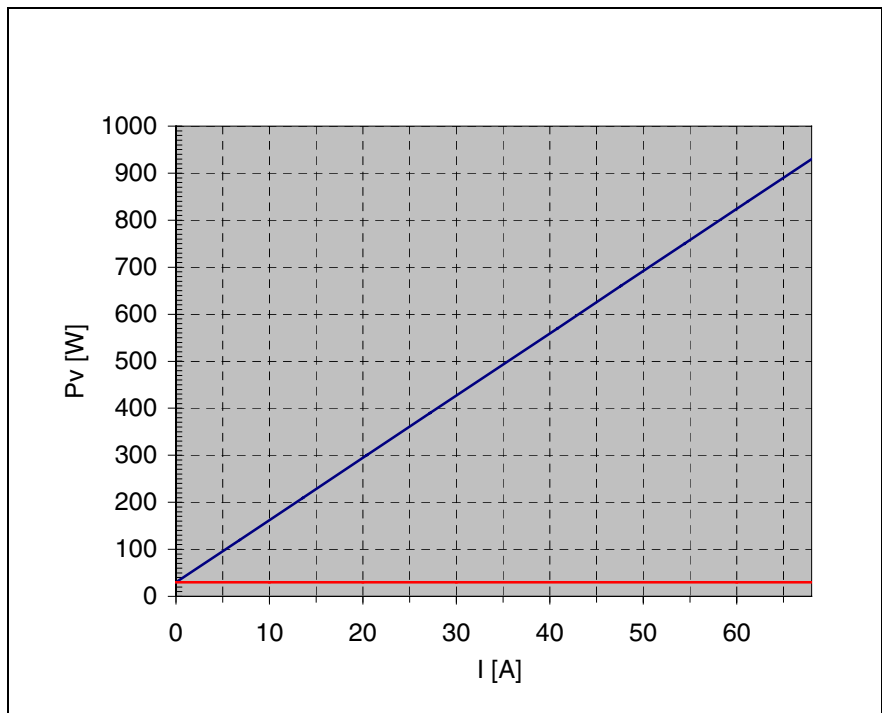

P_v: Power dissipation
I: Current (Sine threshold value)

Fig. 12-9: Determining power dissipation in the control cabinet for each drive controller DKC**.3-200-7-FW without braking resistor power with 8 kHz

Mounting Position and Distances

Mounting Position

- ⇒ The mounting of the drive controller device DKC, the auxiliary braking resistor module BZM and the auxiliary capacitance module CZM is to be performed in such a way that their longitudinal axis correlates with the natural direction of convection (connection block X5 towards the bottom). The natural convection supports the forced cooling air stream. The build up of warm spots in the device is inhibited.
- ⇒ Put the backs of the drive controllers on the mounting surface (mounting plate) of the control cabinet with all-over contact.

Distances

Temperature Increase of Cooling Air

The power dissipation of the drive controller DKC and the auxiliary braking resistor module BZM means that the cooling air from the point of entrance on the underside of the unit until the point of exit on the top side is warmed up. The following illustrates this increase as dependent on the occurring continuous braking resistor power.

- ⇒ The appropriate distance "d" is specified in the curve (interpolation allowed).

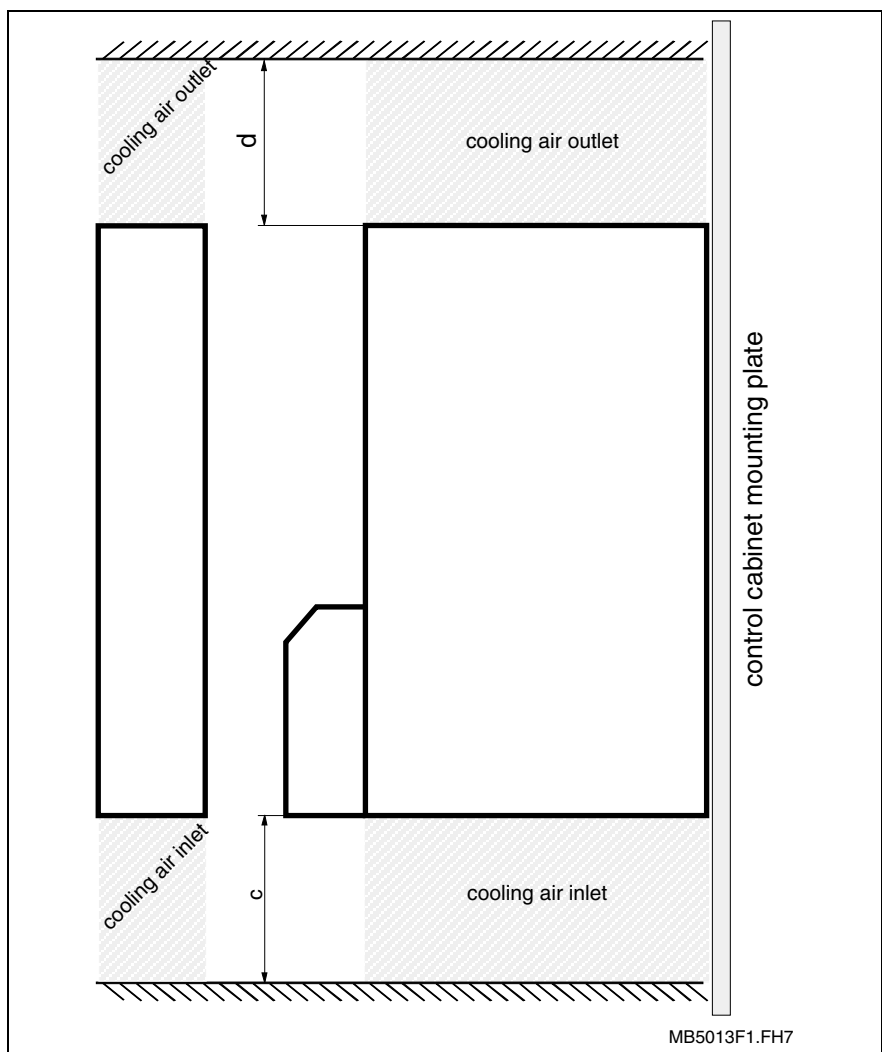

Fig. 12-10: Exit and entrance of cooling air

Note:

- When using the signals at connectors X9, X10 and X11 maintain a minimum distance of $d = 150 \text{ mm}$.
- Without braking resistor power dissipation and connections at X9, X10 and X11 it is possible to reduce distance $d = 80 \text{ mm}$.
- The minimum distance of $c = 80 \text{ mm}$ enlarges itself in dependence of the utilized connection cables.



CAUTION

High temperature

Risk of damage to temperature-sensitive control cabinets in the area of the cooling air outlet.

⇒ Observe the distance "d".

Volumetric capacity of the forced cooling

see also page 4-6: "Electric Data of the Individual DKC**.3 Components" and page 6-3: "Electrical data of auxiliary component BZM01.3".

Note:

Diagram "Temperature increase via continuous braking resistor power" shows the relationship between braking resistor load and temperature of cooling air entering at unit underside and exiting top side under nominal current conditions of the controller.

DKC**.3-016-7-FW

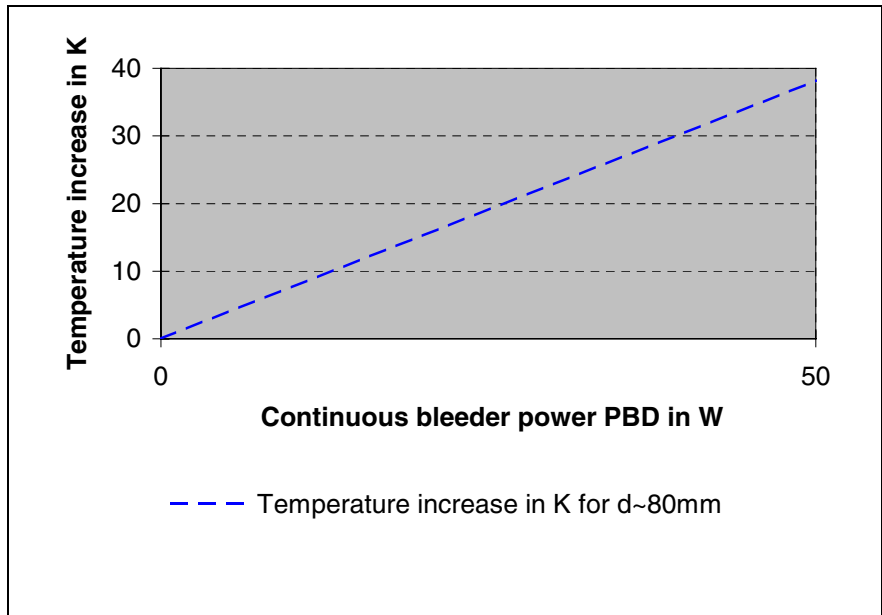

Fig. 12-11: Temperature increase DKC**.3-016-7-FW

DKC**.3-040-7-FW

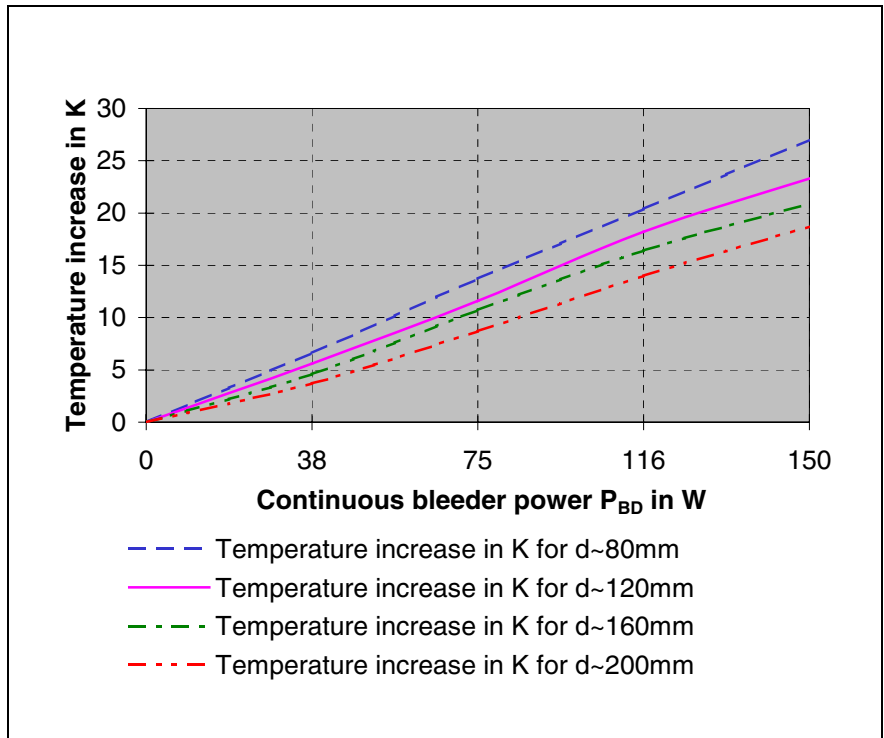

Fig. 12-12: Temperature increase DKC**.3-040-7-FW

DKC**.3-100-7-FW

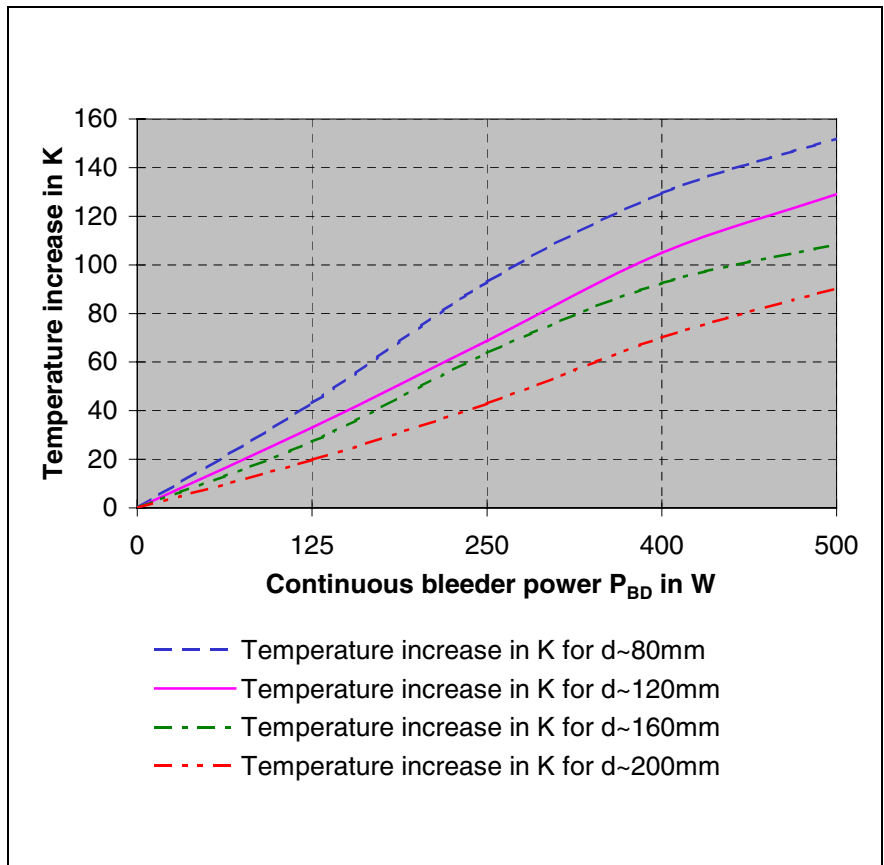

Fig. 12-13: Temperature increase DKC**.3-100-7-FW

DKC**.3-200-7-FW

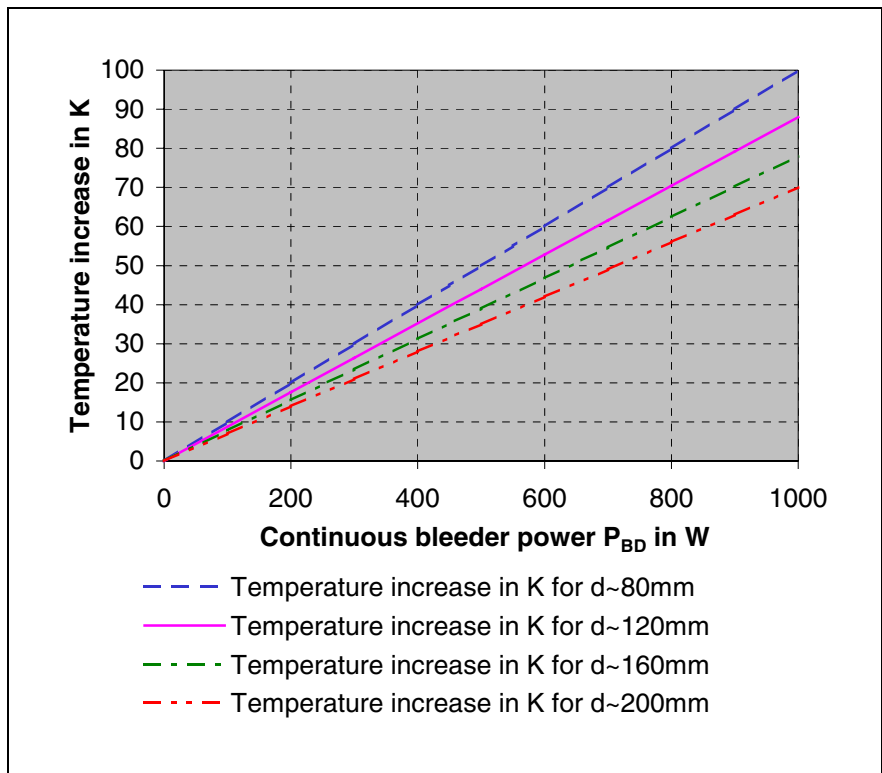

Fig. 12-14: Temperature increase DKC**.3-200-7-FW

BZM**.3-01-7

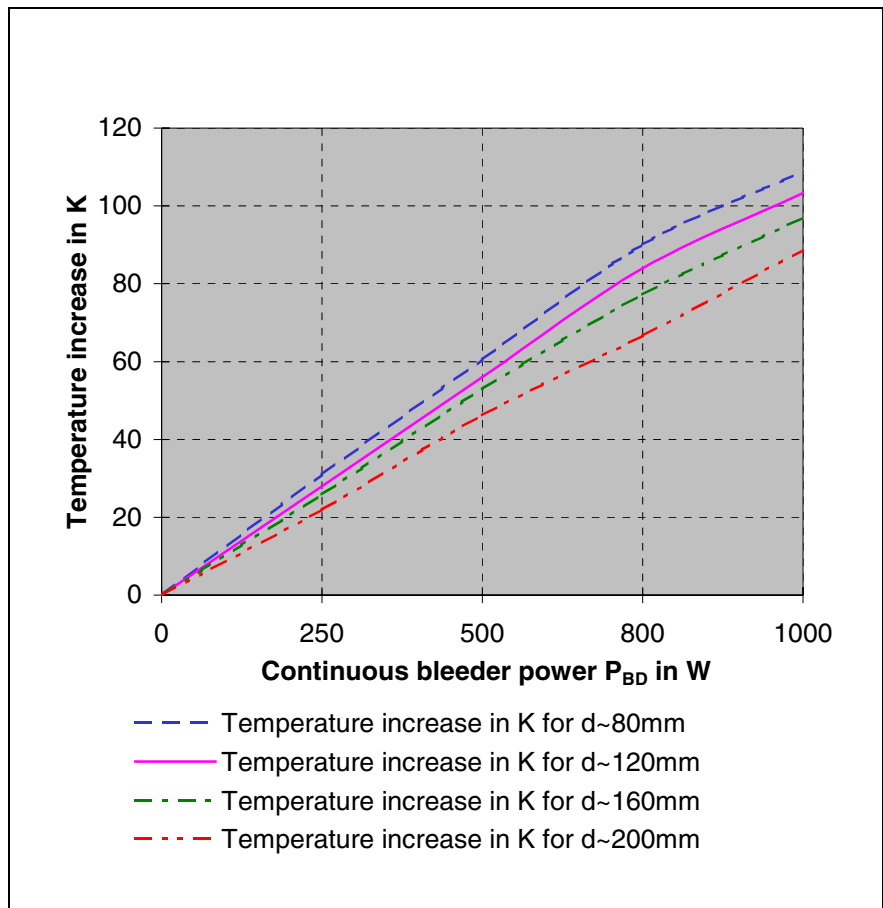

Fig. 12-15: Temperature increase BZM**.3-01-7

Module widths

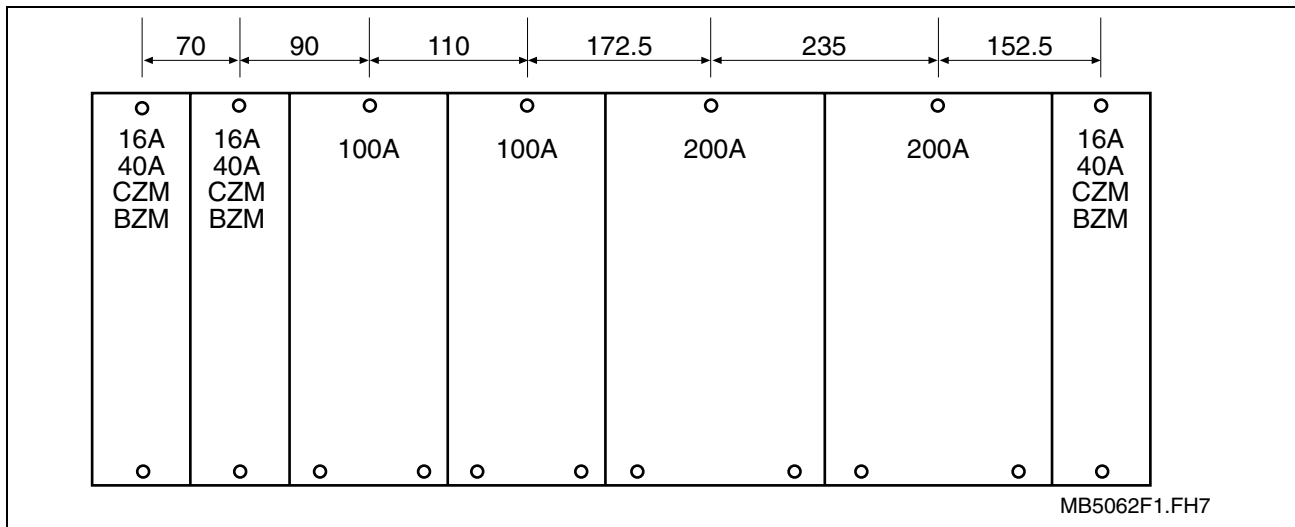

Fig. 12-16: Module widths

Note: Using the specified increments, there is a distance of 5 mm between the units.

In order to observe the specified vibration fatigue limit (see page 4-5), please note the following:

- In case fastening screws are part of the drive controller's scope of supply, you have to use these screws for mounting the drive controller.
- In the case of the DKC**.3-100 and DKC**.3-200 drive controllers, you have to use the two outer fastening holes.

Arranging ECODRIVE03 Components in the Control Cabinet

Multiple Row Construction of the Control Cabinet

Note: In particular when arranging ECODRIVE03 components in multiple rows within the control cabinet, it is important to note the entrance temperature (see technical data) and, if necessary, mount air guiding plates with blowers.

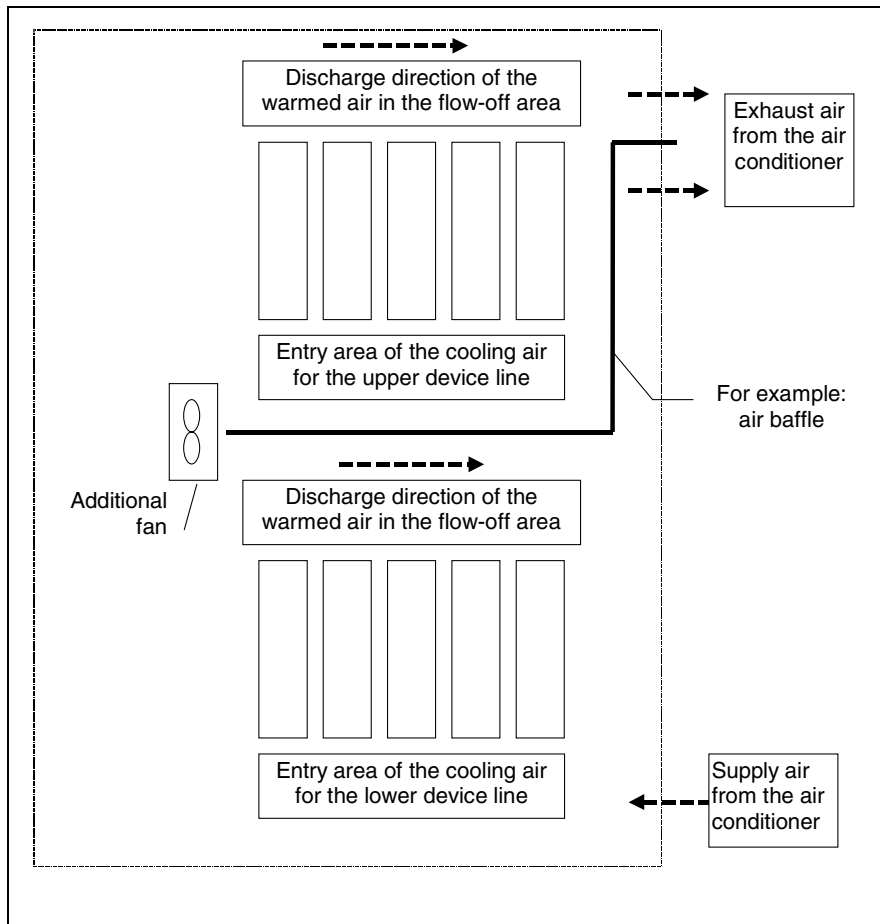

Fig. 12-17: Example of arranging ECODRIVE components in multiple rows

See also page 16-7: "Control Cabinet Construction with Recommendations for EMC and Cooling".

Power-dependent arrangement

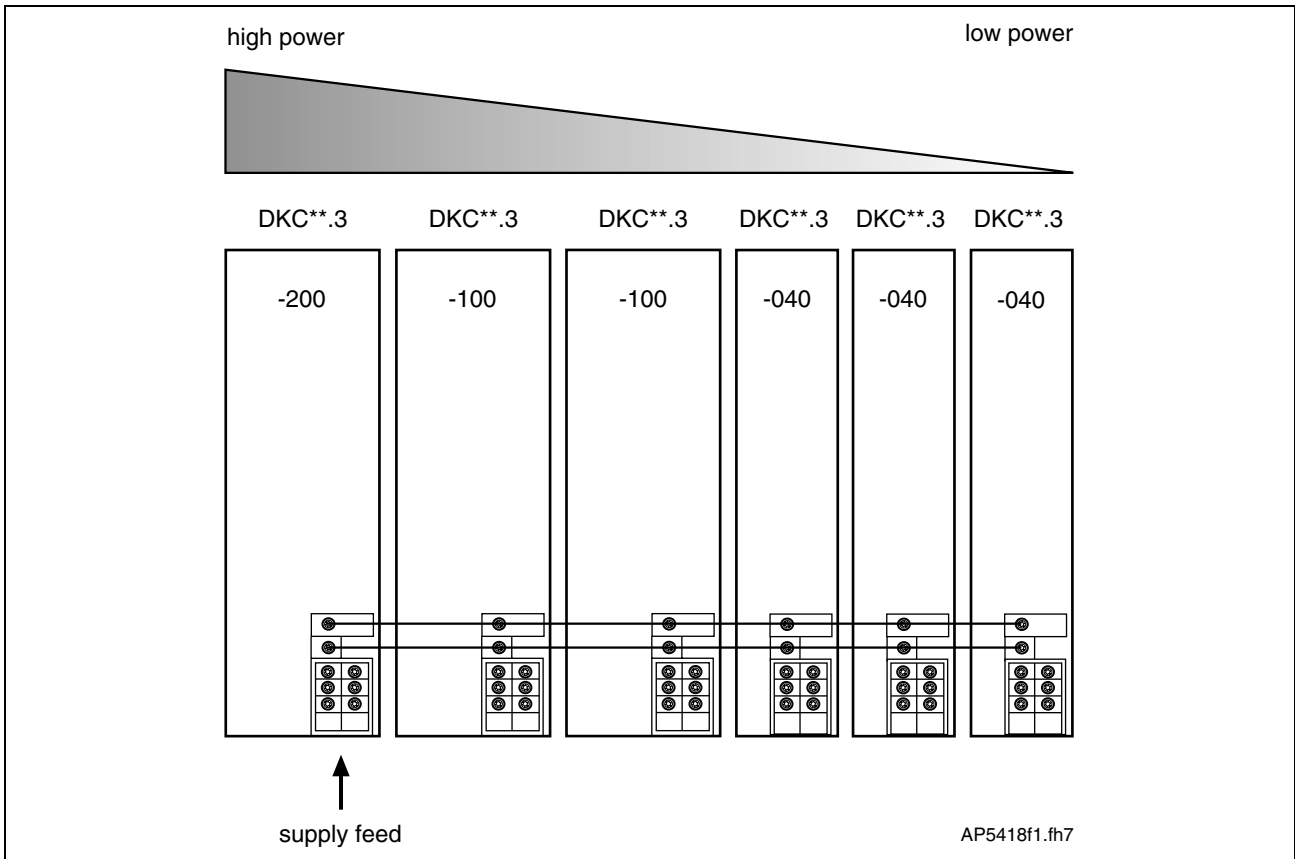

Fig. 12-18: Example of arrangement of a "Central feed"

- For mounting details please see page 4-21 onward.
- Arrange auxiliary capacitance module CZM next to drive with large DC bus continuous power.
- Arrange auxiliary braking resistor module BZM next to drive with large feedback power.

See also page 16-7: "Control Cabinet Construction with Recommendations for EMC and Cooling".

12.2 Using Cooling Units in the Control Cabinet

The controller may only be operated if the ambient temperature does not exceed 45 °C. Otherwise temperature must be reduced and it may be necessary to use a cooling unit.



CAUTION

Possible damage to controller

Endangers the operating safety of the machine
⇒ Note the following information!

Avoiding dripping or spraying water

Under normal conditions, if a cooling unit is used, then water condensation occurs. Therefore, note the following:

- Always arrange cooling so that water condensation cannot drip onto electronic units within the cabinet.
- Place the unit so that the cooling unit blower cannot spray condensation onto electronic components.

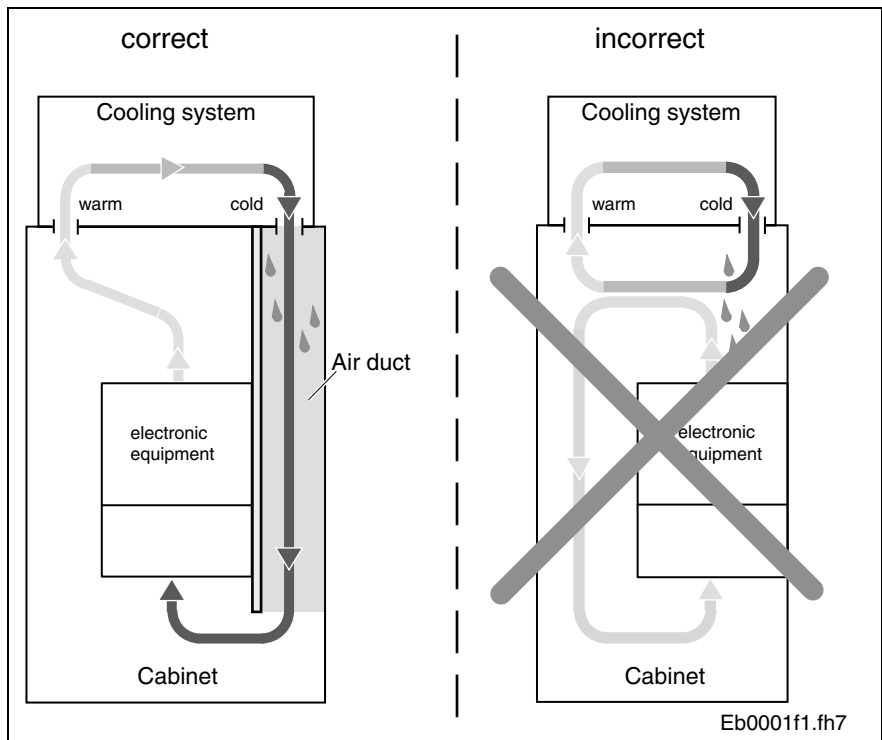

Fig. 12-19: Arranging cooling unit on cabinet

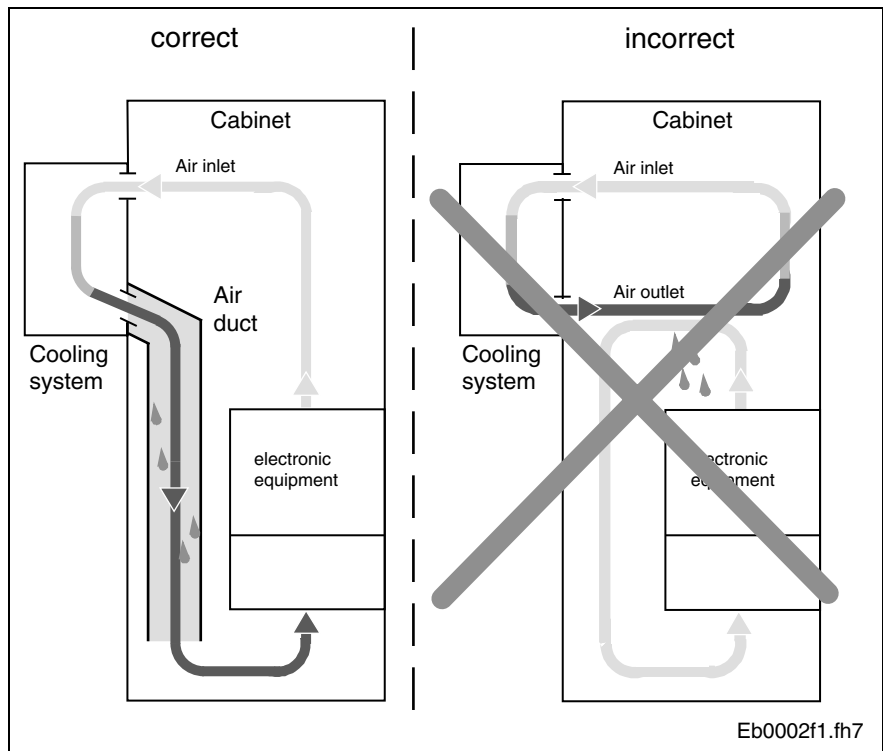

Fig. 12-20: Arranging cooling unit on front of cabinet

Avoiding condensation

Condensation occurs if the temperature of the unit is lower than the ambient temperature.

- Cooling units with temperature settings must be set to maximum room temperature and no lower!
- Cooling units with temperature must be set so that the inside temperature of cabinet is not lower than the outside temperature. Set temp limit to maximum room temperature !
- Use only well-insulated cabinets to avoid condensation resulting from humid outside air penetrating the cabinet.
- If cabinets are operated with doors open (commissioning, service, etc.), then make sure that once the doors are closed the controller is at no point in time cooler than the air in the cabinet. This avoids condensation build up. In other words, ensure sufficient circulation in the cabinet to avoid any hot spots.

12.3 General Notes

Electrostatic discharge from persons and/or tools can damage the controller or printed circuits boards (PCB). Please note the following:



CAUTION

Risk of damaging the electronic components and endangering the operating safety caused by electrostatic charges!

⇒ Objects coming into contact with machine parts and PCB must be discharged by grounding them. Otherwise errors can occur when controlling motors and elements in motion.

Such objects can be:

- The soldering iron when soldering
- The human body (ground by touching a conductive, grounded object).
- Parts and tools (place on conductive surface)

Parts at risk may only be stored and shipped in conductive packaging.

Note: The diagrams of Rexroth Indramat should only be used by a Machine Manufacturer to create terminal diagrams for a facility. When wiring a facility, an End user should only use the diagrams of the Machine Manufacturer.

General notes

- Route signal lines separately from load lines to avoid interference.
- Conduct analog signals (e.g., command/actual values) via shielded leads.
- Mains, DC bus and power lines should not be connected to low voltages or come into contact with them.
- When conducting a high voltage test or external voltage capacity test of the electrical components of the machine, disconnect or remove all connections of the units. This protects the electronic components (allowed as per EN 60204-1). Rexroth Indramat drive components are high-voltage and insulation tested as per EN 50178.



CAUTION

Potential damage of the controller device by connecting and disconnecting the connections with mains power on.

⇒ Do not connect and disconnect connections if the mains power is on.

12.4 Wire routing in the Control Cabinet

- A distance of at least 100 mm between power and control or signal cables (e.g., feedback cables) must be maintained or
- Separate cable duct with metal divider.

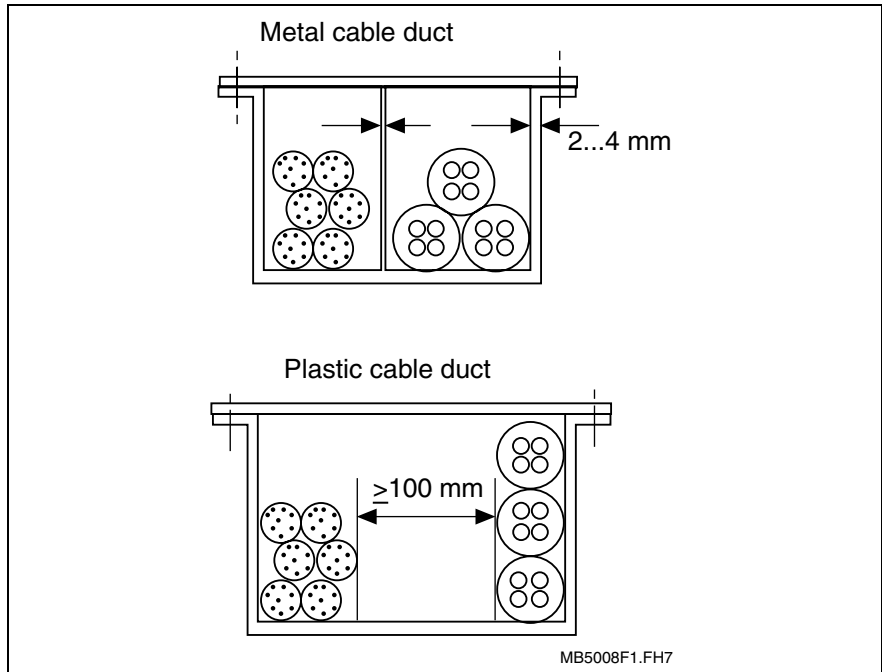

Fig. 12-21: Cable duct variant

Note: Details are specified in the project planning manual "Electromagnetic compatibility (EMC) or AC drives", doc. Type DOK-GENERL-EMV*****-PRxx.

12.5 EMC in the Control Cabinet

Note: Details are specified in the project planning manual "Electromagnetic Compatibility (EMC) in Drive and Control Systems", doc. type DOK-GENERL-EMV*****-PRxx.

Notes

13 State of Delivery of the Drive Components

13.1 Packaging

- Units** ECODRIVE03 components come in separate units.
- Material** Rexroth Indramat takes the packaging material back free of charge. The customer is charged for the return transport.
- Sticker** The barcode sticker on the packaging lists the contents of the components and the order number.



Fig. 13-1: Barcode sticker on the packaging - breakdown

13.2 Papers

There is an envelope on one of the packages which contains two copies of the delivery slip. There are no more papers.

On the delivery slip or freight papers, the entire number of transport containers is specified.

13.3 Extent of Delivery

Included in the delivery:

- **The controller DKC**.3**
 - With firmware module (integrated in the case of DKC**.3-016)
 - With contact protection (not for DKC**.3-016)
 - with connectors according to the following table

DKC**.3-016-7-FW:

Type	Connectors - type independent X..									Connectors - type dependent X..								
	1	2	3	4	5	6		10		15	20	21	30	40	41	50	60	210
DKC01.3-***-7	X		X		X	X		X		X								
DKC02.3-***-7	X		X		X	X		X										
DKC03.3-***-7	X		X		X	X		X										
DKC04.3-***-7	X		X		X	X		X										
DKC05.3-***-7	X		X		X	X		X										
DKC06.3-***-7	X		X		X	X		X									X	
DKC21.3-***-7	X		X		X	X		X										
DKC22.3-***-7	X		X		X	X		X										

Fig. 13-2: Connectors for DKC**.3-016-7-FW included in the delivery

DKC**.3-040/100/200-7-FW:

Type	Connectors - type independent X..										Connectors - type dependent X..								
	1	2	3	4	6	8	9	10	11		15	20	21	30	40	41	50	60	210
DKC01.3-***-7	X		X	X	X	X	X	X	X		X								
DKC02.3-***-7	X		X	X	X	X	X	X	X										
DKC03.3-***-7	X		X	X	X	X	X	X	X										
DKC04.3-***-7	X		X	X	X	X	X	X	X										
DKC05.3-***-7	X		X	X	X	X	X	X	X										
DKC06.3-***-7	X		X	X	X	X	X	X	X									X	
DKC11.3-***-7	X		X	X	X	X	X	X	X										
DKC21.3-***-7	X		X	X	X	X	X	X	X										
DKC22.3-***-7	X		X	X	X	X	X	X	X										

Fig. 13-3: Connectors for DKC**.3-040...200-7-FW included in the delivery

- Connection and mounting accessories according to the enclosed packing slip (sample)



SUP-M01-DKCXX.3-040



276963

Stck	Benennung	MN
5	KABELBINDER TY- 25M	222614
2	SCHELLE-SCHLAUCH DIN 3017 12-22MM	274471
2	SCHIENE-VERSORG. 74 CU ISOL.	277743
2	SCHR-LIN-M 6,0X25,0-K-8-8-ISO7045-ZN-Z4	276873
1	INS0519/L01 (CN-0015S-DSUB-SCREW-****)	263365
1	INS0439/L01 (CN-0015P-DSUB-SCREW-****)	252884
1	DOK-GENERL-DRIVE*****-SVS1-MS-P	271404

Stck	Benennung	MN
1	DOK-GENERL-DRIVE*****-SVS1-MS-P	271404
1	INS0439/L01 (CN-0015P-DSUB-SCREW-****)	252884
1	INS0519/L01 (CN-0015S-DSUB-SCREW-****)	263365

Stck	Benennung	MN
5	KABELBINDER TY- 25M	222614
2	SCHELLE-SCHLAUCH DIN 3017 12-22MM	274471
2	SCHIENE-VERSORG. 74 CU ISOL.	277743
2	SCHR-LIN-M 6,0X25,0-K-8-8-ISO7045-ZN-Z4	276873
1	INS0520/L01 (CN-0025P-DSUB-SCREW-****)	263366

Stecker:
MN 263366
INS0520/L01 (CN-0025P-DSUB-SCREW-****)
ist Bestandteil dieser Lieferung

nur bei Geräetetype: - DKC01.3-XXX-7-FW

Datum	20-Apr-00	Benennung
Name	Merz	BEIPACKZETTEL SUP-M01-DKC**.3-040
Material-Nr.	276964	Zeich-Nr. 109-1039-4208-03
Datei	DB113263	Ers.durch .. AEM-Nr.

BP0001F1.FH7

Fig. 13-4: Packaging slip SUB-M01-DKCxx.3-040 (sample)

DOK-ECODR3-DKC**.3****-PR05-EN-P



13.4 Ordering

Unit Types Available

DKC01.3-016-7	DKC01.3-040-7	DKC01.3-100-7	DKC01.3-200-7
DKC02.3-016-7	DKC02.3-040-7	DKC02.3-100-7	DKC02.3-200-7
DKC03.3-016-7	DKC03.3-040-7	DKC03.3-100-7	DKC03.3-200-7
DKC04.3-016-7	DKC04.3-040-7	DKC04.3-100-7	DKC04.3-200-7
DKC05.3-016-7	DKC05.3-040-7	DKC05.3-100-7	DKC05.3-200-7
DKC06.3-016-7	DKC06.3-040-7	DKC06.3-100-7	DKC06.3-200-7
-	DKC11.3-040-7	DKC11.3-100-7	DKC11.3-200-7
DKC21.3-016-7	DKC21.3-040-7	DKC21.3-100-7	DKC21.3-200-7

Note: List of available types is constantly being expanded, please request current status from a sales office of Rexroth Indramat GmbH.

Replacement Parts

- Contact protection
- Connecting and mounting accessories SUP-M**-DKC**.3-040
- Connecting and mounting accessories SUP-M**-DKC**.3-100
- Connecting and mounting accessories SUP-M**-DKC**.3-200
- Connecting and mounting accessories SUP-E01-DKC**.3
- Connecting and mounting accessories SUP-E02-DKC**.3
- Firmware module ESM 2.* (not for DKC**.3-016-7-FW)

Additional Accessories

- Standard interface cables IKB0005/length four different lengths for RS232 (2 m, 5 m, 10 m or 15 m)
- Interface cable RS485 INK0572/ length (not for DKC**.3-016-7-FW)

Mounting Accessories

A Torx screw driver TX30 with a 400 mm long blade is available.

- Torx screw driver TX30 M6 400 lg (MN00282391)

Commissioning Aids

- Command value box (not for DKC**.3-016-7-FW)
- DriveTop (Software for start-up)

14 Identifying the Components

14.1 Component designations

Every drive component is labelled with a type designation.

There is a type plate on every unit including the motor.

There is a label around the standard cable (cable brand). Type designation and length is on this label. (The designation of the actual cable without connector is printed on the cable sheath.)

The accessories in the bags are either identified with their ID on the bag or there is a packaging slip.

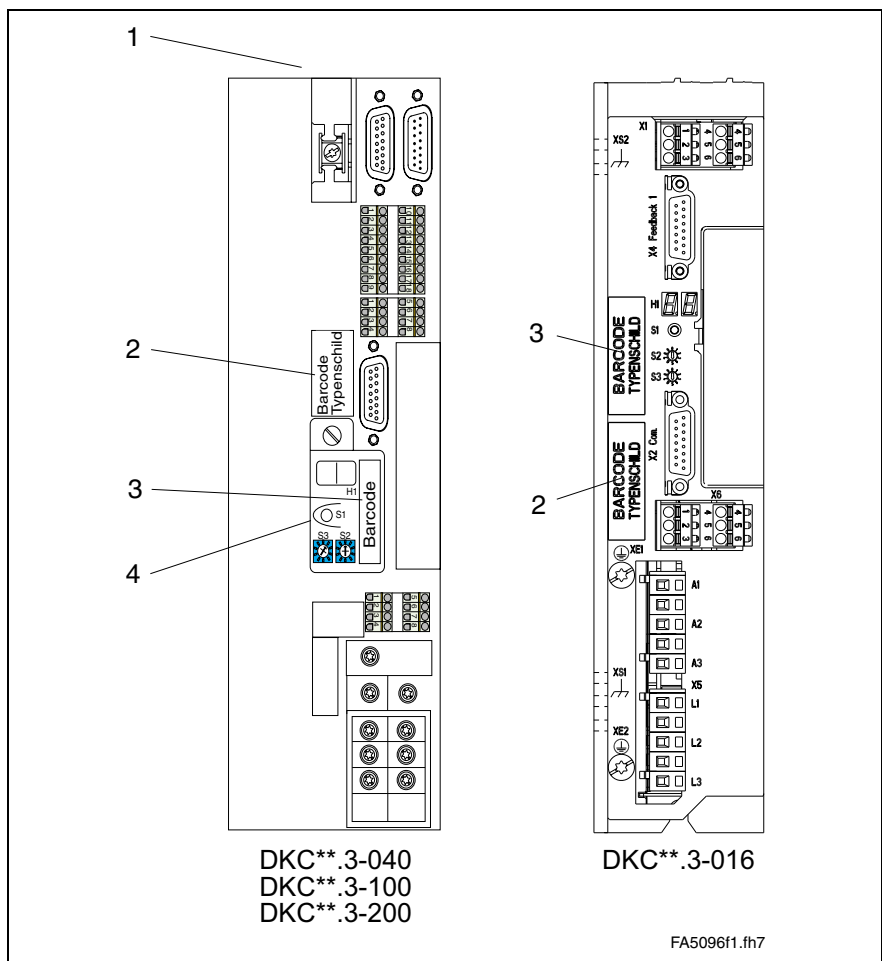

1: Basic unit – type plate
 2: Unit design – type plate
 3: Firmware – type plate
 4: Programming module – type plate
 Fig. 14-1: Type plates

Type Plates

(1) Basic Unit

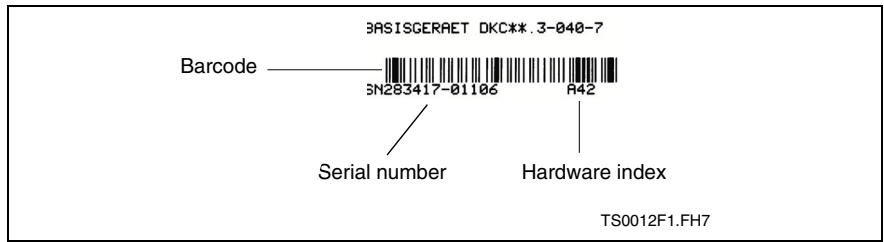

Fig. 14-2: Type plate

(2) Unit type

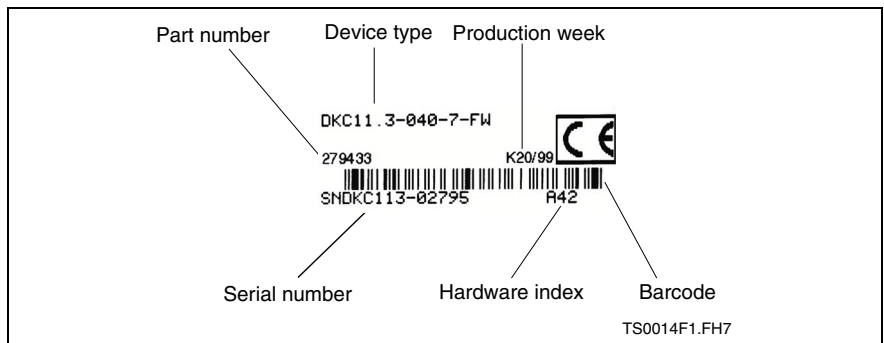

Fig. 14-3: Type plate – DKC example

Note: The type plates for units BZM, CZM, NTM, NFD/NFE is the same.

(3) Firmware

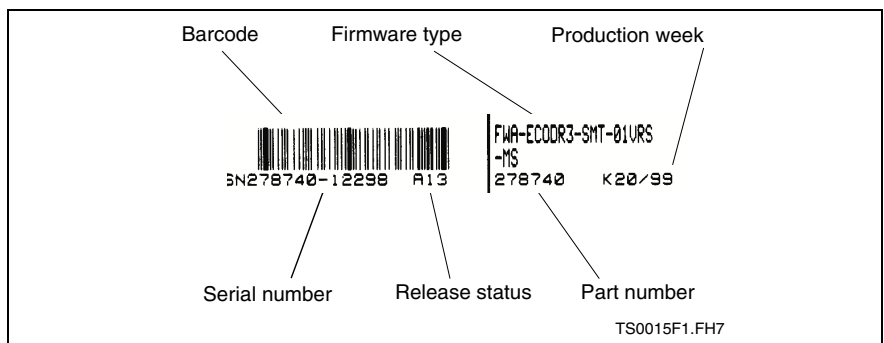

Fig. 14-4: Type plate

(4) Programming Module

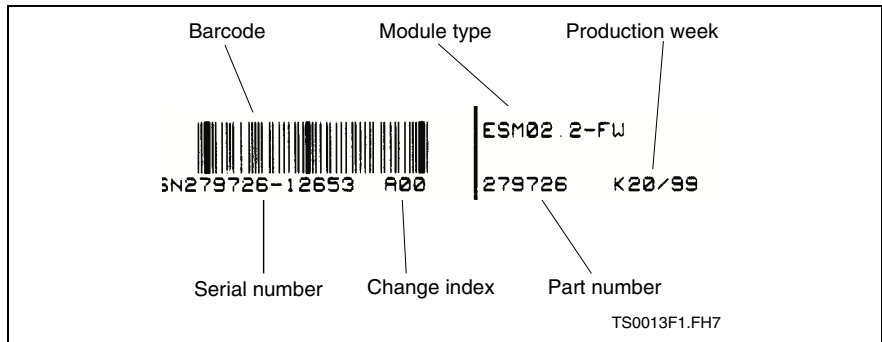

Fig. 14-5: Type plate

DST/DLT

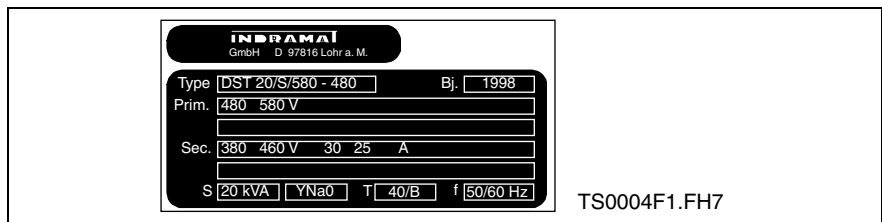

Fig. 14-6: Type plate DST/DLT

Notes

15 Replacing or Exchanging Drive Components

15.1 General

The diagnostic display enables an aimed and effective problem search in order to:

- avoid production downtimes due to extensive searches in individual units and repairs of units on the machine
- assume operations without extensive assembly and adjustments
- to quickly eliminate the problem, and replace the defective component

When returning a defective unit to Indramat Customer Service, please complete the Fault Report in its entirety. This fault report is this section (see page 15-6) and may be copied for your convenience.

Note: The new drive components must have the same type designations as the old! To ensure this, register the entire type designation when requesting a replacement part.

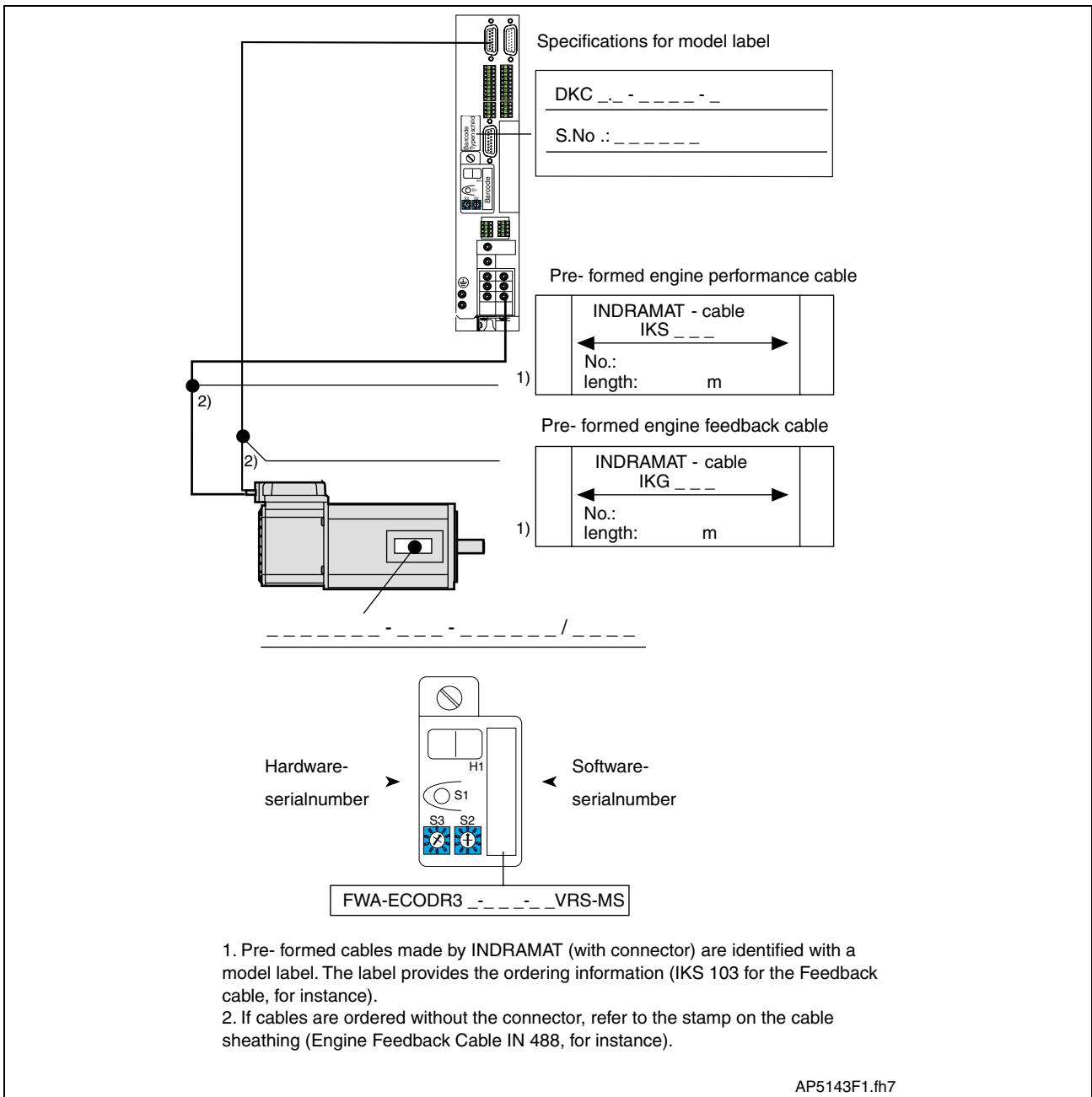

Fig. 15-1: Type designations of the drive components

15.2 Procedure on Replacing the Unit

Note: Note the safety instructions in section 3 when exchanging any parts!

Replacing the drive controller

- Make sure the drive controller is completely de-energized.
- Switch main switch off.
- Secure against being switched back on.



DANGER

Lethal electric shock caused by charged capacitor!

⇒ Prior to touching bear connecting cables and terminals, wait for the capacitor to discharge! Only then work on the cables!

- Remove contact protection and separate connecting line from the drive controller.
- Release screws on top and bottom of housing.
- Remove the drive controller.
- Insert programming module from defective drive controller into new one. This eliminates the reloading of parameter files. If the programming module is defective, see "Replacing Firmware" on page 15-7.
- Hand new drive controller into place and tighten screws.
- Connect drive controller as specified in the machine terminal diagrams.
- Start up installation.

Replacing the Motor

- Switch main switch off.
- Secure against being switched back on.
- Disconnect plug-in connectors.

Note: When replacing the motor, cap open connector ends particularly if there might be the change that coolant or grease could be sprayed or splashed in their vicinity (allowable level of dirt contamination is V2 (according to DIN VDE 0160)).

- Replace motor.

Note: To mechanically replace the AC servo motor, note the instructions of the machine manufacturer.

- Connect plug-in connectors.



Danger of unwanted movements!

⇒ Servo axes with an indirect path measuring systems via a motor encoder will lose the reference dimension if the motor is replaced! This reference to machine coordinate system must therefore be reestablished.

- Servo axes with absolute motor encoder:
Reestablish the absolute reference

Replacing cables



Danger from high-voltage levels.

⇒ Power connector of the cables may only be inserted or separated if power in the installation has been shutdown!

Note: When replacing cables, note the instructions of the machine manufacturer.

If a standard cable from Rexroth Indramat is not used, then check to ensure that the cable agrees with the terminal diagram of the machine manufacturer!

- Switch main switch off.
- Secure against being switched back on.
- Disconnect plug-in connectors.

Note: When replacing the motor, cap open connector ends particularly if there might be the change that coolant or grease could be sprayed or splashed in their vicinity (allowable level of dirt contamination is V2 (according to DIN VDE 0160).

- Replace cables
- Connect plug-in connectors

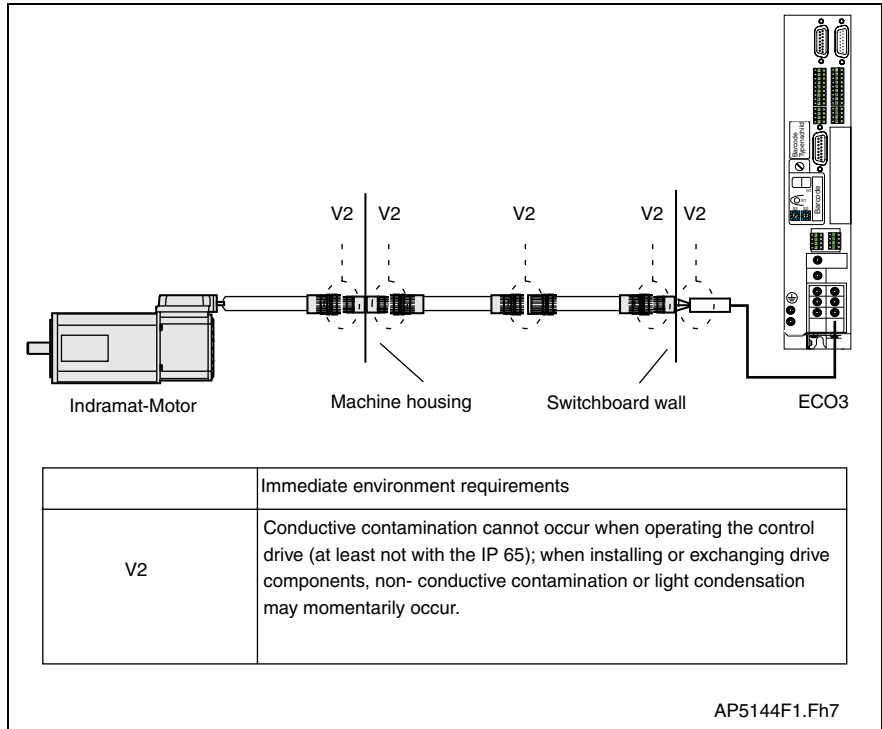



Fig. 15-2: Dirt contamination per DIN VDE 0160



ATTENTION

Property damage caused by bad power connectors!

⇒ Connect power connections only when they are dry and clean.

Fault Report for digital AC Servo Drives DKC

This fault report is intended to clarify problems and their causes. It is absolutely necessary for finding and eliminating hidden, sporadic or application-related problems.

- Always include a Fault report with any parts returned for repair.
- Otherwise, send Fault Reports to your Rexroth Indramat representative

Fault Report dated:	Co.:	Loc.:	Date:
	Dept.:	Name:	Tel.:

Information about the drive:

Data on rating plate

Enter display data at time problem occurred

H1	
----	--

Hardware-S.N. _____

X5 DC bus connection mains connection:
 single phase
 three-phase

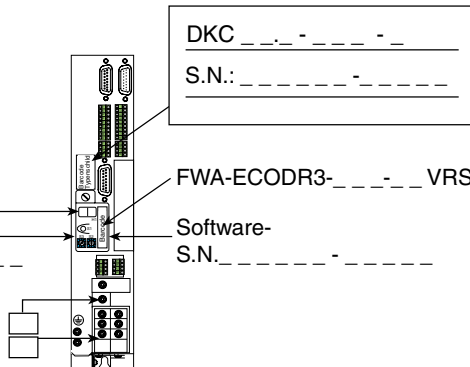

Info about motor:

Motor type: _____

S. No.: _____

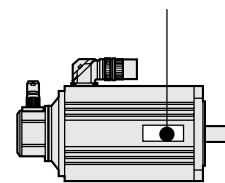

Information about machine at which problem occurred:

Machine manuf.: _____ Type: _____ Oper. hours: _____

Machine number: _____ Comm. date: _____

Manufacturer and type of machine control: _____

Designation of the machine axis in which fault occurred: _____

Describe the problem:

Additional data:

Problem:	Causes:	Auxiliary problems:	
<input type="checkbox"/> always present <input type="checkbox"/> at startup <input type="checkbox"/> occurs sporadically <input type="checkbox"/> occurs after <input type="checkbox"/> hrs. <input type="checkbox"/> with vibrations <input type="checkbox"/> depends on temperature	<input type="checkbox"/> unknown <input type="checkbox"/> incorrect connection <input type="checkbox"/> external cause <input type="checkbox"/> mechanical damage <input type="checkbox"/> loose cable connection <input type="checkbox"/> moisture in unit <input type="checkbox"/> foreign object in unit	<input type="checkbox"/> problem in the mechanical system <input type="checkbox"/> power section failure <input type="checkbox"/> control system failure <input type="checkbox"/> motor failure <input type="checkbox"/> cable break <input type="checkbox"/> defective blower <input type="checkbox"/> defective feedback	Is there an air conditioner in the cabinet ? Y / N <input type="checkbox"/> Have there been previous problems at this machine ? How often: _____ Did the problems occur on the same day or the same time of the day ? _____ _____ _____
<input type="checkbox"/> Additional data: _____ _____ _____ _____			

Pi6005f1.fh7

Fig. 15-3: Fault report

15.3 Replacing Firmware (DKC**.3-040/100/200-7-FW)

Replacing the Parameter Module

- Secure parameters (DriveTop)
- Switch drive controller off
- Remove programming module
- Open the lock on the back

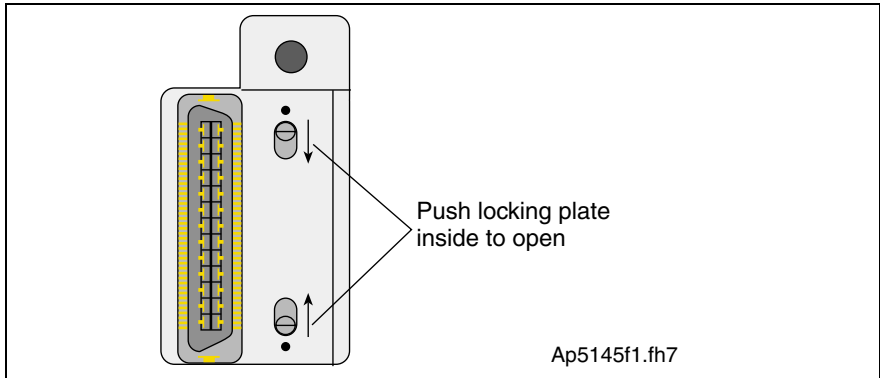

Fig. 15-4: Locking the programming module

- Open the programming module

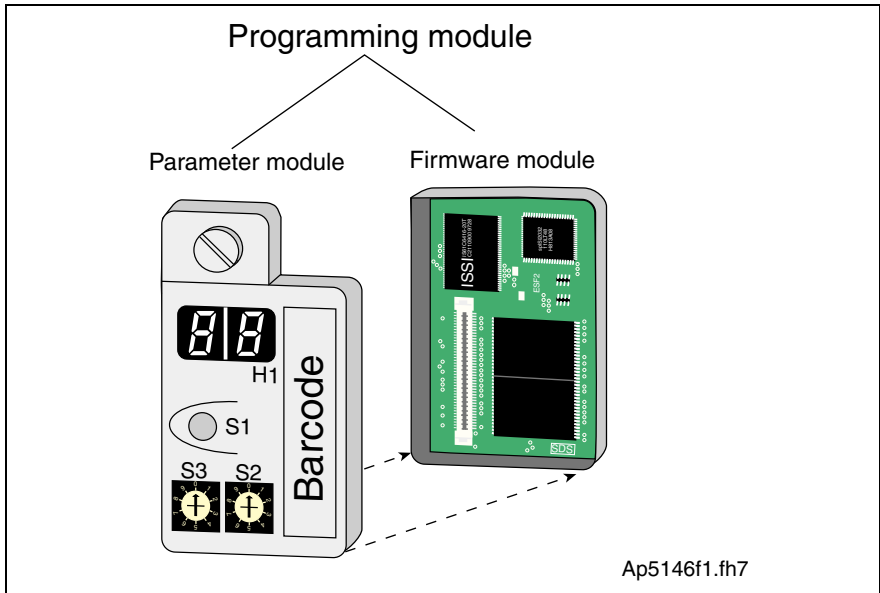

Fig. 15-5: Programming module

- Connect new parameter module and old firmware module
- Close lock (switch outward)
- Insert programming module
- Switch drive controller on
- Load parameters (DriveTop)

Replacing the Firmware Module

- Switch drive controller off
- Loosen screw at programming module and pull programming module out
- Pull programming module out
- Open the lock on the back of the programming module
- Open the programming module
- Insert old parameter module into new firmware module
- Close lock (lock must be pushed outward)
- Insert programming module and screw on
- Switch drive controller on

Replacing the Programming Module (complete module)

- Secure parameters (DriveTop)
- Switch drive controller off
- Loosen screw at programming module and pull programming module out
- Insert new programming module
- Switch drive controller on
- Load parameters (DriveTop)

15.4 Replacing Firmware (DKC**.3-016-7-FW)

- Secure parameters (DriveTop)
- Set Parameter *P-0-4021, Baud-Rate RS-232/485* to 0 (Baud rate 9600)
- Close DriveTop
- Start DOLFI
- Press Button "Connect"
- Open IBF-file of the firmware by pressing button "Open file"
- Transfer the three files of the IBF-file by pressing button "Transfer file" and confirm the transfers.
- In event of download problems you have to reduce the Baud rate (see menu item "Settings"; see also help system of DOLFI)
- Restart the drive with "Serial disconnecting"
- Load parameters (DriveTop)

Notes

16 Attachment

16.1 Sizing relevant to supply and regeneration

Requirements

Note: When sizing the drive, you must check and observe the conditions relevant to supply and regeneration mentioned below.

Requirements for supply operation:

(Energy flux from supply system to installation)

$$P_{ZWD,system} \leq P_{ZWD,units}$$

$P_{ZWD,system}$: required DC bus continuous power of the system
 $P_{ZWD,units}$: allowed DC bus continuous power of the units

Fig. 16-1: DC bus continuous power

$$P_{ZWS,system} \leq P_{ZWS,units}$$

$P_{ZWS,system}$: required DC bus peak power of the system
 $P_{ZWS,units}$: allowed DC bus peak power of the units

Fig. 16-2: DC bus peak power

Requirements for regenerative operation:

(Energy flux from installation to DC bus)

$$P_{RD,system} \leq P_{RD,units}$$

$P_{RD,system}$: required continuous regenerative power of the system
 $P_{RD,units}$: allowed continuous regenerative power of the units

Fig. 16-3: Continuous regenerative power

$$P_{RS,system} \leq P_{RS,units}$$

$P_{RS,system}$: required peak regenerative power of the system
 $P_{RS,units}$: allowed peak regenerative power of the units

Fig. 16-4: Peak regenerative power

$$W_R,system \leq W_R,units$$

$W_R,system$: required regenerative power of the system
 $W_R,units$: allowed regenerative power of the units

Fig. 16-5: Regenerative power

Calculations with regard to the power and energy allowed on the device side

$$P_{ZWD, \text{Geräte}} = f * [n * P_{ZWD, DKC40} + k * P_{ZWD, DKC100} + l * P_{ZWD, DKC200} + m * P_{ZWD, BZM}]$$

$$P_{ZWS, \text{Geräte}} = f * [n * P_{ZWS, DKC40} + k * P_{ZWS, DKC100} + l * P_{ZWS, DKC200} + m * P_{ZWS, BZM}]$$

$$P_{RD, \text{Geräte}} = f * [n * P_{RD, DKC40} + k * P_{RD, DKC100} + l * P_{RD, DKC200} + m * P_{RD, BZM}]$$

$$P_{RS, \text{Geräte}} = f * [n * P_{RS, DKC40} + k * P_{RS, DKC100} + l * P_{RS, DKC200} + m * P_{RS, BZM}]$$

$$W_{R, \text{Geräte}} = f * [n * W_{R, MAX, DKC40} + k * W_{R, MAX, DKC100} + l * W_{R, MAX, DKC200} + m * W_{R, MAX, BZM}]$$

$P_{ZWD, \text{Geräte}}$:	allowed DC bus continuous power of the units
$P_{ZWD, DKC***}$:	allowed DC bus continuous power DKC (40A, 100A, 200A)
$P_{ZWD, BZM}$:	allowed DC bus continuous power BZM
$P_{ZWS, \text{Geräte}}$:	allowed DC bus peak power of the units
$P_{ZWS, DKC***}$:	allowed DC bus peak power DKC (40A, 100A, 200A)
$P_{ZWS, BZM}$:	allowed DC bus peak power BZM
$P_{RD, \text{Geräte}}$:	allowed continuous regenerative power of the units
$P_{RD, DKC***}$:	allowed continuous regenerative power DKC (40A, 100A, 200A)
$P_{RD, BZM}$:	allowed continuous regenerative power BZM
$P_{RS, \text{Geräte}}$:	allowed peak regenerative power of the units
$P_{RS, DKC***}$:	allowed peak regenerative power DKC (40A, 100A, 200A)
$P_{RS, BZM}$:	allowed peak regenerative power BZM
$W_{R, \text{Geräte}}$:	allowed regenerative power of the units
$W_{R, MAX, DKC***}$:	max. regenerative power in DKC (40A, 100A, 200A)
$W_{R, MAX, BZM}$:	max. regenerative power in BZM
$f = 1$:	for operation without DC bus connection
$f = 0,8$:	for operation with DC bus connection
n :	number of DKC-040 on the common DC bus
k :	number of DKC-100s on the common DC bus
l :	number of DKC-200s on the common DC bus
m :	number of BZMs on the common DC bus

Fig. 16-6: Power and energy allowed on the device side

Individual data see page 6-1: "Dimensions Auxiliary Bleeder Module BZM01.3" and following.

Calculations with regard to the power and energy resulting on the installation side

$$P_{ZWD, Anlage} = \frac{M_1 * \omega_1 * t_1 + M_2 * \omega_2 * t_2 + \dots + M_i * \omega_i * t_i * \frac{1}{\eta}}{t_z} \qquad \omega = 2 * \pi * n_i$$

$$P_{ZWS, Anlage} = M_{max} * \omega_{max} * \frac{1}{\eta} \text{ (acceleration)}$$

$$P_{RD, Anlage} = \frac{\sum W_{ROT} + \sum W_{POT} * \eta}{t_z} \qquad W_{ROT} = \frac{(J_{LAST} + J_M)}{2} * \left(n * \frac{2 * \pi}{60}\right)^2 * z_{DEC}$$

$$W_{POT} = m_{LAST} * g * h * z_{AB}$$

$$P_{RS, Anlage} = M_{max} * \omega_{max} * \eta \text{ (deceleration)}$$

$$W_R, Anlage = (\sum W_{ROT} + \sum W_{POT}) * \eta$$

- P_{ZWD,Anlage}: resulting DC bus continuous power of the system
- P_{ZWS,Anlage}: resulting DC bus peak power of the system
- P_{RD,Anlage}: resulting continuous regenerative power of the system
- P_{RS,Anlage}: resulting peak regenerative power of the system
- W_{R,Anlage}: resulting regenerative power of the system
- W_{ROT}: rotary energy
- W_{POT}: potential energy
- t_z: cycle time
- t_i: time of influence
- J_{LAST}: load inertia
- J_M: motor inertia
- m_{LAST}: load weight
- g: 9,81 ms²
- h: lowering distance in meters
- n: motor speed
- z_{AB}: number of drops per cycle
- z_{DEC}: number of braking actions per cycle
- M_{max}: maximum torque
- M_i: torque at the motor shaft
- n_{max}: max. motor speed
- n_i: operating motor speed
- η: efficiency in the drive line (converter, motor, gearing)

Fig. 16-7: Power and energy resulting on the installation side

Calculation with regard to reduction of resulting power dissipation

CZM01.3

When braking the drive, the rotary energy present in the mechanics is fed back to the DC bus of the DKC in the form of regenerated energy. It can

- Be reduced to dissipated heat via the braking resistor integrated into the DKC or an auxiliary braking resistor can additionally be built in

- or -

- It can be stored as energy in the DKC with connected auxiliary capacitance module and then re-used for acceleration procedures. This reduces the heat in the control cabinet and lowers energy consumption.

For a successful implementation and an avoidance of unnecessary heat loss in the control cabinet, it applies:

$$W_{R, Anlage} \leq W_{ZW, DKC} + W_{ZW, CZM}$$

$W_{R, Anlage}$: required regenerative power of the system

W_{ZW} : storable energy of the DC bus capacitors

Fig. 16-8: Condition to avoid power dissipation from the regenerative power

Calculating the allowed continuous braking resistor and DC bus power

By connecting the DC bus connections of several DKC and BZM drive controllers the regenerative power and regenerative continuous power resulting in the common DC bus is evenly distributed to all ECODRIVE03 components with a braking resistor.

The distribution to the components involved is realized takes place with a high balancing factor.

For central supply and group supply with DC bus connection

$$P_{BD, \text{Geräte}} = \sum (P_{BD, DKC} + P_{BD, BZM}) * 0,8$$

$P_{BD, \text{Geräte}}$: continuous braking resistor power that can be consumed in continuous operation by all devices on the common DC bus, in kW

$P_{BD, DKC}$: continuous braking resistor power that the drive controller can consume in continuous operation, in kW

$P_{BD, BZM}$: continuous braking resistor power that the auxiliary braking resistor module can consume in continuous operation, in kW

Fig. 16-9: Continuous braking resistor power of all devices on the common DC bus

$$P_{ZW, \text{Geräte}} = \sum P_{ZW} * 0,8$$

$P_{ZW, \text{Geräte}}$: available continuous DC bus power on the common DC bus, in kW

P_{ZW} : continuous DC bus power of the single devices in kW

Fig. 16-10: Continuous DC bus power of all devices on the common DC bus

For single source supply and group supply without DC bus connection

See page 4-6.

16.2 Use of the connections for looping through the control voltage

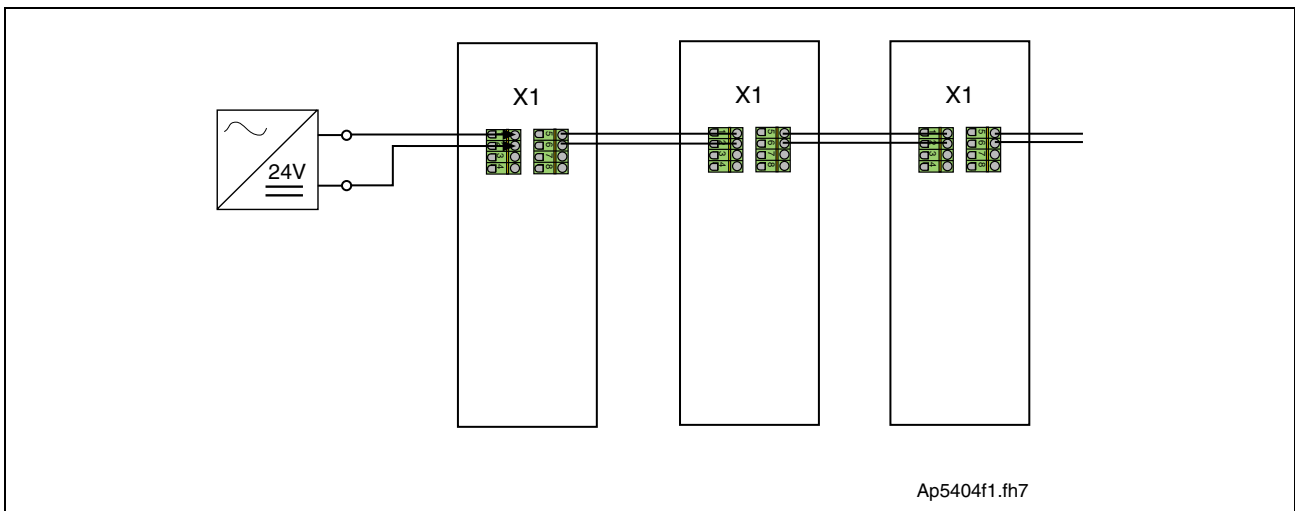

Fig. 16-11: Looping through the control voltage

Calculation for 3 DKC02.3-040 drive controllers:

$$I_D = 3 \times \frac{P_{N3}}{U_{N3}} = 3 \times \frac{19 \text{ W}}{24 \text{ V}} = 2,31 \text{ A}$$

Fig. 16-12: Continuous current I_D

$$I_E = 3 \times I_{EIN3} = 3 \times 4 \text{ A} = 12 \text{ A}$$

Fig. 16-13: Charging current I_E

Duration of the charging current peak according to figure "Amplitude of the DKC control voltage charging current at startup, to selecting power source" on page 4-15: approx. 12 ms

Note: In the case of the DKC**.3-016-7-FW, the control voltage cannot be looped through.

16.3 Control Cabinet Construction with Recommendations for EMC and Cooling

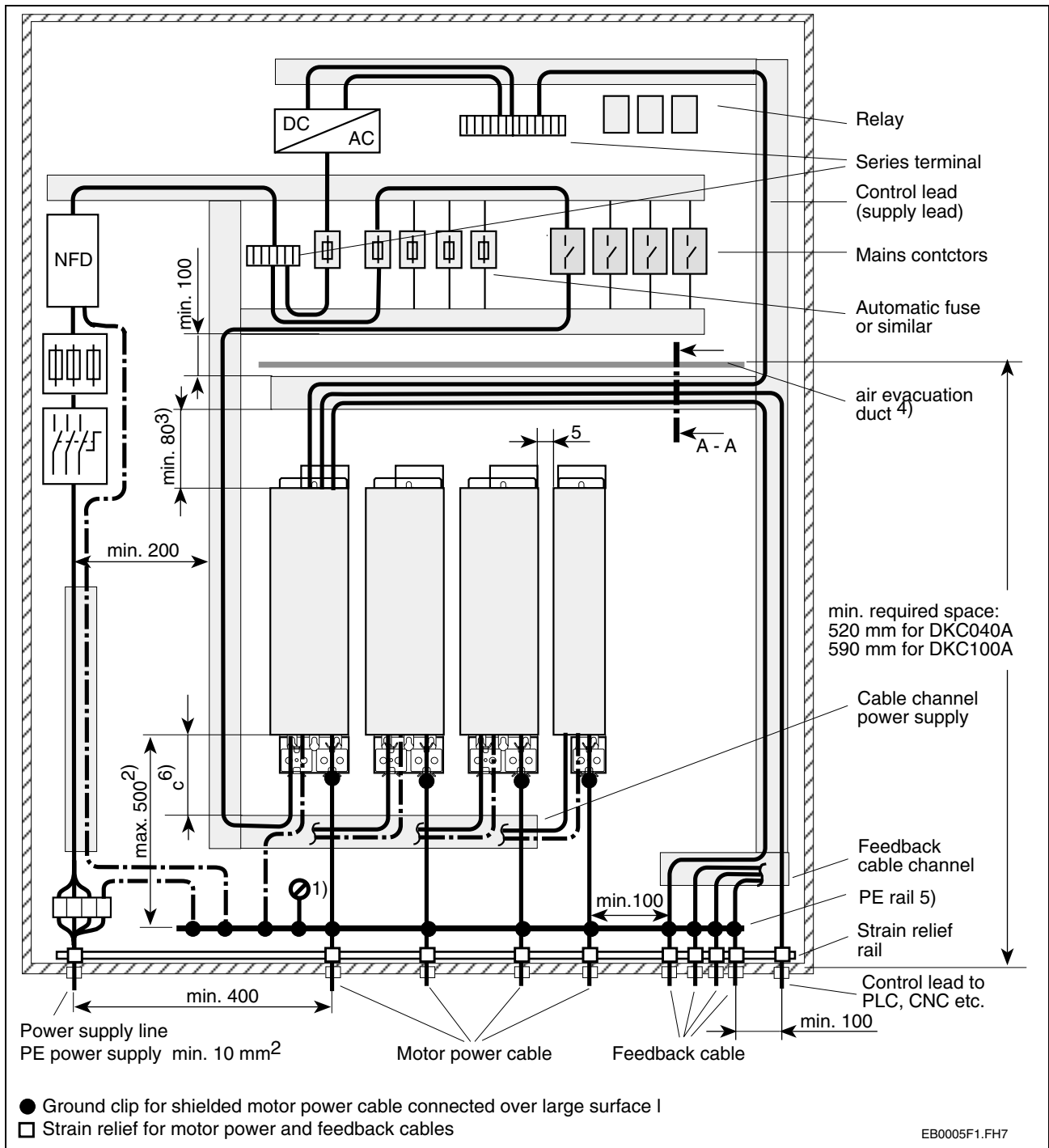

Fig. 16-14: Recommendations on constructing the control cabinet

- 1) PE rails linked over a large surface with the bare metal of the mounting panel.
- 2) Given a distance less than 500 mm between the point of clamping of the motor cable and the PE rail, the motor cable does not have to run through the cable channel on the mounting panel.

- 3) This dimension depends on the projected continuous braking resistor power. See 12-6 "Distances"
A DKC100A or BZM unit, under full load needs greater distances, up to 300mm, or an air evacuation duct. A DKC100A with connection to connector strips X9/X10/X11 needs a minimum distance of 150 mm. For DKC 040 As, 80 mm is generally acceptable.
- 4) Depending on air ducts or cabinet cooling method, it is advisable to mount an air evacuation duct, see section **A - A** in Fig. 16-14:
Recommendations on constructing the control , Fig. 16-15:
Wall cooling unit in the control cabinet door and Fig. 16-16:
Mounting the cooling unit onto top.
An air evacuation duct is always advisable with DKC100 or BZMs with high continuous braking resistor power.
- 5) The PE rail must be mounted directly to the strain relief track on the control cabinet leadthrough of the motor power cable.
- 6) Distance c see page 12-6 "Distances"

Sectional Drawing for Developing an Optimum Control Cabinet

The depth of the air evacuation duct depends on the size of the control cabinet.

ECODRIVE has been designed for a minimum control cabinet depth of 300 mm.

This offers several options on conducting air out of the cabinet.

Wall cooling unit in the control cabinet door

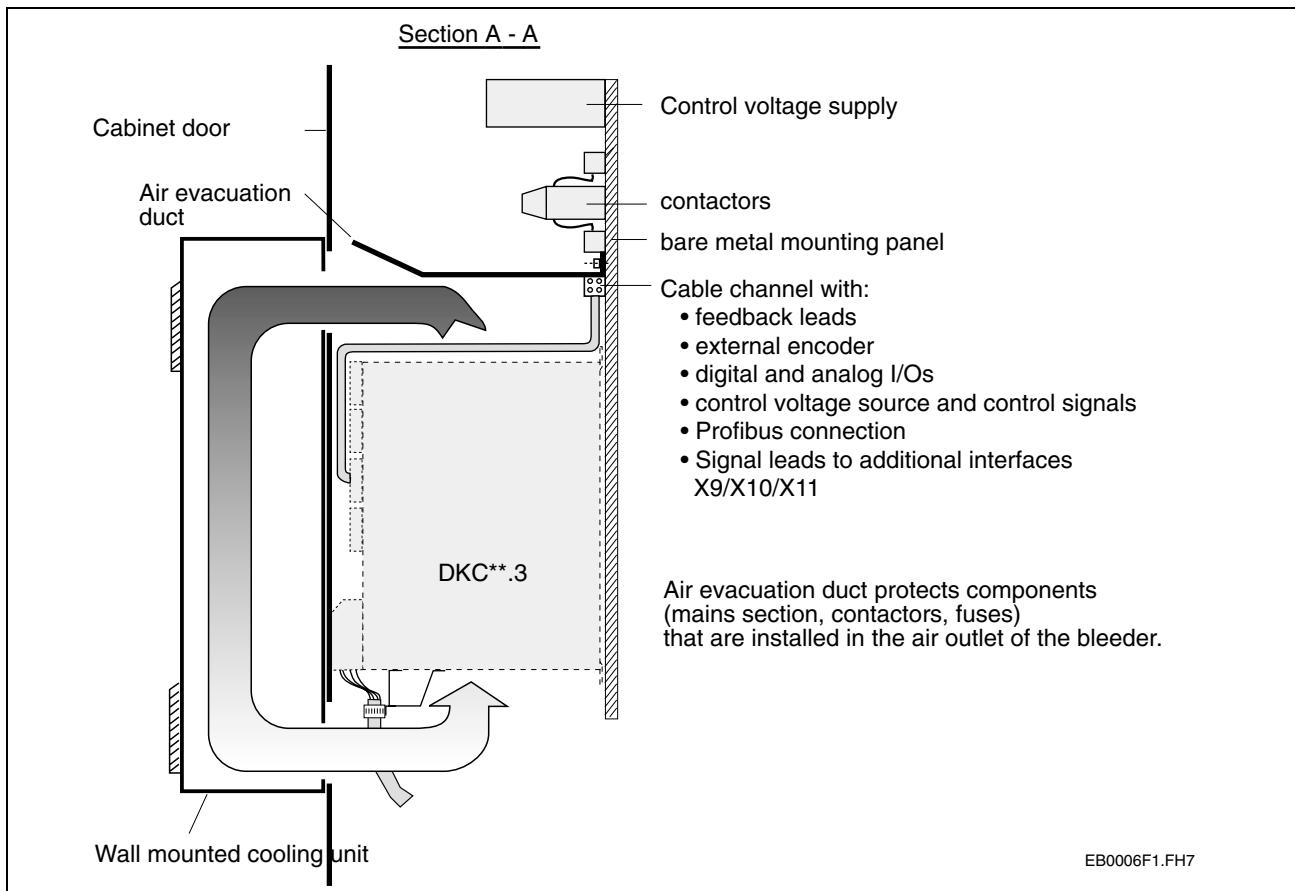

Fig. 16-15: Wall cooling unit in the control cabinet door

Mounting the cooling unit onto top

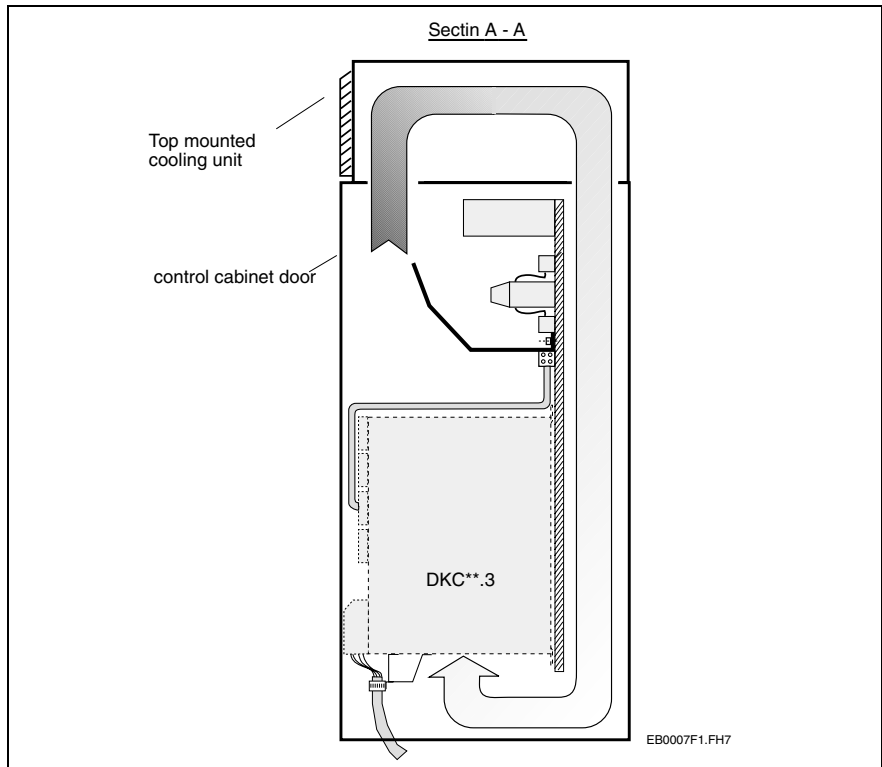

Fig. 16-16: Mounting the cooling unit onto top

16.4 Wire routing and wiring of the drive controller

DKC**.3-016 control connections

View of DKC02.3-016

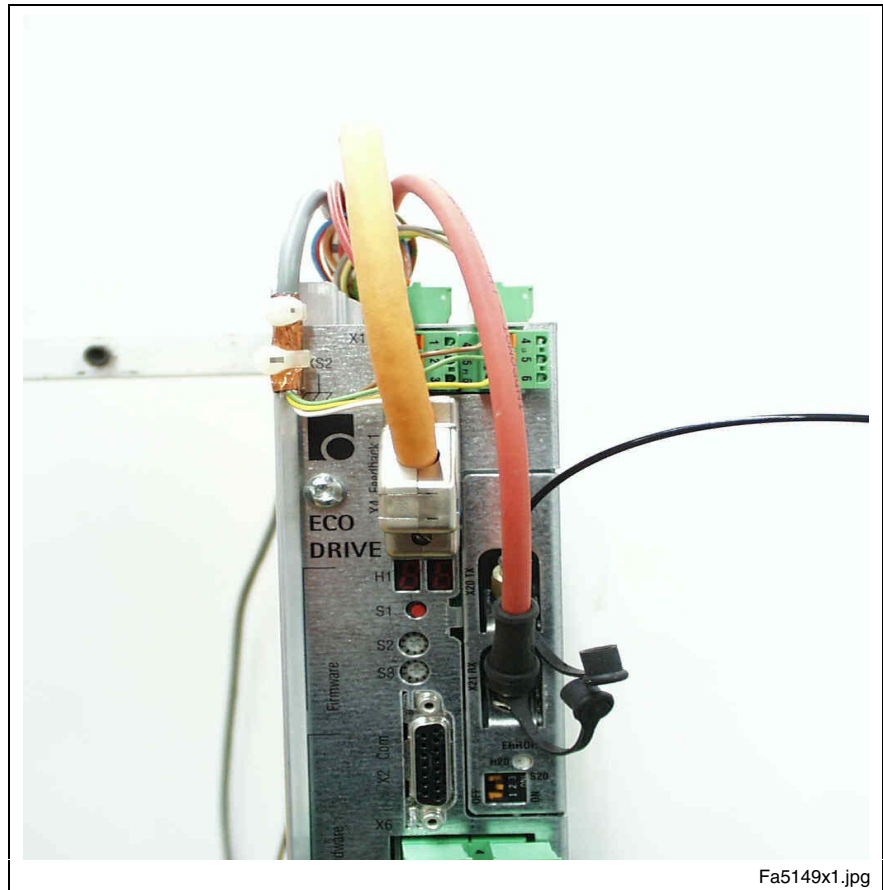

Fig. 16-17: View with SERCOS interface

View of DKC03.3-016

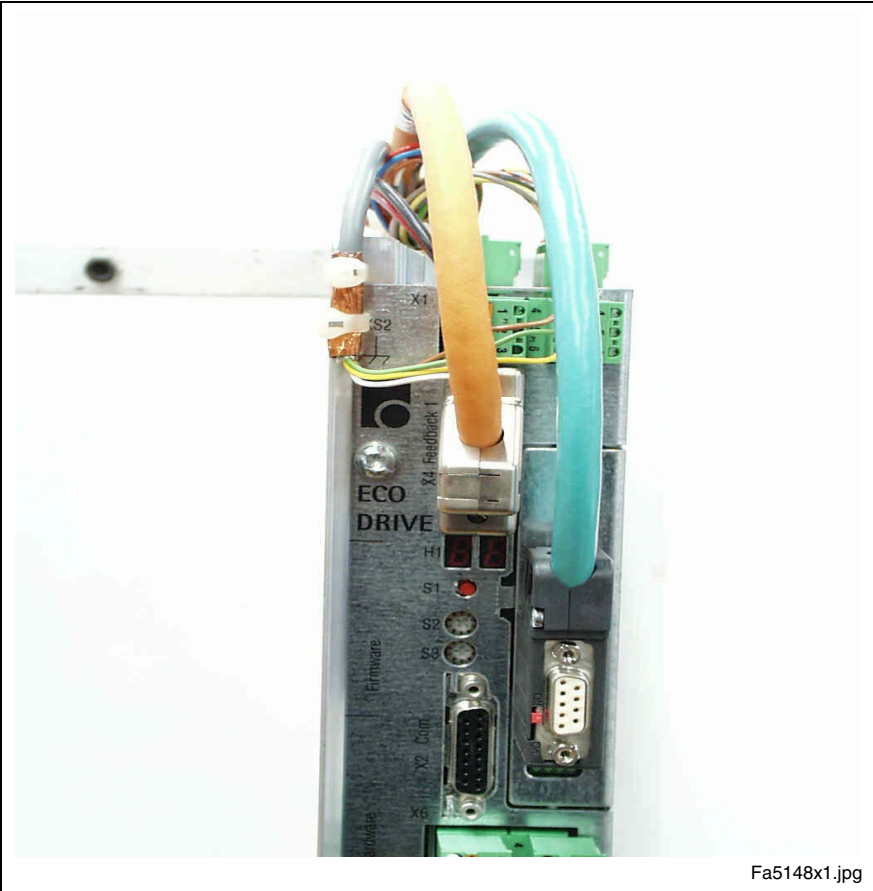

Fig. 16-18: View with Profibus-DP Interface

View of DKC21.3-016

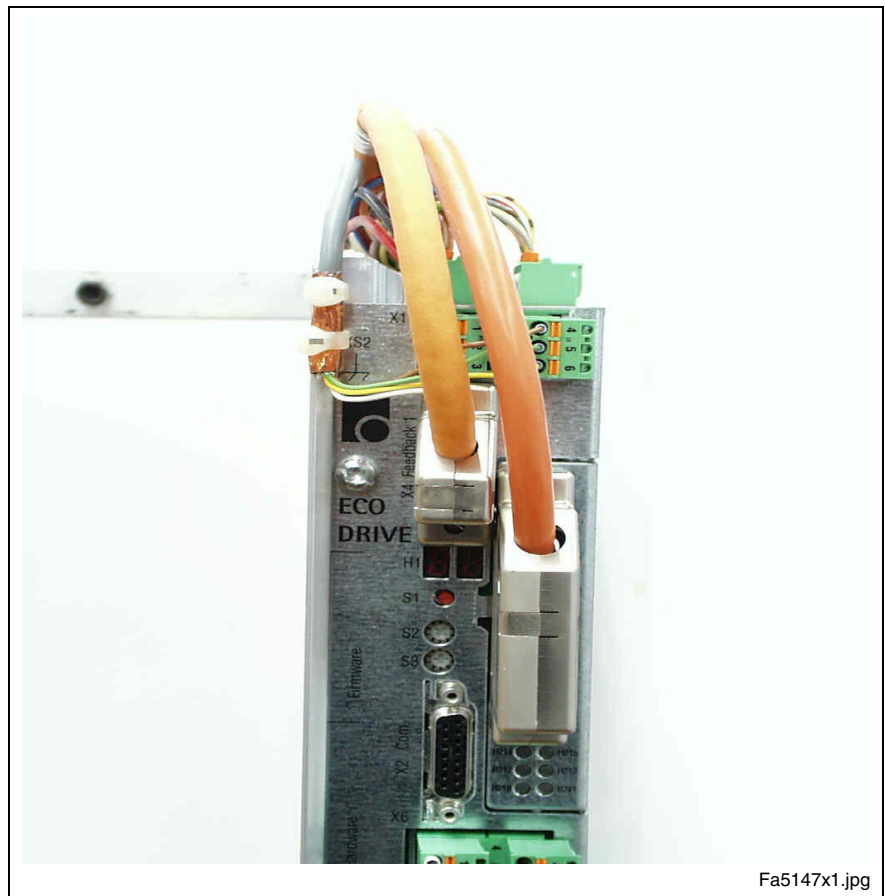

Fig. 16-19: View with Parallel Interface 2

Detail view X1, X3, X10, XS2 and XS3 with cable shield connection

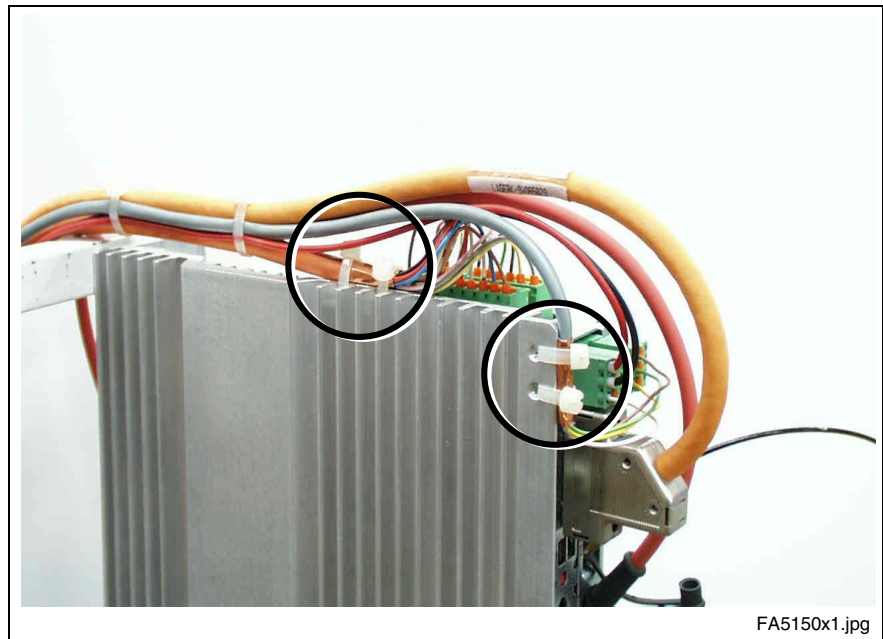

Fig. 16-20: Detail view X1, X3, X10, XS2 and XS3

- Fasten the cable shields with 2 cable ties each at XS2 or XS3.

Control connection DKC**.3-040/100/200

Note: Representing all DKC**.3 – drive controller devices the following construction examples are based on the device DKC**.3-040-7.

View with contact protection

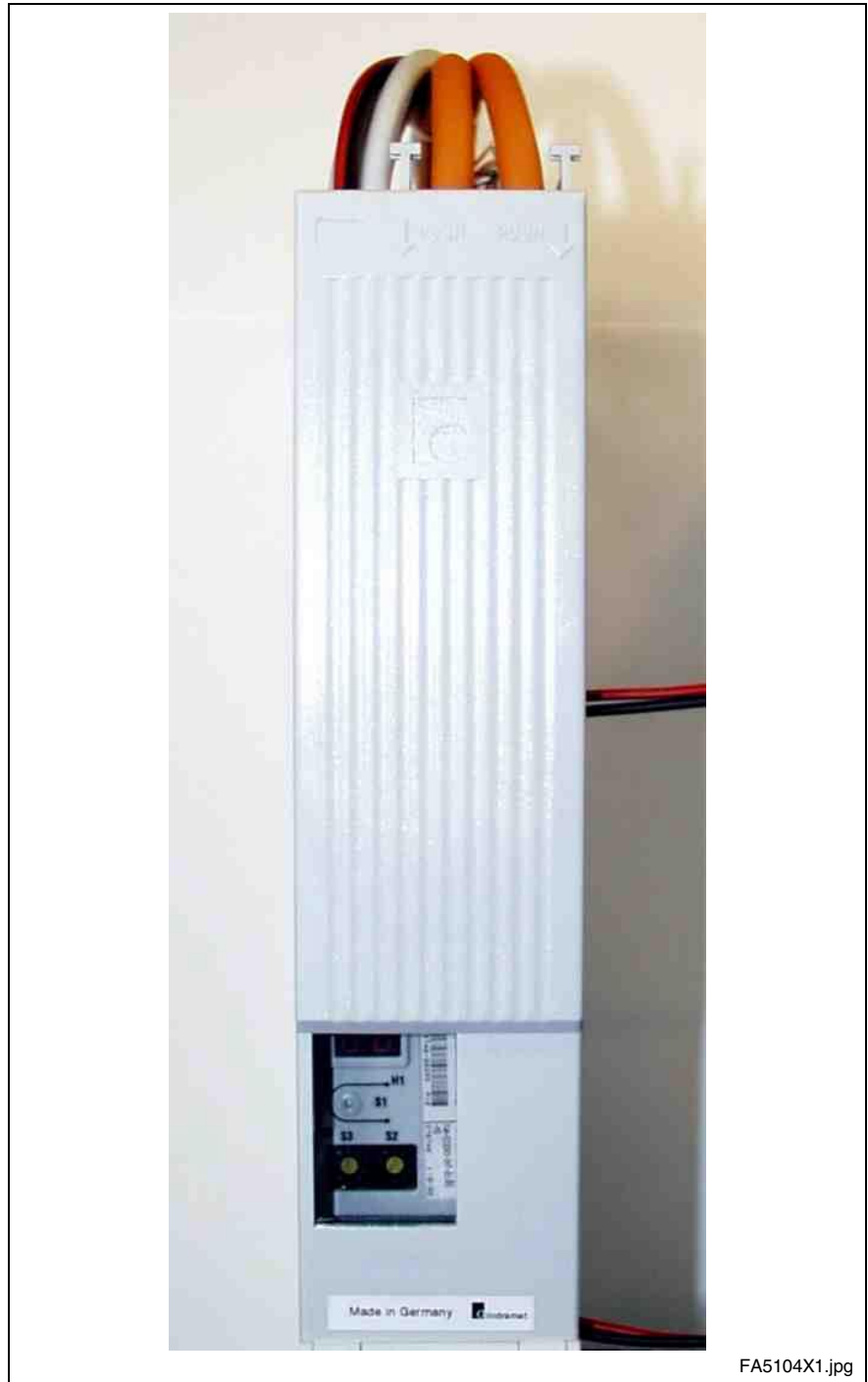
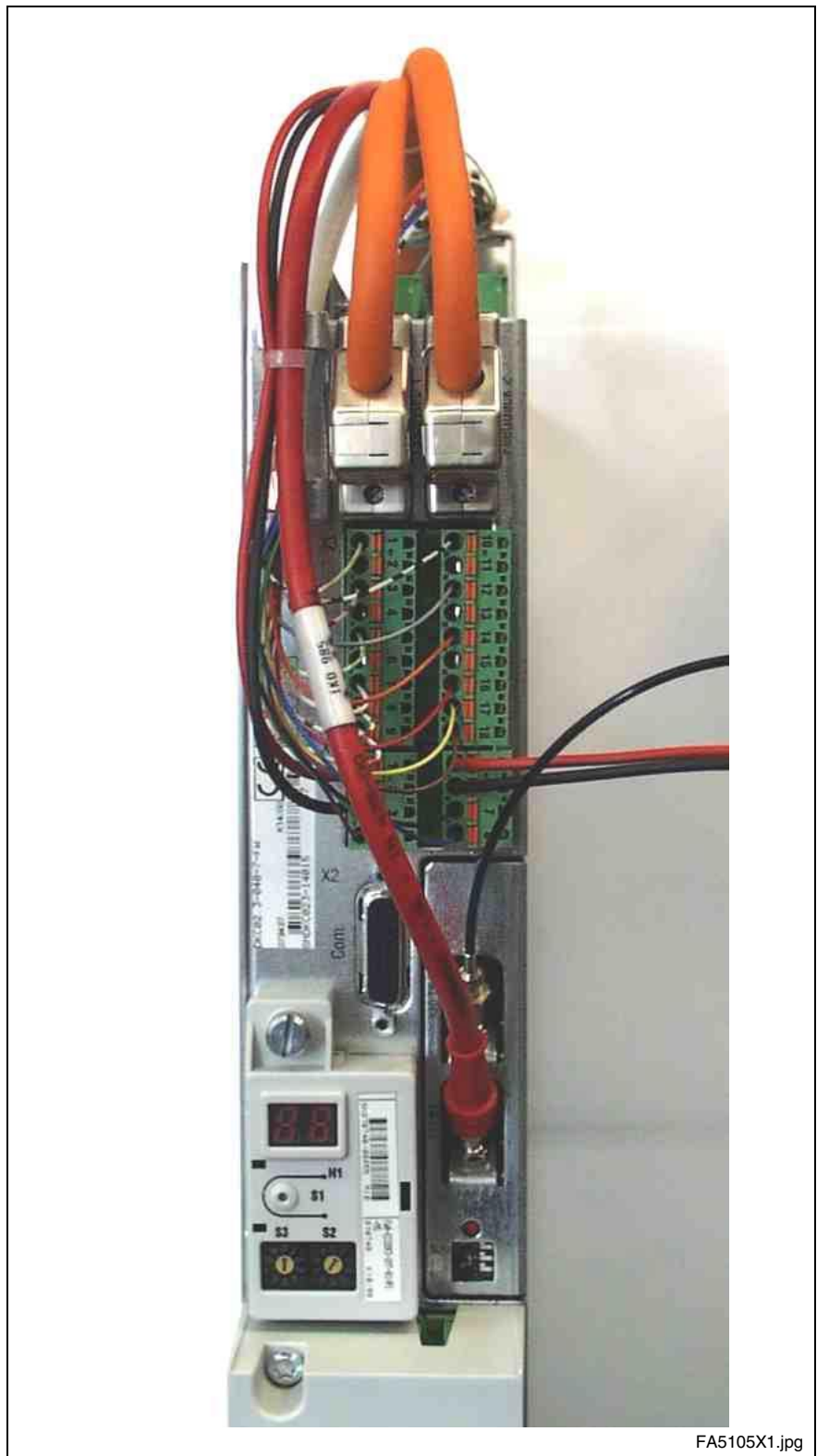

Fig. 16-21: View with contact protection

View of DKC02.3-040-7



FA5105X1.jpg

Fig. 16-22: View with SERCOS interface

View of DKC03.3-040-7

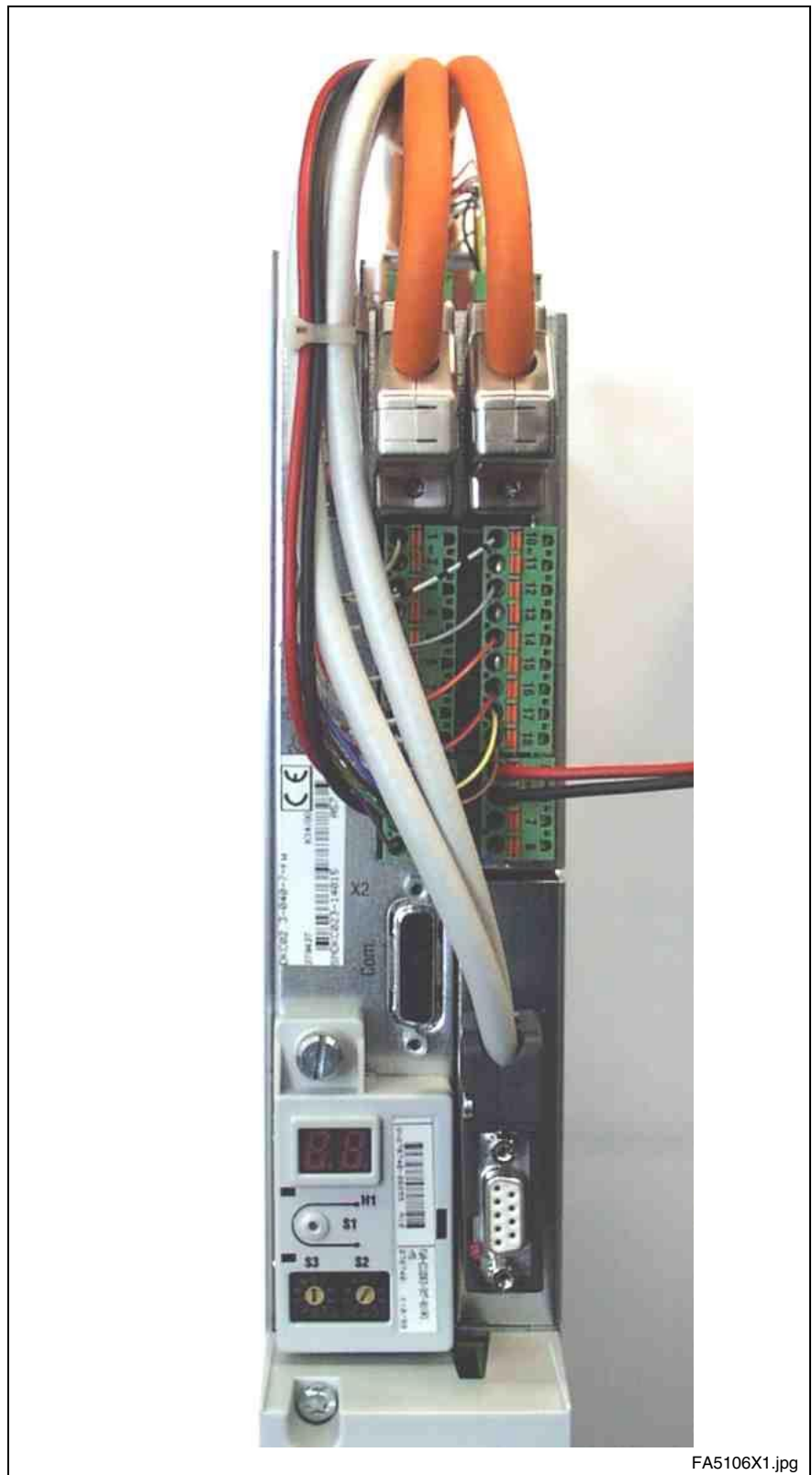

Fig. 16-23: View with Profibus-DP Interface

View of DKC21.3-040-7

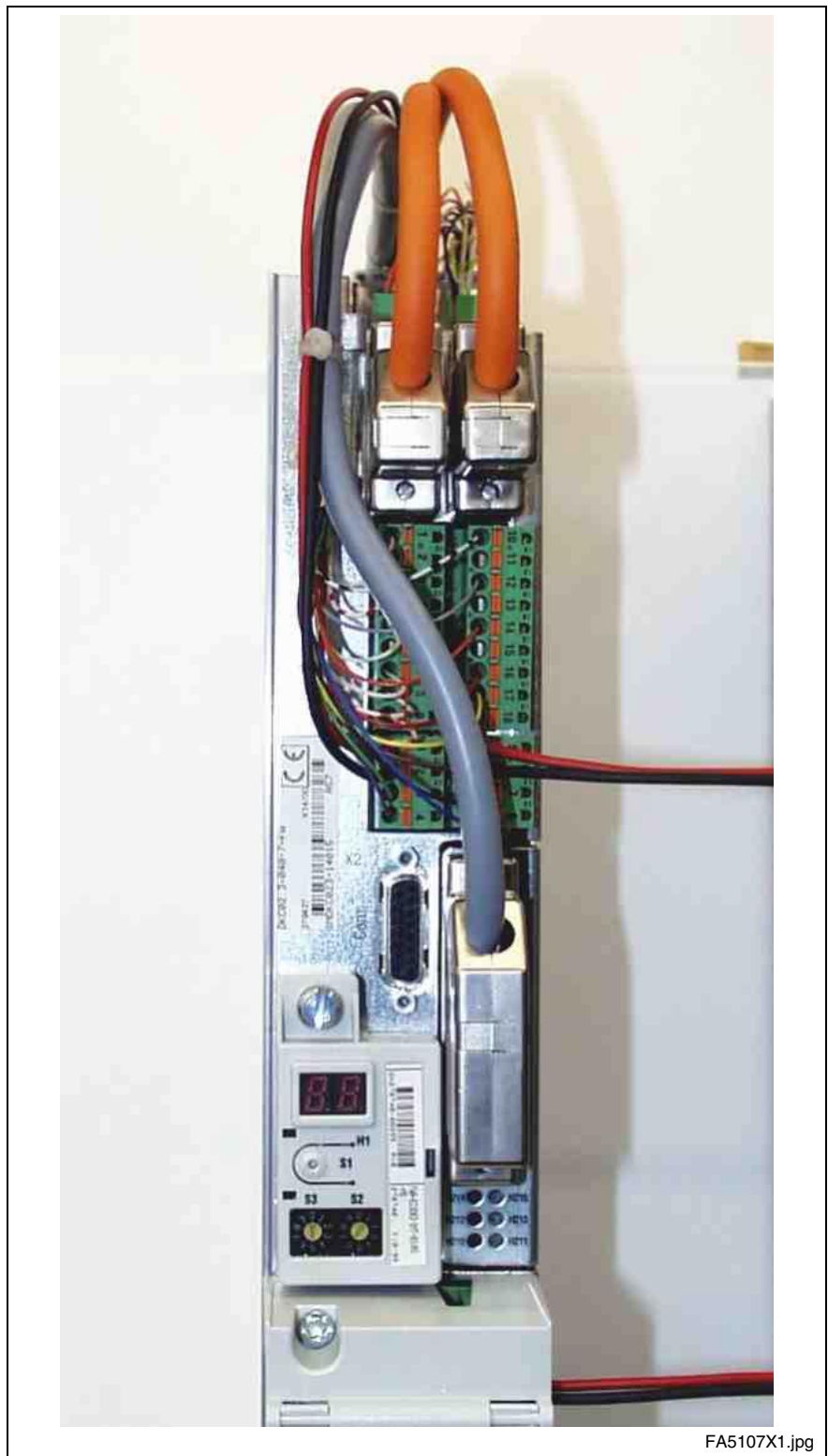

Fig. 16-24: View with Parallel Interface 2

Detail view X4, X8 and XS2 with cable shield connection

Fig. 16-25: Detail view X4, X8, XS2

Detail view X9, X10, X11 and XS3 with cable shield connection

Fig. 16-26: Detail view X9, X10, X11, XS3

Power connection

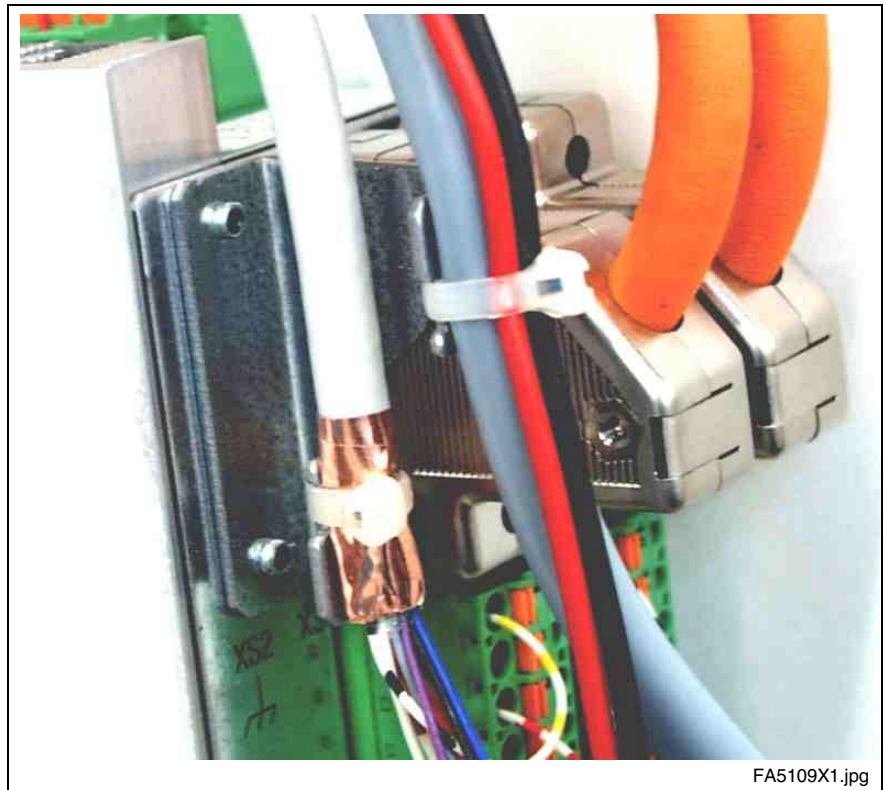
Connection of motor and mains cable DKC** .3-016-7

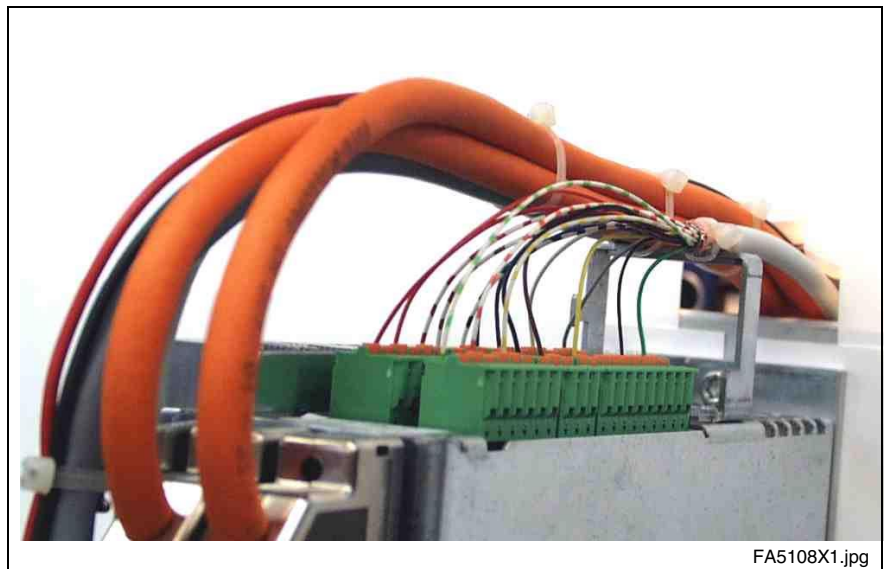
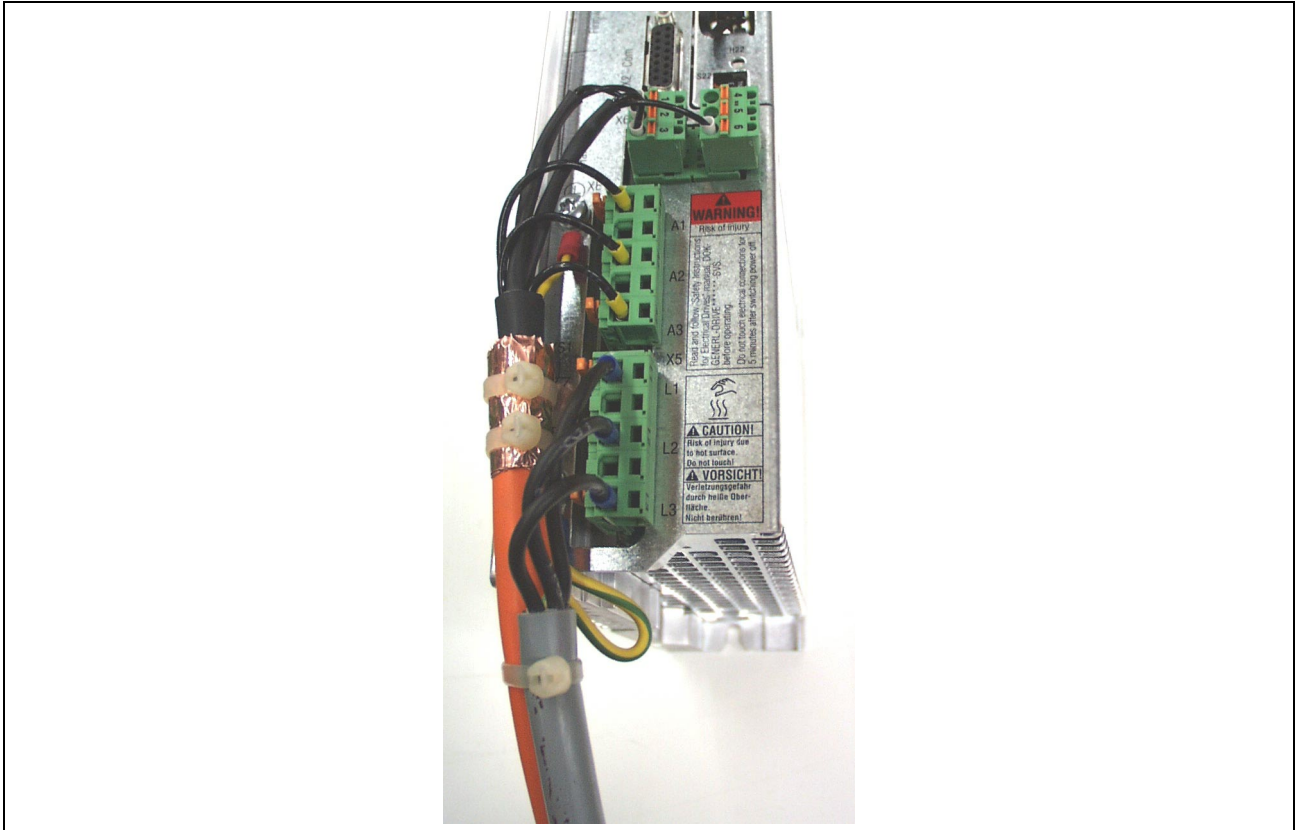

Fig. 16-27: Connection of motor and mains cable

- Fasten the motor cable with two cable ties to the shield connection at the heatsink.
- Fasten the motor cable and the mains cable in the control cabinet as near as possible to the drive controller, because the two cable ties do not serve as strain relief.
- Always place the direct connectors for motor and mains connection on the drive controller in such a way that the barbs lock into place.

View with contact protection DKC**.3-040-7



Fig. 16-28: View with contact protection

Note: SUP-E01-DKC**.3 as of hardware index A65 is integrated in device DKC**.3-040-7.

View X5, X6, XE1, XE2 and XS1 with cable shield connection on DKC.3-040-7**

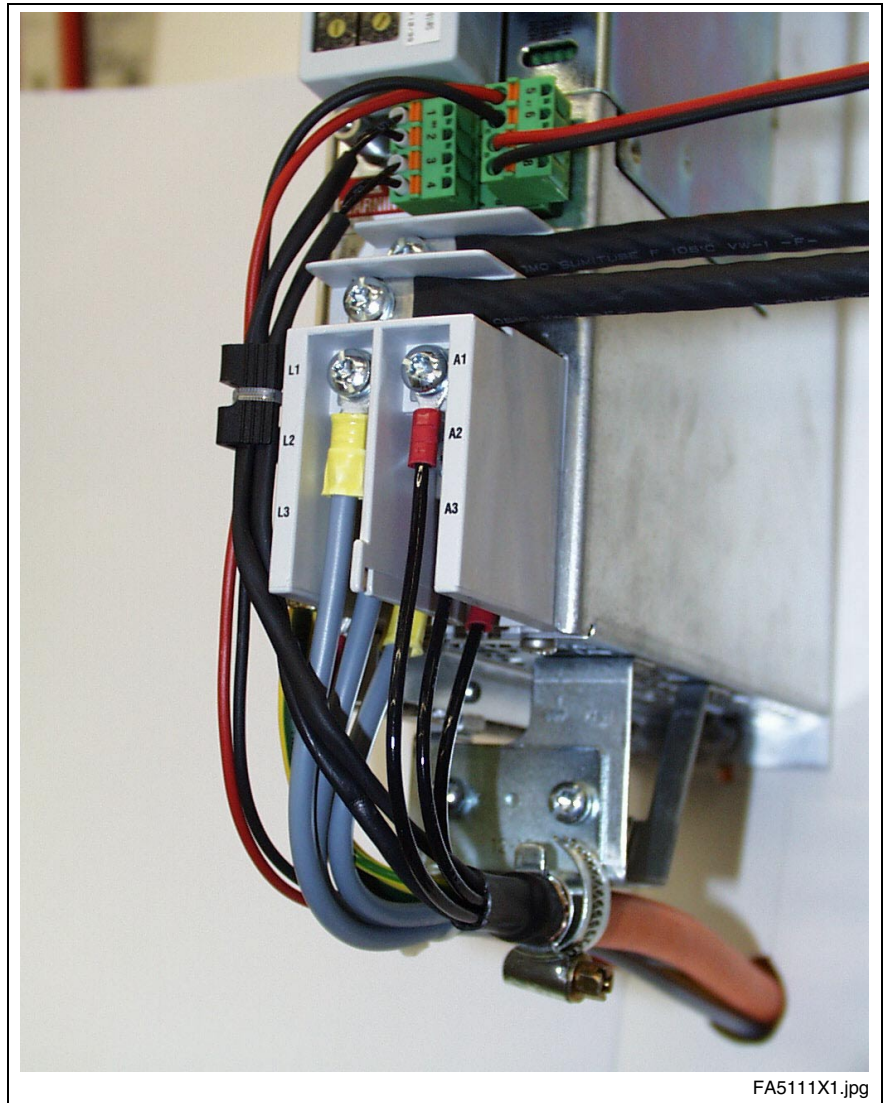

FA5111X1.jpg

Fig. 16-29: View X5, X6, XE1, XE2 and XS1

View with contact protection DKC**.3-100-7



Fig. 16-30: View with contact protection

View X5, X6, XE1, XE2 and XS1 with cable shield connection on DKC.3-100-7**

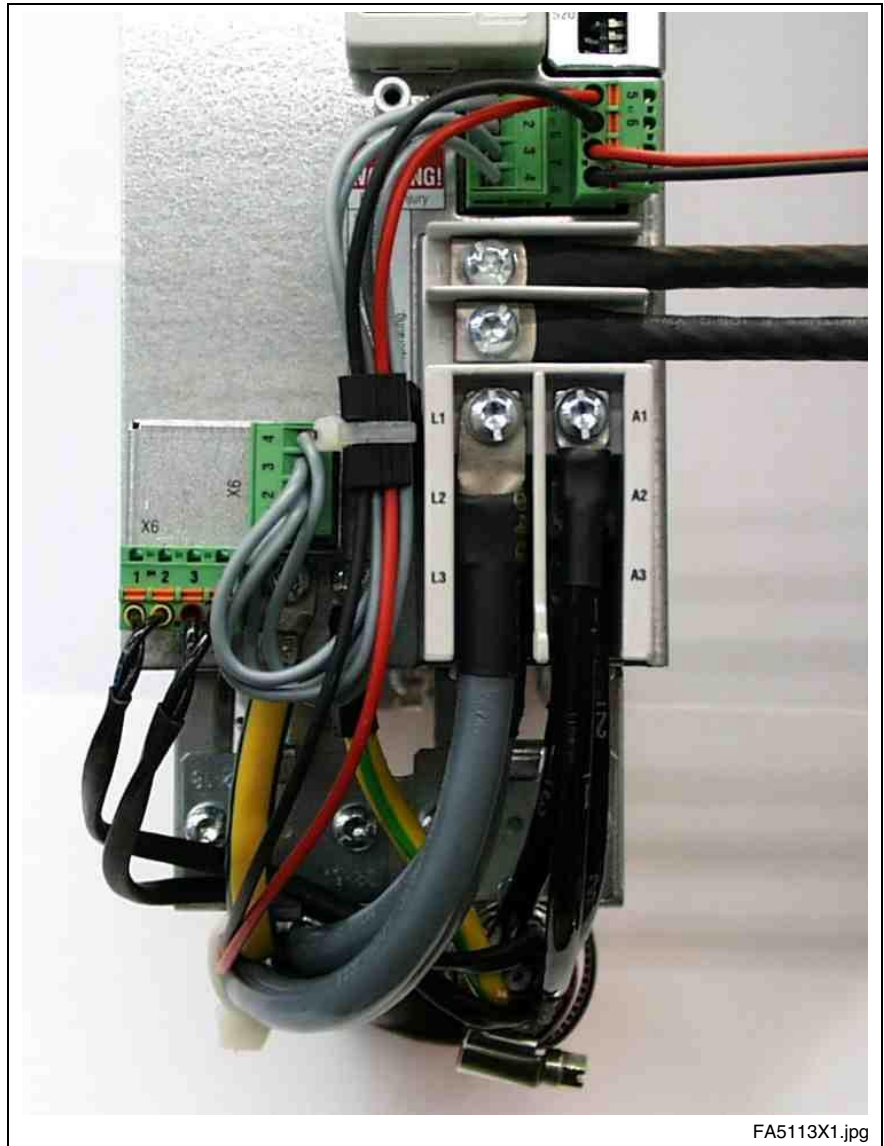

Fig. 16-31: View X5, X6, XE1, XE2 and XS1

View with contact protection DKC**.3-200-7



FA5114X1.jpg

Fig. 16-32: View with contact protection

Note: Two bridges may be cut off to simplify the seating of the contact protection when using circular cross sections $\geq 16 \text{ mm}^2$.

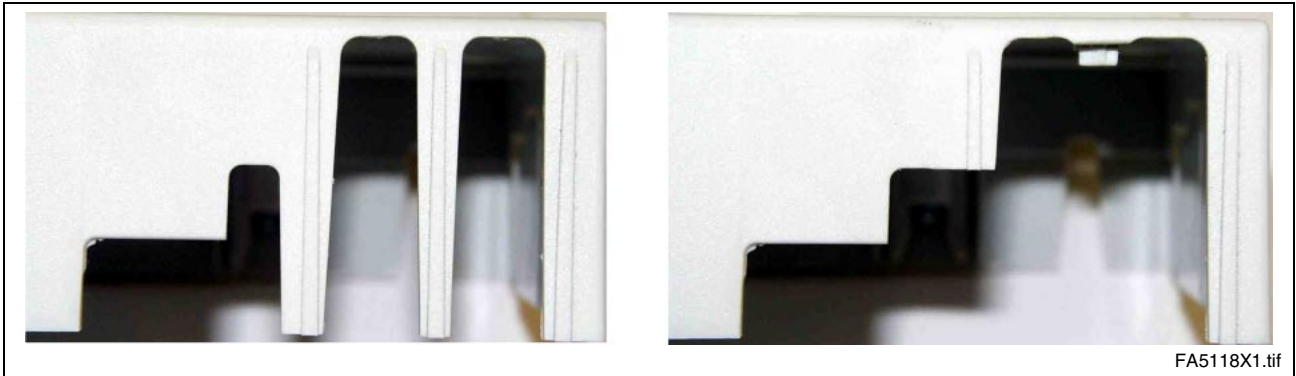

FA5118X1.tif

Fig. 16-33: Contact protection with and without bridges

View X5, X6, X12, XE1, XE2 and XS1 with cable shield connection on DKC.3-200-7**

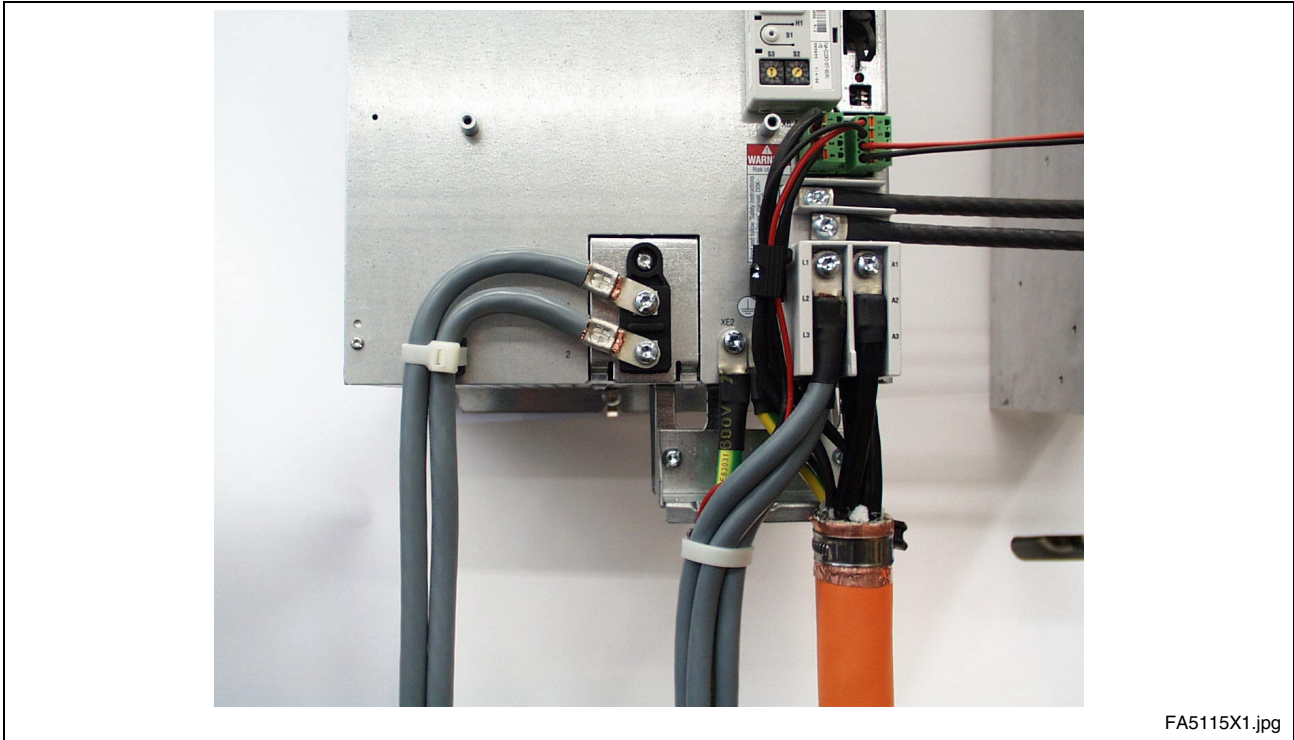

Fig. 16-34: View X5, X6, X12, X100, XE1, XE2 and XS1

RS485 - Connector

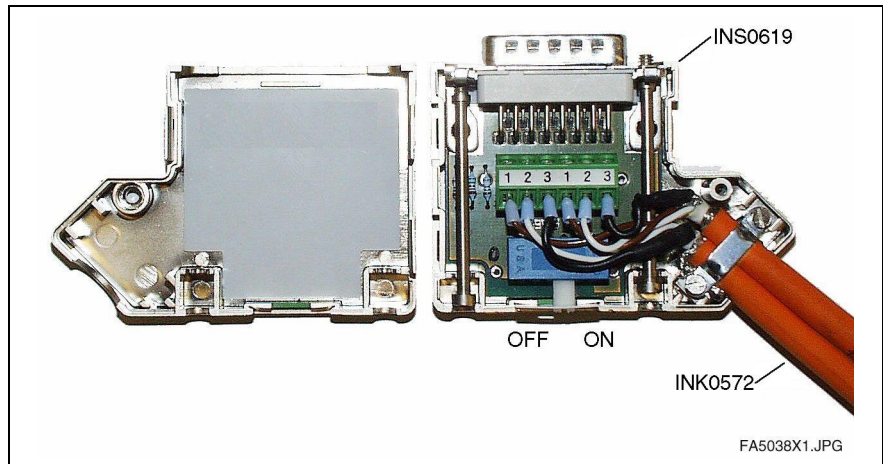

Fig. 16-35: Connecting the RS485 - Connectors

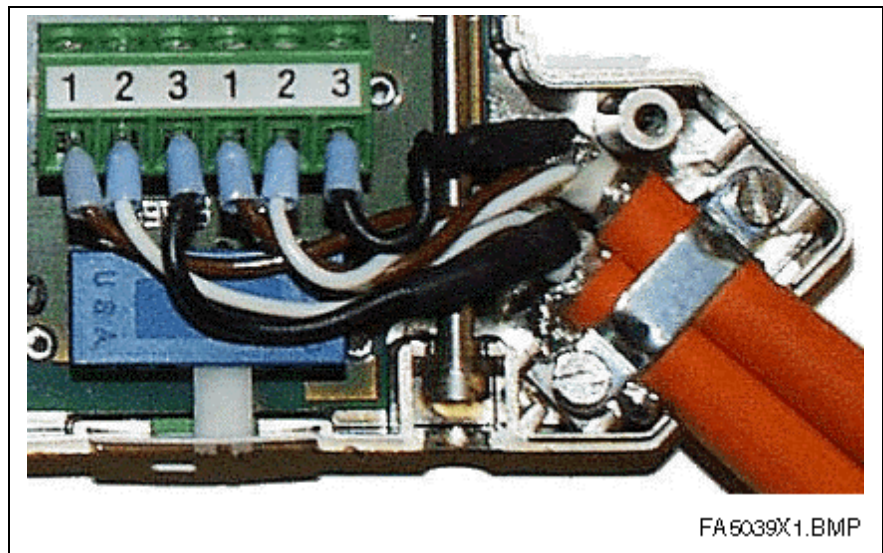

Fig. 16-36: Connecting the RS485 - Connectors

16.5 What is needed to prepare to start-up

To start up an ECODRIVE drive system, the following is needed:

- Measuring equipment
- PC
- Linking cables (PC-drive controller)

Measuring devices

To be able to read off torque, current and velocity in the form of analog signals at the analog outputs, the following measuring equipment is needed:

- Multimeter to take voltage readings (suffices with a serial start-up)
- Oscilloscope or plotter (only needed to record signal paths when commissioning a prototype)

Personal computer (PC)

The PC is needed to program, parameterize and diagnose when starting up and servicing.

Hardware requirements:

- IBM compatible
- min. 80486 microprocessor (Pentium 166 or higher recommended)
- at least 16 MB RAM memory
- hard drive with at least 80 MB available memory
- CD-ROM drive
- A free serial RS232 interface on the PC (COM 1 or COM 2)

Software pre-requisites:

- Windows 95/98, NT4.0, 2000, ME
- DriveTop start-up program

Link cables (PC-drive controller)

DKC**.3-040/100/200: See page 4-49 X2, Serial Interface resp.
DKC**.3-016: See page 5-23 X2, Serial Interface

16.6 Command Value Box Connection

Command Value Box To run the drive, a command value must be set at the relevant interface (positioning, analog or step motor interface).

For test purposes, a velocity command value can be set with the help of a command value box via the analog interface.

The following illustrates a command value box circuit recommendation.

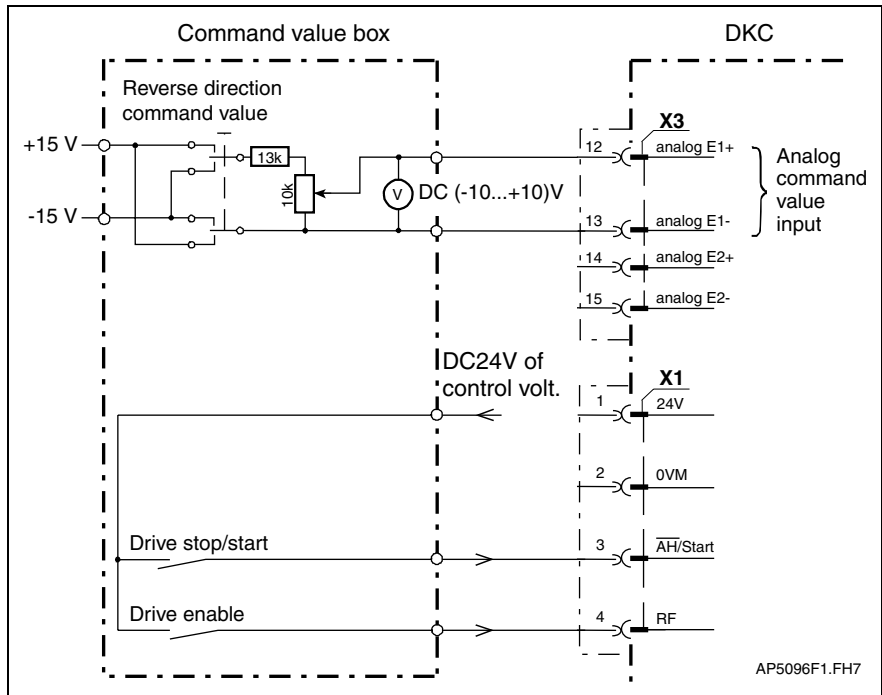

Fig. 16-37: Command value box circuit recommendation for connecting an analog interface

Note: The analog input (not present on DKC**.3-016) used has to be parameterized. See firmware functional description.

16.7 Signal Sequence DKC**.3

Recommended Switching On Sequence

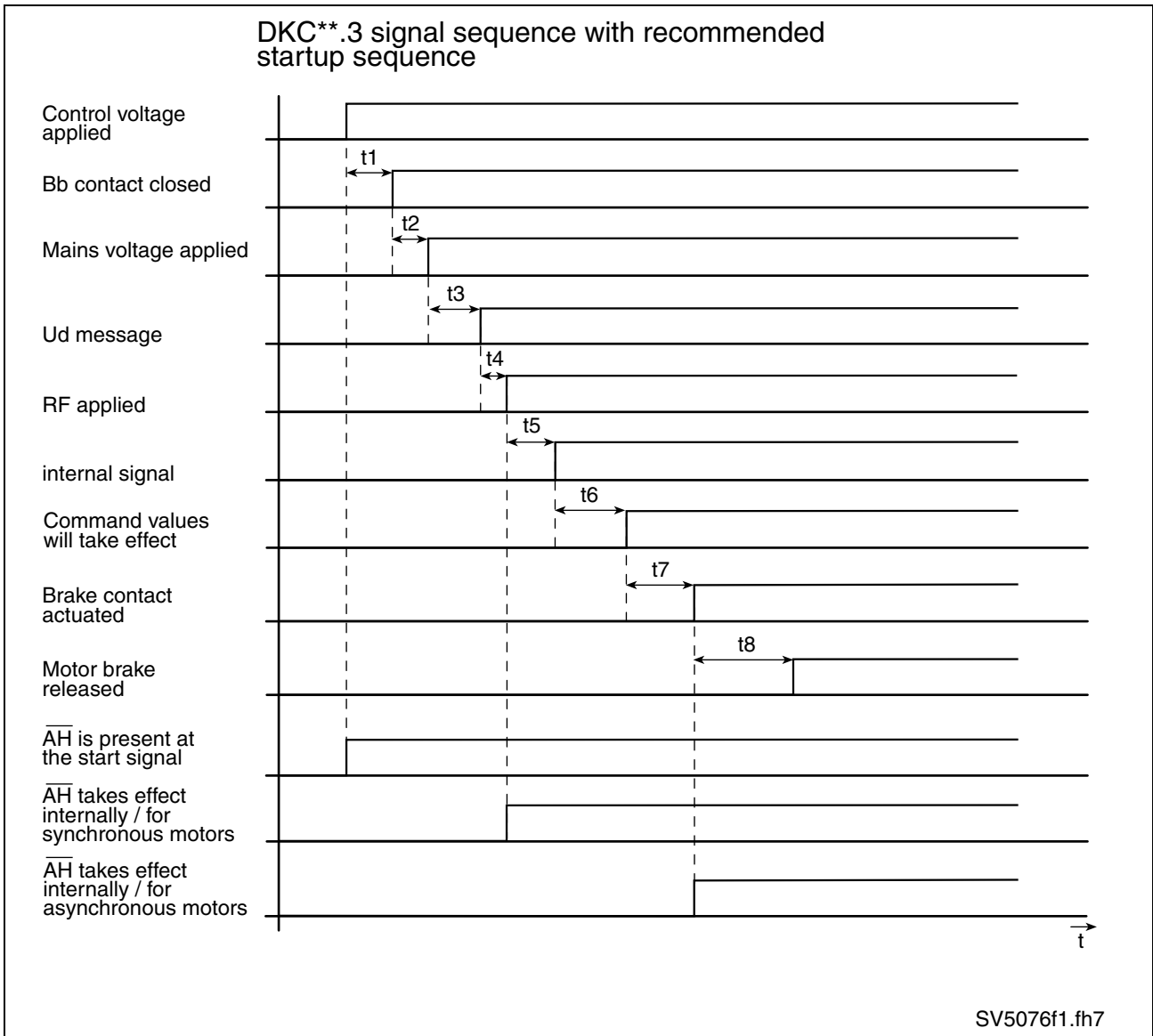

Fig. 16-38: Recommended switching on sequence

- t1: Depends on functions and configuration.
- t2: Made up of "Slow operation of mains contactor K1" and "PLC times".
- t3: See page 4-55: "Digital outputs (ready, warning and UD-message)".
- t4: Apply RF after signal U_D -Signal.
- t5: Internal delay time 8 ms.
- t6: 300 ms due to field built up in asynchronous motors, not applicable to synchronous motors.
- t7: Internal delay time due to brake relay:
330 ms with asynchronous
30 ms with synchronous motors
- t8: Separation time of brake used, listed in relevant motor project planning manual.

Explanation of Chronological Sequence

"Control voltage applied"
DC24V – supply at X1

"Bb contact closed"
Bb contact in DKC**.3 on X1

"Mains voltage applied"
Power supply at X5,
Start of DC bus charge procedure

" U_d - Signal"
Signal output at X3
(not for DKC**.3-016)

"RF applied"
Signal drive enable applied by user.

"Actual brake contact"
Brake contact in DKC**.3 on X6 is triggered.
Brake contact parameterized as N/C or N/O (see firmware functional description)

"Motor brake released"
Brake controlled via motor contact has been released.

" \overline{AH} applied"
Signal \overline{AH} (start signal at X1 (see firmware functional description)).

" \overline{AH} is working internally"
Internal signal sequence depends on motor used.

Recommended Off Sequence

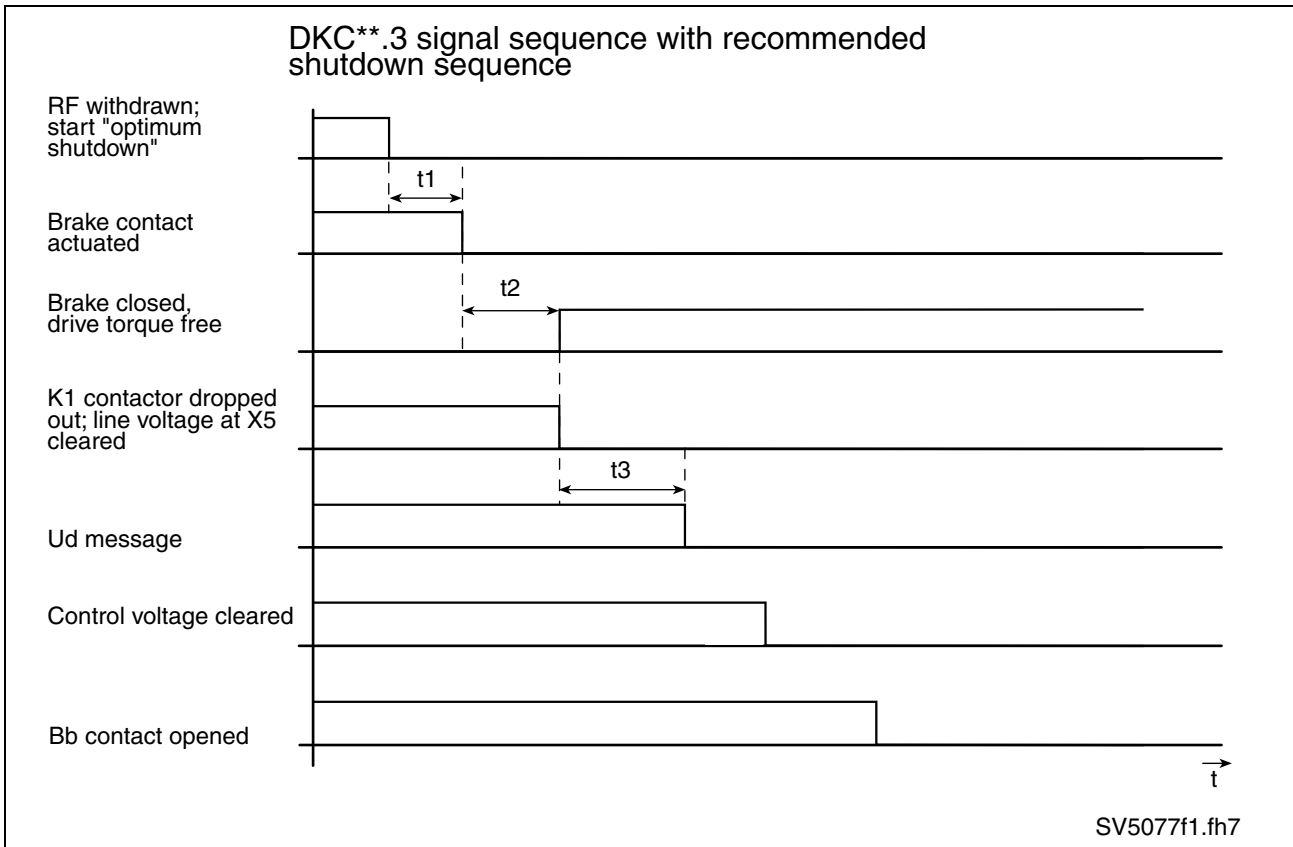

Fig. 16-39: Recommended off sequence

- t1: Brake time of drive
Maximum value parameterizable (see firmware functional description).
- t2: (see firmware functional description)
Brake delay time parameterizable with link time of brake (see relevant motor project manual), cannot be parameterized in MKDs and MHDs, fixed at 150 ms
- t3: Can be shortened by activating DC bus dynamic brake.

Explanation of Chronological Sequence

"RF removed"; start "Best possible standstill"
with removal of RF signal at X1 the recommended off sequence starts and "best possible standstill" (see firmware function description).

"Brake contact actuated":
Brake contact in DKC**.3 actuated at X6,
Brake contact parameterizable as N/C or N/O contact (see firmware functional description)

"Brake closed":
brake connected via brake contact is closed.

"Contactor K1 removed"; "Mains contactor at X5 removed":
start DC bus dynamic brake discharge

"U_D-Signal":
Signal output at X3
(not for DKC**.3-016)

"Control voltage removed"
DC24V supply at X1

"Bb contact open":
without DC24V at X1 the Bb relay in DKC**.3 is brought into home position (N/O opened).

Note: Removing the DC24V at X1 causes the Bb contact to open, the removal of the U_D signal and the loss of the diagnosis displayed at H1 despite the existing DC bus voltage.

16.8 Directory of Standards and Guidelines

Standards	Edition	Title
		Principles for computers in safety-related systems
prEN 1921	1995	Industrial automation systems - Safety of integrated manufacturing systems - Basic requirements (ISO 11161:1994 modified)
EN 50170/2	1996-12	"General purpose field communication system; English version EN 50170:1996 Volume 2/3 PROFIBUS"
EN 50254	1998-12	High efficiency communication subsystem for small data packages
EN 60204-1	1997-12	Safety of machinery - Electrical equipment of machines - Part 1: General requirements (IEC 60204-1:1997 + Corrigendum 1998)
EN 60529 + EN 60259/A1	1991-10 2000-02	Degrees of protection provided by enclosures (IP code) (IEC 60529:1989 + A1:1999)
EN 292-1	1991	"Safety of machinery; basic concepts, general principles for design; part 1: basic terminology, methodology"
prEN 292-1	2000-04	"Safety of machinery; basic concepts, general principles for design; part 1: basic terminology, methodology (Identical with ISO/DIS 12000-1); Revision of EN 292-1:1991"
EN 292-2 EN 292-2/A1	1991-09 1995-03	"Safety of machinery - Basic concepts, general principles for design - Part 2: Technical principles and specifications; German version EN 292-2:1991 + A1:1995"
prEN 292-2	2000-04	"Safety of machinery - Basic concepts, general principles for design - Part 2: Technical principles and specifications (Identical with ISO/DIS 12000-2); Revision of EN 292-2:1991 and EN 292-2:1991/A1:1995"
EN 61941	1998-08	Electrical equipment of industrial machines - Serial data link for real-time communication between controls and drives (IEC 61491:1995, modified)
EN 954-1	1996-12	Safety of machinery - Safety-related parts of control systems - Part 1: General principles for design
EN 1037	1995-12	Safety of machinery - Prevention of unexpected start-up
EN 12415	1996-05	Machine tools - Safety - Small numerically controlled turning machines and turning centres
EN 12417	1996-05	Machine tools - Safety - Machining centres
EN 775	1992-10	"Manipulating industrial robots; safety (ISO 10218:1992, modified)"
ISO 11898	1993-11	"Road vehicles - Interchange of digital information - Controller area network (CAN) for high-speed communication; identical with ISO 11898:1993 (Status as of 1994)"
EN 50178	1997-10	Electronic equipment for use in power installations
EN 61800-3	1996-10	Adjustable speed electrical power drive systems - Part 3: EMC product standard including specific test methods (IEC 61800-3:1996)
73/23/EEC	1973-02-19	"Council Directive of 19 February 1973 on the harmonization of the laws of Member States relating to electrical equipment designed for use within certain voltage limits
93/68/EEC	1993-07-22	93/68/EEC: COUNCIL DIRECTIVE 93/68/EEC of 22 July 1993 amending Directives 87/404/EEC (simple pressure vessels), 88/378/EEC (safety of toys), 89/106/EEC (construction products), 89/336/EEC (electromagnetic compatibility), 89/392/EEC (machinery), 89/686/EEC (personal protective equipment), 90/384/EEC (non-automatic weighing instruments), 90/385/EEC (active implantable medicinal devices), 90/396/EEC (appliances burning gaseous fuels), 91/263/EEC (telecommunications terminal equipment), 92/42/EEC (new hot-water boilers fired with liquid or gaseous fuels) and 73/23/EEC (electrical equipment designed for use within certain voltage limits)
89/336/EEC	1989-05-03	COUNCIL DIRECTIVE of 3 May 1989 on the approximation of the laws of the Member States relating to electromagnetic compatibility (89/336/EEC)

Fig. 16-40: Standards and Guidelines

Norm	Ausgabe	Titel
DIN V VDE 0801	1990-01	Grundsätze für Rechner in Systemen mit Sicherheitsaufgaben
E DIN EN 1921	1995-10	Industrielle Automatisierungssysteme - Sicherheit von integrierten Fertigungssystemen - Grundlegende Anforderungen (ISO 11161:1994, modifiziert)
DIN EN 50170/2	1997-07	"Universelles Feldkommunikationssystem; Englische Fassung EN 50170:1996 Band 2/3 PROFIBUS"
DIN EN 50254	1999-07	Kommunikationssystem mit hoher Effizienz für kleine Datenpakete
DIN EN 60204-1, VDE 0113 Teil 1	1998-11	Sicherheit von Maschinen - Elektrische Ausrüstung von Maschinen - Teil 1: Allgemeine Anforderungen (IEC 60204-1:1997 + Corrigendum 1998)
DIN EN 60529, VDE 0470 Teil 1	2000-09	Schutzarten durch Gehäuse (IP-Code) (IEC 60529:1989 + A1:1999)
DIN EN 292-1	1991-11	"Sicherheit von Maschinen; Grundbegriffe, allgemeine Gestaltungsleitsätze; Teil 1: Grundsätzliche Terminologie, Methodik"
E DIN EN 291-1	2000-06	"Sicherheit von Maschinen; Grundbegriffe, allgemeine Gestaltungsleitsätze; Teil 1: Grundsätzliche Terminologie, Methodik (Identisch mit ISO/DIS 12100-1); Überarbeitung von EN 292-1:1991"
DIN EN 292-2	1995-06	"Sicherheit von Maschinen - Grundbegriffe, allgemeine Gestaltungsleitsätze - Teil 2: Technische Leitsätze und Spezifikationen; Deutsche Fassung EN 292-2:1991 + A1:1995"
E DIN EN 292-2	2000-06	"Sicherheit von Maschinen - Grundbegriffe, allgemeine Gestaltungsleitsätze - Teil 2: Technische Leitsätze und Spezifikationen (Identisch mit ISO/DIS 12100-2); Überarbeitung von EN 292-2:1991 + EN 292-2:1991/A1:1995"
DIN EN 61941	1999-11	Elektrische Ausrüstung von Industriemaschinen - Serielle Datenverbindung für Echtzeit-Kommunikation zwischen Steuerungen und Antrieben (IEC 61491:1995, modifiziert)
DIN EN 954-1	1997-03	Sicherheit von Maschinen - Sicherheitsbezogene Teile von Steuerungen - Teil 1: Allgemeine Gestaltungsleitsätze
DIN EN 1037	1996-04	Sicherheit von Maschinen - Vermeidung von unerwartetem Anlauf
DIN EN 12415	1996-08	Werkzeugmaschinen - Sicherheit - Kleine numerisch gesteuerte Drehmaschinen und Drehzentren
DIN EN 12417	1996-08	Werkzeugmaschinen - Sicherheit - Bearbeitungszentren
DIN EN 775	1993-08	"Industrieroboter; Sicherheit (ISO 10218:1992, modifiziert)"
DIN ISO 11898	1995-08	Straßenfahrzeuge - Austausch digitaler Informationen - Steuergerätenetz (CAN) für schnellen Datenaustausch (ISO 11898:1993) (Stand 1994)
DIN EN 50178 VDE 0160	1998-04	Ausrüstung von Starkstromanlagen mit elektronischen Betriebsmitteln
DIN EN 61800-3	1997-08	Drehzahlveränderbare elektrische Antriebe - Teil 3: EMV-Produktnorm einschließlich spezieller Prüfverfahren (IEC 61800-3:1996)
73/23/EWG	1973-02-19	Richtlinie des Rates vom 19. Februar 1973 zur Angleichung der Rechtsvorschriften der Mitgliedstaaten betreffend elektrische Betriebsmittel zur Verwendung innerhalb bestimmter Spannungsgrenzen
93/68/EWG	1993-07-22	Richtlinie 93/68/EWG des Rates vom 22. Juli 1993 zur Änderung der Richtlinien 87/404/EWG (einfache Druckbehälter), 88/378/EWG (Sicherheit von Spielzeug), 89/106/EWG (Bauprodukte), 89/336/EWG (elektromagnetische Verträglichkeit), 89/392/EWG (Maschinen), 89/686/EWG (persönliche Schutzausrüstungen), 90/384/EWG (nichtselbsttätige Waagen), 90/385/EWG (aktive implantierbare medizinische Geräte), 90/396/EWG (Gasverbrauchseinrichtungen), 91/263/EWG (Telekommunikationsendeinrichtungen), 92/42/EWG (mit flüssigen oder gasförmigen Brennstoffen beschickte neue Warmwasserheizkessel) und 73/23/EWG (elektrische Betriebsmittel zur Verwendung innerhalb bestimmter Spannungsgrenzen)
89/336/EWG	1989-05-03	Richtlinie des Rates vom 3. Mai 1989 zur Angleichung der Rechtsvorschriften der Mitgliedstaaten über die elektromagnetische Verträglichkeit

Fig. 16-41: Normen und Richtlinien

17 Index

2

- 24V control voltage supply - BZM 6-9
- 24V control voltage supply (+24V and 0V) 4-45
- 24V control voltage supply (DKC**.3-016) 5-19

A

- Absolute Encoder Emulation (SSI format) 4-84
- Additional Accessories 13-4
- Address switch (DKC**.3-016) 5-44
- Allowed DC bus continuous power (DKC**.3-016) 5-12
- Allowed DC bus continuous power in single-phase mode with 50 Hz 4-36
- Allowed DC bus continuous power in single-phase mode with 50 Hz (DKC**.3-016) 5-13
- Allowed DC bus continuous power in single-phase mode with 60 Hz (DKC**.3-016) 5-14
- Allowed DC bus continuous power without auxiliary components 4-28
- Allowed DC bus Peak Power 4-27
- Allowed DC bus Peak Power (DKC**.3-016) 5-12
- Allowed encoder cable lengths 4-79
- Ambient and operating conditions 4-5, 6-3, 7-3
- Amplitude of the BZM control voltage charging current at startup, to selecting power source 6-4
- An Overview of Communications Interfaces 1-3
- An Overview of Drive Controllers and Auxiliary Components 1-3
- An Overview of Individual Components of the ECODRIVE03 Family 1-2
- Analog inputs 4-57
- Analog inputs 1 and 2 4-57
- Analog Interface 4-121
- Analog outputs 1 and 2 4-58
- Appropriate use
 - Introduction 2-1
- Appropriate uses
 - Uses 2-2
- Arranging ECODRIVE03 Components in the Control Cabinet 12-12
- Autotransformer 10-1
- Auxiliary capacitance module CZM01.3 7-1
- Avoiding condensation 12-15
- Avoiding dripping or spraying water 12-14

B

- Basic connection of holding brake 4-72
- Basic connection of holding brake (DKC**.3-016) 5-40
- Basic connection of motor power 4-72
- Basic connection of motor power (DKC**.3-016) 5-40
- Basic connection of motor temperature monitoring 4-72
- Basic connection of motor temperature monitoring (DKC**.3-016) 5-40
- Bb 4-48, 5-22, 11-2
 - BZM 6-10
 - DKC 4-48
 - DKC**.3-016 5-22
- Block diagram of the DKC**.3-016-7-FW power section 5-5
- Block diagram of the DKC**.3-040-7-FW power section 4-10
- Block diagram of the DKC**.3-100-7-FW power section 4-11
- Block diagram of the DKC**.3-200-7-FW power section 4-12
- BR+, BR- 4-69
- Bus Connector 4-111
- BZM 6-1

C

- Cable
 - Replacing 15-4

- Cable length
 - X9 4-81
- Calculating the available continuous braking resistor and DC bus power 16-5
- Cams 4-54
- CANopen Interface 4-117, 4-118
- CE label 4-39, 6-5, 7-4
- CE label (DKC**.3-016) 5-15
- Central supply 4-19, 4-25
- Choke GLD 12 8-1
- Clear error
 - BZM 6-16
 - DKC 4-54
- Command Value Box 16-28
- Commissioning Aids 13-4
- Communications Interfaces 1-3
- Complete Terminal Diagram - BZM 6-7
- computing charging current inrush 11-8
- Computing phase current on the mains 11-7
- Connecting the Measuring System 4-61
- Connecting the Measuring System (DKC**.3-016) 5-31
- Connecting the measuring systems 1-4
- Connecting the Systems to the Encoder Inputs 1-4
- Connection Choke (DR+, DR-) 4-93
- Connection cross section
 - X15 4-97
 - X210 4-121
- Connection cross section
 - BZM - X1 6-9
 - BZM - X2 6-11
 - BZM - X5 6-17
 - CZM - X5 7-6
 - CZM - XE1 7-8
 - X1 4-45, 5-19
 - X10 4-86
 - X11 4-88
 - X12 4-93
 - X2 4-49
 - X3 4-53
 - X30 4-108
 - X4 4-59
 - X40 4-114
 - X41 4-114
 - X5 4-62
 - X50 4-117
 - X6 4-67
 - X60 4-119
 - X8 4-75
 - X9 4-81
- Connection diagram for DeviceNet-Interface 4-120
- Connection diagram for InterBus Interface 4-115
- Connection diagram for Parallel Interface 4-98
- Connection diagram for parallel interface 2 4-122
- Connection diagram for Profibus-DP Interface 4-109
- Connection diagram for SERCOS interface 4-104, 4-125
- Connection encoder - emulation 4-81
- Connection length
 - X10 4-87
- Connections on top of the drive controller 4-42
- Connections on top of the drive controller (DKC**.3-016) 5-17
- Constructing the Control Cabinet 12-1
- Continuous braking resistor and DC bus power
 - calculation 16-5
- Control Circuits with E-Stop 11-3
- Control Circuits with internal DC bus dynamic brake (ZKS) 11-5
- Control connection
 - detail view X1, X3, X10, XS2 and XS3 with cable shield connection 16-13
 - Detail view X4, X8 and XS2 with cable shield connection 16-18
 - Detail view X9, X10, X11 and XS3 with cable shield connection 16-18
 - view of DKC02.3-016 16-10
 - View of DKC02.3-040-7 16-15
 - view of DKC03.3-016 16-11

- View of DKC03.3-040-7 16-16
- view of DKC21.3-016 16-12
- View of DKC21.3-040-7 16-17
- View with contact protection 16-14
- Control inputs for jog mode (Jog+, Jog-) 4-101
- Control inputs for stepper motor mode 4-102
- Control voltage connection (DKC**.3-016) 5-6
- Control voltage connection for DKC 4-13
- Control voltage connections 4-45, 6-9
- Control voltage connections (DKC**.3-016) 5-19
- Controlling with the stepper motor interface 4-103
- C-UL listing 4-39
- C-UL listing (DKC**.3-016) 5-15
- CZM01.3 (DKC**.3-016) 16-4

D

- Data rate 4-105
- DC bus connection 4-62
 - BZM 6-18
- DC bus continuous power in single-phase mode with 60 Hz 4-37
- DC bus Peak Power 4-27
- DC bus Peak Power (DKC**.3-016) 5-12
- DC24V NTM power supplies 9-1
- DC24V voltage supply for BZM 6-4
- Designations
 - drive controller and connector 4-40
 - drive controller and connector (DKC**.3-016) 5-16
- DeviceNet Interface 4-119
- DeviceNet-Interface 4-120
- Diagnostic display (DKC**.3-016) 5-44
- Diagnostic display for CANopen 4-118
- Diagnostic display for DeviceNet Interface 4-120
- Diagnostic display for InterBus Interface 4-116
- Diagnostic display for parallel interface 2 4-122
- Diagnostic display for Profibus-DP Interface 4-110
- Diagnostic LEDs and Reset Probe - BZM 6-21
- Differential signals 4-103
- Digital I/Os (DKC**.3-016) 5-25
- Digital outputs (ready and warning message) (DKC**.3-016) 5-27
- Digital outputs (ready, warning and UD-message) 4-55
- Dimension sheets auxiliary capacitance module CZM01.3 7-2
- Dimensions
 - BZM01.3 6-1
 - CZM01.3 7-2
 - DKC 4-1, 5-1
 - GLD 12 8-1
- Dimensions (DKC**.3-016) 5-1
- Directory of Standards and Guidelines 16-33
- Distances 12-6
- DKC 02.3-***-7-FW 4-104
- DKC 03.3-***-7-FW 4-108
- DKC 04.3-***-7-FW 4-114
- DKC 05.3-***-7-FW 4-117
- DKC 06.3-***-7-FW 4-119
- DKC 22.3-***-7-FW 4-125
- DKC**.3-016 (Technical Data) 5-1
- DKC**.3-040-7 in "Central supply" 4-28
- DKC**.3-040-7 in "Group supply with DC bus connection" 4-28
- DKC**.3-040-7 in "Group supply without DC bus connection" 4-28
- DKC**.3-040-7 in "Single source supply" 4-28
- DKC**.3-040-7 with CZM01.3 in "Central supply" 4-31
- DKC**.3-040-7 with CZM01.3 in "Group supply with DC bus connection" 4-31
- DKC**.3-040-7 with CZM01.3 in "Group supply without DC bus connection" 4-31
- DKC**.3-040-7 with CZM01.3 in "Single source supply" 4-31
- DKC**.3-100-7 in "Central supply" 4-29
- DKC**.3-100-7 in "Group supply with DC bus connection" 4-29
- DKC**.3-100-7 in "Group supply without DC bus connection" 4-29
- DKC**.3-100-7 in "Single source supply" 4-29
- DKC**.3-100-7 with CZM01.3 in "Central supply" 4-32

DKC**.3-100-7 with CZM01.3 in "Group supply without DC bus connection" 4-32
 DKC**.3-100-7 with CZM01.3 in "Single source supply" 4-32
 DKC**.3-200-7 in "Central supply" 4-30
 DKC**.3-200-7 in "Group supply with DC bus connection" 4-30
 DKC**.3-200-7 in "Group supply without DC bus connection" 4-30
 DKC**.3-200-7 in "Single source supply" 4-30
 DKC**.3-200-7 with CZM01.3 and filter choke GLD12 in "Central supply" 4-35
 DKC**.3-200-7 with CZM01.3 and filter choke GLD12 in "Group supply with DC bus connection" 4-35
 DKC**.3-200-7 with CZM01.3 and filter choke GLD12 in "Group supply without DC bus connection" 4-35
 DKC**.3-200-7 with CZM01.3 and filter choke GLD12 in "Single source supply" 4-35
 DKC**.3-200-7 with CZM01.3 in "Central supply" 4-33
 DKC**.3-200-7 with CZM01.3 in "Group supply with DC bus connection" 4-33
 DKC**.3-200-7 with CZM01.3 in "Group supply without DC bus connection" 4-33
 DKC**.3-200-7 with CZM01.3 in "Single source supply" 4-33
 DR+, DR- 4-93
 Drive address (DKC**.3-016) 5-44
 Drive controller
 Replacing: 15-3
 Drive controller and connector
 designations 4-40
 designations (DKC**.3-016) 5-16
 Drive enable 4-47, 5-21
 Drive halt 4-47, 5-21
 Drive halt (AH) and Drive enable (RF) 4-47
 Drive halt (AH) and Drive enable (RF) (DKC**.3-016) 5-21
 Drive package ECODRIVE03 1-1
 DST transformers 10-1

E

Earth-leakage circuit breaker 11-2
 ECODRIVE03 Auxiliary Bleeder Module BZM01.3 6-1
 EcoX expansion interface (DKC**.3-016) 5-41
 Electric Data of the Individual DKC**.3 Components 4-6
 Electric Data of the Individual DKC**.3-016 Components 5-4
 Electrical Connections – dependent on the drive controller type 4-97
 Electrical connections - DKC**.3-016 5-16
 Electrical connections - independent of the drive controller Type 4-40
 Electrical data of auxiliary component BZM01.3 6-3
 EMC in the Control Cabinet 12-17
 Encoder - emulation 4-81
 Encoder 1 4-59
 Encoder 1 (DKC**.3-016) 5-29
 Encoder 2 4-75
 Energy circuit DKC**.3 using "central supply" as an example 4-26
 E-Stop 4-54, 11-3
 Exit and entrance of cooling air 12-6
 Expansion interface 4-86
 Extent of Delivery 13-2

F

Fault report 15-6
 Fiber optic cables 4-106
 Firmware (DKC**.3-016-7-FW)
 Replacing 15-9
 Firmware (DKC**.3-040/100/200-7-FW)
 Replacing 15-7
 Firmware Module
 Replacing 15-8
 Front view
 CZM01.3 7-5
 DKC 4-40
 DKC**.3-016 5-16
 Front view BZM01.3 6-6, 6-20
 Fuse protector Q2 9-1
 Fuses 11-7

G

G1_8V/Sin 4-60
 G1_8V/Sin (DKC**.3-016) 5-30
 G1Cos+ (S4), G1Cos- (S2) 4-60
 G1Cos+ (S4), G1Cos- (S2) (DKC**.3-016) 5-30
 G1Sample 4-59, 5-29
 G1SCLK 4-59, 5-29
 G1SDA0, G1SDAI 4-59, 5-29
 G1Sin+ (S3), G1Sin- (S1) 4-60
 G1Sin+ (S3), G1Sin- (S1) (DKC**.3-016) 5-30
 G2_5V 4-77
 G2_5VSen 4-77
 G2Cos+, G2Cos- 4-77
 G2EnDat+, G2EnDat- 4-75
 G2EnDatClk+, G2EnDatClk- 4-75
 G2Ref+, G2Ref- 4-77
 G2Sin+, G2Sin- 4-76
 Grounded power supply lines 10-1
 Grounded three-phase current networks 11-1
 Group supply 4-19
 Group supply (DKC**.3-016) 5-11
 Group supply with DC bus connection 4-24
 Group supply without DC bus connection 4-23

H

H1 (DKC**.3-016) 5-44
 Holding brake (BR+, BR-) 4-69
 Holding brake (DKC**.3-016) 5-38
 Holding brakes 4-67
 Holding brakes (DKC**.3-016) 5-36
 Homing switch 4-54

I

Identifying the Components 14-1
 Inappropriate use 2-2
 Consequences, Discharge of liability 2-1
 Incremental and Absolute Encoder Emulation (SSI format) 4-81
 Incremental encoder emulation 4-82
 Introduction to the system 1-1
 Insulation Monitoring 4-46
 Insulation Monitoring (DKC**.3-016) 5-19
 InterBus Interface 4-114

J

Jog+, Jog- 4-101

L

Limit+, Limit- 4-54
 Line filter 9-1, 11-1
 Load 6-14
 LWL-Handling 4-106

M

Mains connections
 BZM 6-19
 DKC 4-66
 DKC**.3-016 5-35
 Power section (DKC**.3-016), data 5-4
 Power section, data 4-6
 View of DKC**.3-016-7 16-19
 View with contact protection DKC**.3-100-7 16-22
 View X5, X6, X12, XE1, XE2 and XS1 with cable shield connection on DKC**.3-200-7 16-25

- View X5, X6, XE1, XE2 and XS1 with cable shield connection on DKC**.3-100-7 16-23
- Mains Connections (DKC**.3-016) 5-32
- Mains Contactor 11-7
- Mains supply options 4-19
- Mains supply options (DKC**.3-016) 5-10
- Mass 4-15
 - BZM01.3 6-2
 - CZM01.3 7-3
 - DKC 4-15
- Mass (DKC**.3-016) 5-2
- Materials 4-15
- Materials (DKC**.3-016) 5-2
- Materials used 4-15, 7-3
 - BZM01.3 6-2
- Measuring devices 16-27
- Measuring Systems Connections 4-80
- Module widths 12-11
- Motor
 - Replacing 15-4
- Motor connection 1-4, 4-64
 - BZM 6-18
- Motor connection (DKC**.3-016) 5-33
- Motor Connections (DKC**.3-016) 5-32
- Motor holding brake 4-71
- Motor holding brake (DKC**.3-016) 5-40
- Motor power cables 4-64
- Motor power cables (DKC**.3-016) 5-33
- Motor temperature monitoring 4-67
- Motor temperature monitoring (DKC**.3-016) 5-36
- Motor temperature monitoring (TM+, TM) 4-68
- Motor temperature monitoring (TM+, TM) (DKC**.3-016) 5-37
- Mounting Accessories 13-4
- mounting plate 12-6
- Mounting Position 12-6
- Mounting the cooling unit onto top 16-9
- Multiple Row Construction of the Control Cabinet 12-12

N

- Number of ECODRIVE03 Units and Auxiliary Components on one DC bus 4-20

O

- Optional Choke Connection for DKC**.3-200-7 4-93
- Ordering 13-4
- Output current characteristic curves for servo applications (acceleration times < 400 ms) 4-16
- Output current characteristic curves for servo applications (acceleration times < 400 ms) (DKC**.3-016) 5-8
- Overvoltage 11-1

P

- Packaging 13-1
- Papers 13-2
- Parallel interface 4-98
- Parallel Interface 4-97
- Parallel Interface 2 4-121
- Parameter Module
 - Replacing 15-7
- PE connection 4-95, 6-20
 - CZM 7-8
- PE connection (DKC**.3-016) 5-42
- Position of switch 4-105
- Positioning block mode 4-101
- Power connection
 - View with contact protection DKC**.3-040-7 16-20
 - View with contact protection DKC**.3-200-7 16-24
- Power dissipation 12-1
- Power-dependent arrangement 12-13

- Probes 4-54
- Profibus-DP Interface 4-108
- Programming module 4-73
- Programming Module
 - Replacing 15-8
- Protective conductor connection
 - mains 4-95
 - mains (DKC**.3-016) 5-42
 - motor 4-95
 - motor (DKC**.3-016) 5-42
- Protective conductor connection for mains 6-20

Q

- Q1 Fuse and K1 Contactor 11-12

R

- Ready 4-56
- Ready - BZM 6-15
- Ready to operate Bb 11-2
- Ready to operate contact
 - BZM 6-10
 - DKC 4-48
 - DKC**.3-016 5-22
- Recommendations on constructing the control cabinet 16-7
- Recommended Off Sequence 16-31
- Recommended Switching On Sequence 16-29
- Replacement Parts 13-4
- Replacing
 - Cable 15-4
 - Drive controller 15-3
 - Firmware (DKC**.3-016-7-FW) 15-9
 - Firmware (DKC**.3-040/100/200-7-FW) 15-7
 - Firmware Module 15-8
 - Motor 15-4
 - Parameter Module 15-7
 - Programming Module 15-8
- Replacing the Motor 15-4
- Resettaster (DKC**.3-016) 5-44
- RS232 interface 4-50
- RS232 interface (DKC**.3-016) 5-24
- RS485 - Connector 16-26
- RS485 interface 4-51
 - connection 4-52

S

- S1 (DKC**.3-016) 5-44
- S2 (DKC**.3-016) 5-44
- S2, S3 (DKC**.3-016) 5-44
- S3 (DKC**.3-016) 5-44
- Safety distance
 - BZM**.3-01-7 12-10
 - DKC**.3-040-7 12-8
 - DKC**.3-100-7 12-8
 - DKC**.3-200-7 12-9
- Safety Instructions for Electric Drives and Controls 3-1
- Selection
 - DST 10-1
- Selection criteria for supply options 4-21
- SERCOS interface 4-104
- SERCOS Interface 4-104
- SERCOS interface 2 4-125
- Serial bus 4-51
- Serial Interface 4-49
- Serial Interface (DKC**.3-016) 5-23
- Setting the Drive Address 4-74
- Setting the Drive Address (DKC**.3-016) 5-45
- Shield Connections 4-96

- Shield Connections (DKC**.3-016) 5-43
- Shielding
 - X9 4-81
- Short circuit protection
 - X2 4-49
- Signal allocation to the actual position value 4-61
- Signal allocation to the actual position value (DKC**.3-016) 5-31
- Signal filtering 4-83
- Signal Sequence DKC**.3 16-29
- Single source supply 4-19, 4-22
- Single source supply (DKC**.3-016) 5-10
- Sizing
 - CZM (DKC**.3-016) 16-4
- Slave 4-113
- SM1+, SM1-, SM2+, SM2 4-100
- State of Delivery 13-1
- Stepper motor 4-100
 - cycle frequency 4-101
 - Differential input circuit 4-100
 - inputs 4-100
- Stepper motor mode 4-102
- Storable energy 7-4
- Storable energy in the bus 4-17
- Storable energy in the bus (DKC**.3-016) 5-9
- Switch S2, S3 4-74
- Switch S2, S3 (DKC**.3-016) 5-45
- Switch S20
 - data rate, transmitter power 4-105
- Switch S22 4-125

T

- Technical data
 - BZM01.3 6-1
 - CZM01.3 7-2
 - GLD 12 8-1
- Technical Data
 - DKC 4-7
 - DKC**.3-016-7 5-5
- Technical Data (DKC**.3-016) 5-1
- Technical data Motor holding brake 4-71
- Technical description of connector
 - BZM - X1 6-9
 - BZM - X5 6-17
 - BZM - XE1 6-20
 - CZM - X5 7-6
 - CZM - XE1 7-8
 - X1 4-45
 - X10 4-86
 - X11 4-88
 - X12 4-93
 - X15 4-97
 - X2 4-49
 - X210 4-121
 - X3 4-53
 - X30 4-108
 - X4 4-59
 - X40 4-114
 - X41 4-114
 - X5 4-62
 - X50 4-117
 - X6 4-67
 - X60 4-119
 - X8 4-75
 - X9 4-81
 - XE1, XE2 4-95
- Technical description of connector - BZM 6-11
- Terminal diagram
 - BZM01.3 6-7
- Terminating resistor 4-111
- Tests 6-5, 7-4

Tightening torque
 X12 4-93
 X5 4-62, 6-17, 7-6
 XE1 4-95, 6-20, 7-8
 XE2 4-95
 TM+, TM- 4-68
 TM+, TM- (DKC**.3-016) 5-37
 Total connection diagram
 DKC 4-44
 Total connection diagram (DKC**.3-016) 5-18
 Transmitter power 4-105, 4-106
 Type code
 BZM 1-6
 CZM 1-6
 DKC 1-5
 DST 10-4
 NTM 9-4
 Type plates
 Basic Unit 14-2
 DKC, BZM, CZM, NTM, NFD/NFE 14-2
 DST/DLT 14-3
 FWA 14-2
 Overview 14-1
 Programming Module 14-3
 Typical application areas 1-1

U

U_D power supply 4-88, 4-91
 U_D-message 4-56
 Ungrounded power supply lines 10-1
 Ungrounded three-phase networks 11-1
 Unit Types Available 13-4
 Use *See* appropriate use *and see* inappropriate use
 Using Cooling Units in the Control Cabinet 12-14

V

Voltage connection for brakes 4-70
 Voltage connection for brakes (DKC**.3-016) 5-39
 Voltage connection for holding brake 4-15
 Voltage connection for holding brake (DKC**.3-016) 5-7

W

Wall cooling unit in the control cabinet door 16-8
 Warning - BZM 6-15
 Warnings 4-56
 What is needed to prepare to start-up 16-27
 Wire routing 16-10
 Control connection DKC**.3-040/100/200 16-13
 DKC**.3-016 control connections 16-10
 Power connection 16-19
 Wire routing in the Control Cabinet 12-17
 Wiring 16-10

X

X1, Connections for Control voltage 4-45
 X1, Connections for Control voltage (DKC**.3-016) 5-19
 X10, EcoX Expansion interface 4-86
 X10, EcoX Expansion interface (DKC**.3-016) 5-41
 X11, DC bus dynamic brake (ZKS), UD power supply 4-88
 X12, Optional Choke Connection for DKC**.3-200-7 4-93
 X2, Serial Interface 4-49
 X2, Serial Interface (DKC**.3-016) 5-23
 X3, Digital and analog I/Os 4-53
 X3, Digital I/Os (DKC**.3-016) 5-25
 X4, Encoder 1 4-59
 X4, Encoder 1 (DKC**.3-016) 5-29

X5, DC bus, Motor and Mains Connections 4-62
X5, Motor and Mains Connections (DKC**.3-016) 5-32
X6, Motor temperature monitoring 4-67
X6, Motor temperature monitoring (DKC**.3-016) 5-36
X7, Connection for Programming module 4-73
X8, Encoder 2 4-75
X9, Incremental and Absolute Encoder Emulation (SSI format) 4-81
XE1 4-95
XE1 (DKC**.3-016) 5-42
XE1, XE2 (DKC**.3-016) 5-42
XE2 4-95
XE2 (DKC**.3-016) 5-42
XS1 6-20
XS1 (DKC**.3-016) 5-43
XS1, Shield Connection 4-96
XS2 6-20
XS2 (DKC**.3-016) 5-43
XS2, Shield Connection 4-96
XS3 (DKC**.3-016) 5-43
XS3, Shield Connection 4-96

Z

ZKS connection 11-5
ZKS control input - BZM 6-13
ZKS control supply 4-89
ZKS control supply- BZM 6-12
ZKS setup 11-5

18 Service & Support

18.1 Helpdesk

Unser Kundendienst-Helpdesk im Hauptwerk Lohr am Main steht Ihnen mit Rat und Tat zur Seite. Sie erreichen uns

- telefonisch: **+49 (0) 9352 40 50 60**
über Service Call Entry Center Mo-Fr 07:00-18:00
- per Fax: **+49 (0) 9352 40 49 41**
- per e-Mail: **service@indramat.de**

Our service helpdesk at our headquarters in Lohr am Main, Germany can assist you in all kinds of inquiries. Contact us

- by phone: **+49 (0) 9352 40 50 60**
via Service Call Entry Center
Mo-Fr 7:00 am - 6:00 pm
- by fax: **+49 (0) 9352 40 49 41**
- by e-mail: **service@indramat.de**

18.2 Service-Hotline

Außerhalb der Helpdesk-Zeiten ist der Service direkt ansprechbar unter

oder **+49 (0) 171 333 88 26**
+49 (0) 172 660 04 06

After helpdesk hours, contact our service department directly at

or **+49 (0) 171 333 88 26**
+49 (0) 172 660 04 06

18.3 Internet

Unter www.indramat.de finden Sie ergänzende Hinweise zu Service, Reparatur und Training sowie die **aktuellen** Adressen *) unserer auf den folgenden Seiten aufgeführten Vertriebs- und Servicebüros.

- Verkaufsniederlassungen
- Niederlassungen mit Kundendienst

Außerhalb Deutschlands nehmen Sie bitte zuerst Kontakt mit unserem für Sie nächstgelegenen Ansprechpartner auf.

*) <http://www.indramat.de/de/kontakt/adressen>
Die Angaben in der vorliegenden Dokumentation können seit Drucklegung überholt sein.

At www.indramat.de you may find additional notes about service, repairs and training in the Internet, as well as the **actual** addresses *) of our sales- and service facilities figuring on the following pages.

- sales agencies
- offices providing service

Please contact our sales / service office in your area first.

*) <http://www.indramat.de/en/kontakt/adressen>
Data in the present documentation may have become obsolete since printing.

18.4 Vor der Kontaktaufnahme... - Before contacting us...

Wir können Ihnen schnell und effizient helfen wenn Sie folgende Informationen bereithalten:

1. detaillierte Beschreibung der Störung und der Umstände.
2. Angaben auf dem Typenschild der betreffenden Produkte, insbesondere Typenschlüssel und Seriennummern.
3. Tel./Faxnummern und e-Mail-Adresse, unter denen Sie für Rückfragen zu erreichen sind.

For quick and efficient help, please have the following information ready:

1. Detailed description of the failure and circumstances.
2. Information on the type plate of the affected products, especially type codes and serial numbers.
3. Your phone/fax numbers and e-mail address, so we can contact you in case of questions.

18.5 Kundenbetreuungsstellen - Sales & Service Facilities

Deutschland – Germany

vom Ausland: (0) nach Landeskennziffer weglassen!
from abroad: don't dial (0) after country code!

Vertriebsgebiet Mitte Germany Centre Rexroth Indramat GmbH Bgm.-Dr.-Nebel-Str. 2 / Postf. 1357 97816 Lohr am Main / 97803 Lohr Kompetenz-Zentrum Europa Tel.: +49 (0)9352 40-0 Fax: +49 (0)9352 40-4885	SERVICE CALL ENTRY CENTER MO – FR von 07:00 - 18:00 Uhr from 7 am – 6 pm Tel. +49 (0) 9352 40 50 60 service@indramat.de	SERVICE HOTLINE MO – FR von 17:00 - 07:00 Uhr from 5 pm - 7 am + SA / SO Tel.: +49 (0)172 660 04 06 oder / or Tel.: +49 (0)171 333 88 26	SERVICE ERSATZTEILE / SPARES verlängerte Ansprechzeit - extended office time - ♦ nur an Werktagen - only on working days - ♦ von 07:00 - 18:00 Uhr - from 7 am - 6 pm - Tel. +49 (0) 9352 40 42 22
Vertriebsgebiet Süd Germany South Rexroth Indramat GmbH Landshuter Allee 8-10 80637 München Tel.: +49 (0)89 127 14-0 Fax: +49 (0)89 127 14-490	Gebiet Südwest Germany South-West Bosch Rexroth AG Vertrieb Deutschland – VD-BI Geschäftsbereich Rexroth Indramat Regionalzentrum Südwest Ringstrasse 70 / Postfach 1144 70736 Fellbach / 70701 Fellbach Tel.: +49 (0)711 57 61-100 Fax: +49 (0)711 57 61-125	Vertriebsgebiet Ost Germany East Bosch Rexroth AG Beckerstraße 31 09120 Chemnitz Tel.: +49 (0)371 35 55-0 Fax: +49 (0)371 35 55-333	Vertriebsgebiet Ost Germany East Bosch Rexroth AG Regionalzentrum Ost Walter-Köhn-Str. 4d 04356 Leipzig Tel.: +49 (0)341 25 61-0 Fax: +49 (0)341 25 61-111
Vertriebsgebiet West Germany West Bosch Rexroth AG Vertrieb Deutschland Regionalzentrum West Borsigstrasse 15 40880 Ratingen Tel.: +49 (0)2102 409-0 Fax: +49 (0)2102 409-406	Vertriebsgebiet Mitte Germany Centre Bosch Rexroth AG Regionalzentrum Mitte Waldecker Straße 13 64546 Mörfelden-Walldorf Tel.: +49 (0) 61 05 702-3 Fax: +49 (0) 61 05 702-444	Vertriebsgebiet Nord Germany North Bosch Rexroth AG Walsroder Str. 93 30853 Langenhagen Tel.: +49 (0) 511 72 66 57-0 Service: +49 (0) 511 72 66 57-256 Fax: +49 (0) 511 72 66 57-93 Service: +49 (0) 511 72 66 57-95	Vertriebsgebiet Nord Germany North Bosch Rexroth AG Kieler Straße 212 22525 Hamburg Tel.: +49 (0) 40 81 955 966 Fax: +49 (0) 40 85 418 978

Europa (West) - Europe (West)

vom Ausland: (0) nach Landeskennziffer weglassen, **Italien:** 0 nach Landeskennziffer mitwählen
from abroad: don't dial (0) after country code, **Italy:** dial 0 after country code

<p>Austria - Österreich</p> <p>Bosch Rexroth GmbH Bereich Indramat Stachegasse 13 1120 Wien</p> <p>Tel.: +43 (0)1 985 25 40 Fax: +43 (0)1 985 25 40-93</p>	<p>Austria – Österreich</p> <p>Bosch Rexroth G.m.b.H. Gesch.ber. Rexroth Indramat Industriepark 18 4061 Pasching</p> <p>Tel.: +43 (0)7221 605-0 Fax: +43 (0)7221 605-21</p>	<p>Belgium - Belgien</p> <p>Bosch Rexroth AG Electric Drives & Controls Industrielaan 8 1740 Ternat</p> <p>Tel.: +32 (0)2 5830719 - service: +32 (0)2 5830717 Fax: +32 (0)2 5830731 indramat@boschrexroth.be</p>	<p>Denmark - Dänemark</p> <p>BEC A/S Zinkvej 6 8900 Randers</p> <p>Tel.: +45 (0)87 11 90 60 Fax: +45 (0)87 11 90 61</p>
<p>Great Britain – Großbritannien</p> <p>Bosch Rexroth Ltd. Rexroth Indramat Division Broadway Lane, South Cerney Cirencester, Glos GL7 5UH</p> <p>Tel.: +44 (0)1285 863000 Fax: +44 (0)1285 863030 sales@boschrexroth.co.uk service@boschrexroth.co.uk</p>	<p>Finland - Finnland</p> <p>Bosch Rexroth Oy Rexroth Indramat division Ansatie 6 017 40 Vantaa</p> <p>Tel.: +358 (0)9 84 91-11 Fax: +358 (0)9 84 91-13 60</p>	<p>France - Frankreich</p> <p>Bosch Rexroth S.A. Division Rexroth Indramat Avenue de la Trentaine BP. 74 77503 Chelles Cedex</p> <p>Tel.: +33 (0)164 72-70 00 Fax: +33 (0)164 72-63 00 Hotline: +33 (0)608 33 43 28</p>	<p>France - Frankreich</p> <p>Bosch Rexroth S.A. Division Rexroth Indramat 1270, Avenue de Lardenne 31100 Toulouse</p> <p>Tel.: +33 (0)5 61 49 95 19 Fax: +33 (0)5 61 31 00 41</p>
<p>France - Frankreich</p> <p>Bosch Rexroth S.A. Division Rexroth Indramat 91, Bd. Irène Joliot-Curie 69634 Vénissieux – Cedex</p> <p>Tel.: +33 (0)4 78 78 53 65 Fax: +33 (0)4 78 78 53 62</p>	<p>Italy - Italien</p> <p>Bosch Rexroth S.p.A. Via G. Di Vittoria, 1 20063 Cernusco S/N.MI</p> <p>Tel.: +39 02 2 365 270 Fax: +39 02 700 408 252378</p>	<p>Italy - Italien</p> <p>Bosch Rexroth S.p.A. Via Paolo Veronesi, 250 10148 Torino</p> <p>Tel.: +39 011 224 88 11 Fax: +39 011 224 88 30</p>	<p>Italy - Italien</p> <p>Bosch Rexroth S.p.A. Via del Progresso, 16 (Zona Ind.) 35020 Padova</p> <p>Tel.: +39 049 8 70 13 70 Fax: +39 049 8 70 13 77</p>
<p>Italy - Italien</p> <p>Bosch Rexroth S.p.A. Via Mascia, 1 80053 Castellamare di Stabia NA</p> <p>Tel.: +39 081 8 71 57 00 Fax: +39 081 8 71 68 85</p>	<p>Italy - Italien</p> <p>Bosch Rexroth S.p.A. Viale Oriani, 38/A 40137 Bologna</p> <p>Tel.: +39 051 34 14 14 Fax: +39 051 34 14 22</p>	<p>Netherlands – Niederlande/Holland</p> <p>Bosch Rexroth B.V. Kruisbroeksestraat 1 (P.O. Box 32) 5281 RV Boxtel</p> <p>Tel.: +31 (0)411 65 19 51 Fax: +31 (0)411 65 14 83 indramat@hydraudyne.nl</p>	<p>Netherlands - Niederlande/Holland</p> <p>Bosch Rexroth Services B.V. Kruisbroeksestraat 1 (P.O. Box 32) 5281 RV Boxtel</p> <p>Tel.: +31 (0)411 65 19 51 Fax: +31 (0)411 67 78 14</p>
<p>Norway - Norwegen</p> <p>Bosch Rexroth AS Rexroth Indramat Division Berghagan 1 or: Box 3007 1405 Ski-Langhus 1402 Ski</p> <p>Tel.: +47 (0)64 86 41 00 Fax: +47 (0)64 86 90 62 jul.ruud@rexroth.no</p>	<p>Spain - Spanien</p> <p>Bosch Rexroth S.A. Divisiòn Rexroth Indramat Centro Industrial Santiga Obradors s/n 08130 Santa Perpetua de Mogoda Barcelona</p> <p>Tel.: +34 9 37 47 94 00 Fax: +34 9 37 47 94 01</p>	<p>Spain – Spanien</p> <p>Goimendi S.A. Divisiòn Rexroth Indramat Parque Empresarial Zuatzu C/ Francisco Grandmontagne no.2 20018 San Sebastian</p> <p>Tel.: +34 9 43 31 84 21 - service: +34 9 43 31 84 56 Fax: +34 9 43 31 84 27 - service: +34 9 43 31 84 60 sat.indramat@goimendi.es</p>	<p>Sweden - Schweden</p> <p>Rexroth Mecman Svenska AB Rexroth Indramat Division - Varuvägen 7 (Service: Konsumentvägen 4, Älfsjö) 125 81 Stockholm</p> <p>Tel.: +46 (0)8 727 92 00 Fax: +46 (0)8 647 32 77</p>
<p>Sweden - Schweden</p> <p>Rexroth Mecman Svenska AB Indramat Support Ekvåndan 7 254 67 Helsingborg</p> <p>Tel.: +46 (0) 42 38 88 -50 Fax: +46 (0) 42 38 88 -74</p>	<p>Switzerland West - Schweiz West</p> <p>Bosch Rexroth Suisse SA Département Rexroth Indramat Rue du village 1 1020 Renens</p> <p>Tel.: +41 (0)21 632 84 20 Fax: +41 (0)21 632 84 21</p>	<p>Switzerland East - Schweiz Ost</p> <p>Bosch Rexroth Schweiz AG Geschäftsbereich Indramat Hemrietstrasse 2 8863 Buttikon</p> <p>Tel. +41 (0) 55 46 46 111 Fax +41 (0) 55 46 46 222</p>	

Europa (Ost) - Europe (East)

vom Ausland: (0) nach Landeskennziffer weglassen
from abroad: don't dial (0) after country code

Czech Republic - Tschechien	Czech Republic - Tschechien	Hungary - Ungarn	Poland – Polen
Bosch -Rexroth, spol.s.r.o. Hviezdoslavova 5 627 00 Brno Tel.: +420 (0)5 48 126 358 Fax: +420 (0)5 48 126 112	DEL a.s. Strojirenská 38 591 01 Zdar nad Sázavou Tel.: +420 616 64 3144 Fax: +420 616 216 57	Bosch Rexroth Kft. Angol utca 34 1149 Budapest Tel.: +36 (1) 364 00 02 Fax: +36 (1) 383 19 80	Bosch Rexroth Sp.zo.o. ul. Staszica 1 05-800 Pruszków Tel.: +48 22 738 18 00 – service: +48 22 738 18 46 Fax: +48 22 758 87 35 – service: +48 22 738 18 42
Poland – Polen	Rumania - Rumänien	Russia - Russland	Russia - Russland
Bosch Rexroth Sp.zo.o. Biuro Poznan ul. Dabrowskiego 81/85 60-529 Poznan Tel.: +48 061 847 64 62 /-63 Fax: +48 061 847 64 02	Bosch Rexroth Sp.zo.o. Str. Drobety nr. 4-10, app. 14 70258 Bucuresti, Sector 2 Tel.: +40 (0)1 210 48 25 +40 (0)1 210 29 50 Fax: +40 (0)1 210 29 52	Bosch Rexroth Wjatskaja ul. 27/15 125015 Moskau Tel.: +7-095-785 74 78 +7-095 785 74 79 Fax: +7 095 785 74 77 laura.kanina@boschrexroth.ru	ELMIS 10, Internationalnaya Str. 246640 Gomel, Belarus Tel.: +375/ 232 53 42 70 +375/ 232 53 21 69 Fax: +375/ 232 53 37 69 elmis_ltd@yahoo.com
Turkey - Türkei	Slowenia - Slowenien		
Bosch Rexroth Otomasyon San & Tic. A.S. Fevzi Cakmak Cad No. 3 34630 Sefaköy Istanbul Tel.: +90 212 541 60 70 Fax: +90 212 599 34 07	DOMEL Otoki 21 64 228 Zelezniki Tel.: +386 5 5117 152 Fax: +386 5 5117 225 brane.ozebek@domel.si		

Africa, Asia, Australia – incl. Pacific Rim

vom Ausland: (0) nach Landeskennziffer weglassen!
from abroad: don't dial (0) after country code!

<p>Australia - Australien</p> <p>AIMS - Australian Industrial Machinery Services Pty. Ltd. Unit 3/45 Home ST Campbellfield , VIC 3061 Melbourne</p> <p>Tel.: +61 (0) 393 590 228 Fax: +61 (0) 393 590 286 Hotline: +61 (0) 419 369 195 terryobrien@aimservices.com.au</p>	<p>Australia - Australien</p> <p>Bosch Rexroth Pty. Ltd. No. 7, Endeavour Way Braeside Victoria, 31 95 Melbourne</p> <p>Tel.: +61 (0)3 95 80 39 33 Fax: +61 (0)3 95 80 17 33 mel@rexroth.com.au</p>	<p>China</p> <p>Shanghai Bosch Rexroth Hydraulics & Automation Ltd. Wai Gao Qiao Free Trade Zone No.122, Fu Te Dong Yi Road Shanghai 200131 - P.R.China</p> <p>Tel.: +86 21 58 66 30 30 Fax: +86 21 58 66 55 23 roger.shi_sh@boschrexroth.com.cn</p>	<p>China</p> <p>Bosch Rexroth (China) Ltd. 15/F China World Trade Center 1, Jianguomenwai Avenue Beijing 100004, P.R.China</p> <p>Tel.: +86 10 65 05 03 80 Fax: +86 10 65 05 03 79</p>
<p>China</p> <p>Bosch Rexroth (China) Ltd. A-5F., 123 Lian Shan Street Sha He Kou District Dalian 116 023, P.R.China</p> <p>Tel.: +86 411 46 78 930 Fax: +86 411 46 78 932</p>	<p>China</p> <p>Bosch Rexroth (Changzhou) Co.Ltd. Guangzhou Repres. Office Room 1014-1016, Metro Plaza, Tian He District, 183 Tian He Bei Rd Guangzhou 510075, P.R.China</p> <p>Tel.: +86 20 8755-0030 Fax: +86 20 8755-0011 +86 20 8755-2387</p>	<p>Hongkong</p> <p>Bosch Rexroth (China) Ltd. 6th Floor, Yeung Yiu Chung No.6 Ind Bldg. 19 Cheung Shun Street Cheung Sha Wan, Kowloon, Hongkong</p> <p>Tel.: +852 22 62 51 00 Fax: +852 27 41 33 44 alexis.siu@boschrexroth.com.hk</p>	<p>India - Indien</p> <p>Bosch Rexroth (India) Ltd. Rexroth Indramat Division Plot. A-58, TTC Industrial Area Thane Turbhe Midc Road Mahape Village Navi Mumbai - 400 701</p> <p>Tel.: +91 (0)22 7 61 46 22 Fax: +91 (0)22 7 68 15 31</p>
<p>India - Indien</p> <p>Bosch Rexroth (India) Ltd. Rexroth Indramat Division Plot. 96, Phase III Peenya Industrial Area Bangalore - 560058</p> <p>Tel.: +91 (0)80 8 39 73 74 Fax: +91 (0)80 8 39 43 45 rexbang@bgl.vsnl.net.in</p>	<p>Indonesia - Indonesien</p> <p>PT. Rexroth Wijayakusuma Building # 202, Cilandak Commercial Estate Jl. Cilandak KKO, Jakarta 12560</p> <p>Tel.: +62 21 7891169 (5 lines) Fax: +62 21 7891170 - 71</p>	<p>Japan</p> <p>Bosch Rexroth Automation Corp. Service Center Japan Yutakagaoka 1810, Meito-ku, NAGOYA 465-0035, Japan</p> <p>Tel.: +81 (0)52 777 88 41 +81 (0)52 777 88 53 +81 (0)52 777 88 79 Fax: +81 (0)52 777 89 01</p>	<p>Japan</p> <p>Bosch Rexroth Automation Corp. Rexroth Indramat Division 1F, I.R. Building Nakamachidai 4-26-44, Tsuzuki-ku YOKOHAMA 224-0041, Japan</p> <p>Tel.: +81 (0)45 942 72 10 Fax: +81 (0)45 942 03 41</p>
<p>Korea</p> <p>Bosch Rexroth-Korea Ltd. 1515-14 Dadae-Dong, Saha-Ku Rexroth Indramat Division Pusan Metropolitan City, 604-050 Republic of South Korea</p> <p>Tel.: +82 (0)51 26 00 741 Fax: +82 (0)51 26 00 747 gyhan@rexrothkorea.co.kr</p>	<p>Malaysia</p> <p>Bosch Rexroth Sdn.Bhd. 11, Jalan U8/82 Seksyen U8 40150 Shah Alam Selangor, Malaysia</p> <p>Tel.: +60 (0) 3 78 44 80 00 Fax: +60 (0) 3 78 45 48 00 hockhwa@hotmail.com rexroth1@tm.net.my</p>	<p>Singapore - Singapur</p> <p>Bosch Rexroth SDN BHD. No.11, Jalan Astaka U8/82 Seksyen U8 40150 Shah Alam Selangor Darul Ehsan</p> <p>Tel.: +65 (0) 3 7844 8000 Fax: +65 (0) 3 7845 4800 kenton.peh@boschrexroth.com.sg</p>	<p>South Africa - Südafrika</p> <p>TECTRA Automation (Pty) Ltd. 71 Watt Street, Meadowdale Edenvale 1609</p> <p>Tel.: +27 (0)11 971 94 00 Fax: +27 (0)11 971 94 40 Hotline: +27 (0)82 903 29 23 georgv@tectra.co.za</p>
<p>Taiwan</p> <p>Rexroth Uchida Co., Ltd. No.17, Lane 136, Cheng Bei 1 Rd., Yung Kang, Tainan Hsien Taiwan, R.O.C.</p> <p>Tel.: +886 (0)6 25 36 565 Fax: +886 (0)6 25 34 754 indramat@mail.net.tw</p>	<p>Thailand</p> <p>NC Advance Technology Co. Ltd. 59/76 Moo 9 Ramintra road 34 Tharang, Bangkokhen, Bangkok 10230</p> <p>Tel.: +66 2 943 70 62 +66 2 943 71 21 Fax: +66 2 509 23 62 sonkawin@hotmail.com</p>		

Nordamerika – North America

USA Hauptniederlassung - Headquarters Bosch Rexroth Corporation Rexroth Indramat Division 5150 Prairie Stone Parkway Hoffman Estates, IL 60192-3707 Tel.: +1 847 6 45 36 00 Fax: +1 847 6 45 62 01 servicebrc@boschrexroth-us.com repairbrc@boschrexroth-us.com	USA Central Region - Mitte Bosch Rexroth Corporation Rexroth Indramat Division Central Region Technical Center 1701 Harmon Road Auburn Hills, MI 48326 Tel.: +1 248 3 93 33 30 Fax: +1 248 3 93 29 06	USA Southeast Region - Südwest Bosch Rexroth Corporation Rexroth Indramat Division Southeastern Technical Center 3625 Swiftwater Park Drive Suwanee, Georgia 30124 Tel.: +1 770 9 32 32 00 Fax: +1 770 9 32 19 03	USA SERVICE-HOTLINE - 7 days x 24hrs - +1-800-860-1055
USA East Region –Ost Bosch Rexroth Corporation Rexroth Indramat Division Charlotte Regional Sales Office 14001 South Lakes Drive Charlotte, North Carolina 28273 Tel.: +1 704 5 83 97 62 +1 704 5 83 14 86	USA Northeast Region – Nordost Bosch Rexroth Corporation Rexroth Indramat Division Northeastern Technical Center 99 Rainbow Road East Granby, Connecticut 06026 Tel.: +1 860 8 44 83 77 Fax: +1 860 8 44 85 95	USA West Region – West Bosch Rexroth Corporation 7901 Stoneridge Drive, Suite 220 Pleasant Hill, California 94588 Tel.: +1 925 227 10 84 Fax: +1 925 227 10 81	
Canada East - Kanada Ost Bosch Rexroth Canada Corporation Burlington Division 3426 Mainway Drive Burlington, Ontario Canada L7M 1A8 Tel.: +1 905 335 55 11 Fax: +1 905 335-41 84 michael.moro@boschrexroth.ca	Canada West - Kanada West Bosch Rexroth Canada Corporation 5345 Goring St. Burnaby, British Columbia Canada V7J 1R1 Tel.: +1 604 205-5777 Fax: +1 604 205-6944 david.gunby@boschrexroth.ca	Mexico Bosch Rexroth S.A. de C.V. Calle Neptuno 72 Unidad Ind. Vallejo 07700 Mexico, D.F. Tel.: +52 5 754 17 11 +52 5 754 36 84 +52 5 754 12 60 Fax: +52 5 754 50 73 +52 5 752 59 43	Mexico Bosch Rexroth S.A. de C.V. Calle Argentina No 3913 Fracc. las Torres 64930 Monterey, N.L. Tel.: +52 8 333 88 34...36 +52 8 349 80 91...93 Fax: +52 8 346 78 71 mario.quiroga@boschrexroth.com.mx

Südamerika – South America

Argentina - Argentinien Bosch Rexroth S.A.I.C. "The Drive & Control Company" Acassusso 48 41/47 1605 Munro Prov. Buenos Aires Tel.: +54 (0)11 4756 01 40 Fax: +54 (0)11 4756 01 36 victor.jabif@boschrexroth.com.ar	Argentina - Argentinien NAKASE Servicio Tecnico CNC Calle 49, No. 5764/66 1653 Villa Balester Prov. - Buenos Aires Tel.: +54 (0) 11 4768 36 43 Fax: +54 (0) 11 4768 24 13 nakase@usa.net nakase@nakase.com gerencia@nakase.com (Service)	Brazil - Brasilien Bosch Rexroth Ltda. Av. Tégula, 888 Ponte Alta, Atibaia SP CEP 12942-440 Tel.: +55 (0)11 4414 56 92 +55 (0)11 4414 56 84 Fax sales: +55 (0)11 4414 57 07 Fax serv.: +55 (0)11 4414 56 86 alexandre.wittwer@rexroth.com.br	Brazil - Brasilien Bosch Rexroth Ltda. R. Dr.Humberto Pinheiro Vieira, 100 Distrito Industrial [Caixa Postal 1273] 89220-390 Joinville - SC Tel./Fax: +55 (0)47 473 58 33 Mobil: +55 (0)47 9974 6645 prochnow@zaz.com.br
Columbia - Kolumbien Refflutec de Colombia Ltda. Calle 37 No. 22-31 Santafé de Bogotá, D.C. Colombia Tel.: +57 1 368 82 67 +57 1 368 02 59 Fax: +57 1 268 97 37 refflutec@neutel.com.co			



Printed in Germany